

# CDN

## Coupling / Decoupling Network

IEC / EN 61000-4-6

NAMUR NE 21

- Coupling / Decoupling networks for the following frequencies:  
**150 kHz – 230 MHz:**  
Norm IEC / EN 61000-4-6
- Coupling / Decoupling networks for the following frequencies:  
**10 kHz – 230 MHz:**  
Norm IEC / EN 61000-4-6  
NAMUR NE 21



**Coupling networks for different applications.**  
**Special versions on request!**

### Overview

Coupling / decoupling networks (**CDN's**) are used for immunity tests to conducted disturbances induced by radio frequency fields according to IEC / EN 61000-4-6 and other.

A number of different types are available for different applications.

We also produce special models on customer request!

### Key Facts

Field of application	Examples	Types
Unscreened supply lines (mains)	AC grid, direct current in industrial plants, ground connection	<b>CDN-M</b>
Unscreened unbalanced interconnection lines	Audio cable SPS lines	<b>CDN-AF</b>
Unscreened balanced interconnection lines	Communication lines	<b>CDN-T</b> <b>CDN-RJ</b>
BUS-lines	CAN BUS	<b>CDN-CAN</b>
Shielded connecting cables	HDMI, coaxial cable, cable for LAN- and USB connections	<b>CDN-S</b> <b>CDN-RJ45-S</b> <b>CDN-USB</b> <b>CDN-HDMI</b> <b>CDN-Firewire</b>

Detailed description by type number – refer to the following pages



# CDN

## Coupling / Decoupling Network

### CDN-AF

- Coupling / decoupling of interference signals on unshielded, unbalanced lines

Illu.: CDN-AF8 +  
AF8 EUT side

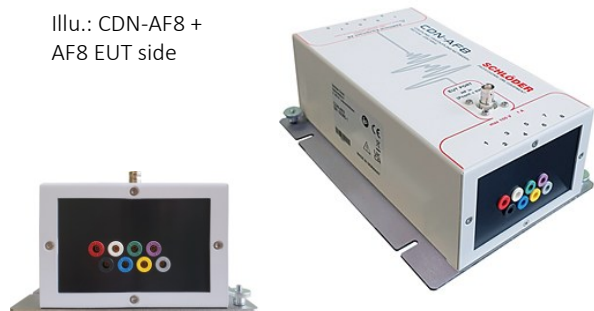

### Technical data (depending on model, see page 3)

Article	CDN-AF2/ AF3/ AF4/5/AF6/AF8	CDN-AF2-10k/ AF3-10k/ AF5-10k
<b>RF In</b>		
Frequency range (RF In)	150 kHz - 230 MHz	10 kHz - 230 MHz
Power Rating (RF In)	6 W (100 % ED)	6 W (100 % ED)
Decoupling attenuation (RF In – AE)	> 20 dB (150 kHz – 230 MHz) > 40 dB (1 MHz – 100 MHz)	> 20 dB (150 kHz – 230 MHz) > 40 dB (1 MHz – 100 MHz)
Insertion loss (RF In – EUT)	10 dB ± 1 dB (150 kHz – 80 MHz) 10 dB + 3 dB (150 kHz – 230 MHz)	10 dB ± 1 dB (150 kHz – 80 MHz) 10 dB + 3 dB (150 kHz – 230 MHz)
Connector	N	N
<b>EUT / AE</b>		
Maximum input voltage	100 VAC / 150 VDC	100 VAC / 150 VDC
Current rating (AE – EUT)	5 A	5 A
Insertion loss (AE – EUT)	< 1 dB (DC – 100 kHz)	< 1 dB (DC – 100 kHz)
Connectors	2 mm safety socket	2 mm safety socket
<b>Mechanical data</b>		
Dimensions (W x H x D)	160 x 82 x 240 mm	160 x 82 x 240 mm

### Circuit diagram

#### Circuit diagram CDN-AF2

(Principle valid for CDN-AF2, AF3, AF4 and AF5).

For CDN-AF6, AF7, AF8, AF9, AF10 and AF12, capacitors C2 are eliminated.

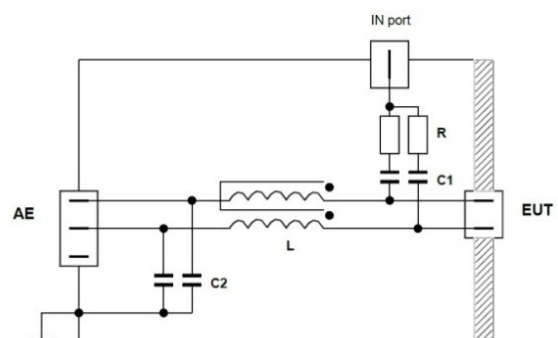

# CDN

## Coupling / Decoupling Network

Models	Current rating AE – EUT (A)	Input voltage		Frequency range RF In				Case size		Connectors
		AC (V)	DC (V)	10 kHz – 80 MHz	10 kHz – 230 MHz	150 kHz – 80 MHz	150 kHz – 230 MHz	160 x 82 x 240 mm A	160 x 102 x 240 mm B	
<b>Article CDN-XX</b>										2 mm safety sockets
AF2	5	100	150				x	x		x
AF2-10k	5	100	150		x			x		x
AF3	5	100	150				x	x		x
AF3-10k	5	100	150		x			x		x
AF4	5	100	150				x	x		x
AF4-10k	5	100	150		x			x		x
AF5	5	100	150				x	x		x
AF5-10k	5	100	150		x			x		x
AF6	5	100	150				x	x		x
AF8	5	100	150				x	x		x

### Calibration adaptor for CDN-AF2 - 5

For the CDN-AF2 - 5 types, the 150 Ohm termination (AE side) is required by the standard, but the calibration values for these CDN types are almost independent of the load.

This is due to the fact that these types have capacitors to ground at the AE terminal, which create an RF short circuit. This means that the 150 Ohm load at the accessory equipment (AE) connection could also be dispensed with for the CDN-AF 2-5.

### Calibration adaptor – Order number

AF-type	Article
AF2	CDG A 4102
AF2-10k	CDG A 4102
AF3	CDG A 4133
AF3-10k	CDG A 4133
AF4	CDG A 4108
AF4-10k	CDG A 4108

AF-type	Article
CDN-AF5	CDG A 4114
CDN-AF5-10k	CDG A 4114
CDN-AF6	CDG A 4134
CDN-AF8	CDG A 4109
Mounting plate with 50/150 Ohm adaptor	CDG A 4100



# CDN

## Coupling / Decoupling Network

### CDN-M

- Coupling / decoupling for unshielded power supply cables
- Nominal voltage up to 1000 V
- Rated current up to 125 A

Illu.: CDN-M5 +  
M5 EUT side



Technical data			
Article	CDN-M1*/-M2/-M3/ -M4/-M5/-M2+3 32A	CDN-M1/-M2/-M3/-M4/ -M5/-M2+3-10k 32A	CDN-M2 /-M3-/ -M4-/-M5 125A
<b>RF In</b>			
Frequency range (RF In)	150 kHz – 230 MHz	10 kHz – 230 MHz	150 kHz – 80 MHz
Power rating (RF In)	6 W (100 % ED)	6 W (100 % ED)	6 W (100 % ED)
Decoupling attenuation (RF In – AE)	> 30 dB (150 kHz – 80 MHz) > 20 dB (80 MHz – 230 MHz)	> 30 dB (150 kHz – 80 MHz) > 15 dB (80 MHz – 230 MHz)	> 30 dB (150 kHz – 80 MHz)
Insertion loss (RF In – EUT)	10 dB +/-1 dB (150 kHz – 80 MHz) 10 dB + 5 dB (80 MHz – 230 MHz)	10 dB +/-1 dB (150 kHz – 80 MHz) 10 dB + 5 dB (80 MHz – 230 MHz)	10 dB +/-1 dB (150 kHz – 80 MHz)
Connector	N	N	N
<b>EUT / AE</b>			
Max input range AC (L-PE)	500 V	500 V	1000 V
Max. input voltage DC	1000 V	1000 V	1000 V
Max. input voltage	500 V	500 V	1000 V
Current rating (AE – EUT)	32 A / 125 A; (M1 / M2+3 I <sub>PE</sub> <0.5 A)		
Insertion loss (AE – EUT)	< 1 dB (DC – 100 kHz)	< 1 dB (DC – 100 kHz)	< 1 dB (DC – 100 kHz)
Connector	4 mm MC safety sockets	4 mm MC safety sockets	Push-in connection up to 35 mm
<b>Mechanical data</b>			
Dimensions (W x H x D)	160 x 102 x 240 mm	160 x 102 x 240 mm	200 x 122 x 400 mm

\* CDN-L1 in 16A/32A available

### Circuit diagram

#### Circuit diagram CDN-M3

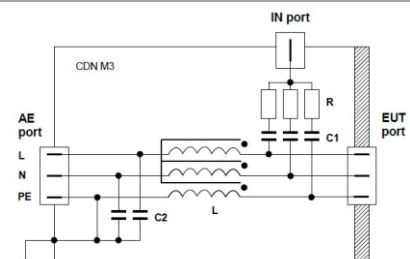

# CDN

## Coupling / Decoupling Network

Models	Current rating AE – EUT (A)	Input voltage		Frequency range RF In				Terminal assignment	Case size		Connector	
		AC (V)	DC (V)	10 kHz – 80 MHz	10 kHz – 230 MHz	150 kHz – 80 MHz	150 kHz – 230 MHz		B 160 x 102 x 240 mm	C 200 x 122 x 400 mm	4 mm MC safety sockets	Phoenix Contact Push-In connection up to 35 mm <sup>2</sup>
Article CDN-XX												
M1	32*	500	1000				x	PE	x		x	
M1-10k	32*	500	1000		x			PE	x		x	
L1	16	500	1000				x	L	x		x	
L1-32A	32	500	1000				x	L	x		x	
M2	32	500	1000				x	L, N	x		x	
M2-10k	32	500	1000		x			L, N	x		x	
M2-125A	125	1000	1000			x		L, N		x		x
M2+3	32	500	1000				x	L, N, PE	x		x	
M2+3-10k	32	500	1000		x			L, N, PE	x		x	
M3	32	500	1000				x	L, N, PE	x		x	
M3-10k	32	500	1000		x			L, N, PE	x		x	
M3-L	32	500	1000			x		3 x L	x		x	
M3-L-10k	32	500	1000		x			3 x L	x		x	
M3-125A	125	1000	1000			x		L, N, PE		x		x
M3-L-125A	125	1000	1000			x		3 x L		x		x
M4	32	500	1000				x	3 x L, PE	x		x	
M4-10k	32	500	1000		x			3 x L, N				
M4-N	32	500	1000				x	3 x L, N	x		x	
M4-125A	125	1000	1000			x		3 x L, PE		x		x
M4-N-125A	125	1000	1000			x		3 x L, N		x		x
M5	32	500	1000				x	3 x L, N, PE	x		x	
M5-10k	32	500	1000		x			3 x L, N, PE	x		x	
M5-125A	125	1000	1000			x		3 x L, N, PE		x		x

\* max. 0.5 A saturation current



Illu.: CDN-M5-125



## CDN

### Coupling / Decoupling Network

#### Calibration adaptor for CDN-M

For CDN-M - types, the 150 Ohm termination (AE side) is required by the standard, but the calibration values for these CDN types are almost independent of the load.

This is due to the fact that M-types have capacitors connected to ground on the AE side, which create an RF short circuit. Therefore, those CDN M do not really require the 150 Ohm load on the AE side.

#### Calibration adaptor – Order number

M-type	Article	M-type	Article
CDN-M1	CDG A 4101	CDN-M4	CDG A 4136
CDN-M1-10k	CDG A 4101	CDN-M4-10k	CDG A 4136
CDN-L1	CDG A 4101	CDN-M4-N	CDG A 4136
CDN-L1-32A	CDG A 4101	CDN-M4-125A	CDG A 4116
CDN-M2	CDG A 4101	CDN-M4-N-125A	CDG A 4116
CDN-M2-10k	CDG A 4101	CDN-M5	CDG A 4128
CDN-M2-125A	CDG A 4116	CDN-M5-10k	CDG A 4128
CDN-M2+3	CDG A 4101	CDN-M5-125A	CDG A 4116
CDN-M2+3-10k	CDG A 4101	Mounting plate with 50/150 Ohm adaptor	CDG A 4100
CDN-M3	CDG A 4101		
CDN-M3-10k	CDG A 4101		
CDN-M3-L	CDG A 4101		
CDN-M3-L-10k	CDG A 4101		
CDN-M3-125A	CDG A 4116		
CDN-M3-L-125A	CDG A 4116		



# CDN

## Coupling / Decoupling Network

### CDN-RJ

- Coupling / decoupling of interference signals on unshielded, balanced lines

Illu.: CDN-RJ45 + RJ45 EUT side



Technical data		
Article	CDN-RJ45	CDN-RJ45-10k
<b>RF In</b>		
Frequency range (RF In)	150 kHz – 230 MHz	10 kHz – 230 MHz
Power rating (RF In)	6 W (continuous)	6 W (continuous)
Decoupling attenuation (RF In – AE)	> 20 dB (150 kHz – 230 MHz)	> 20 dB (150 kHz – 230 MHz)
Insertion loss (RF In – EUT)	10 dB ± 1 dB (150 kHz – 80 MHz) 10 dB + 3 dB (80 MHz – 230 MHz)	10 dB ± 1 dB (150 kHz – 80 MHz) 10 dB + 3 dB (80 MHz – 230 MHz)
Connector	N	N
<b>EUT / AE</b>		
Maximum input voltage	100 VAC / 150 VDC	100 VAC / 150 VDC
Current rating (AE – EUT)	1.5 A	1.5 A
Insertion loss (AE – EUT)	< 1 dB (DC – 10 kHz) < 10 dB (10 MHz – 100 MHz)	< 1 dB (DC – 10 kHz) < 10 dB (10 MHz – 100 MHz)
Data transfer	up to 1 Gbit/s	up to 1 Gbit/s
Connector	RJ45 socket (8-pin)	RJ 45 socket (8-pin)
<b>Mechanical data</b>		
Dimensions (W x H x D)	160 x 82 x 240 mm	160 x 82 x 240 mm

### Circuit diagram

#### Circuit diagram CDN-RJ45

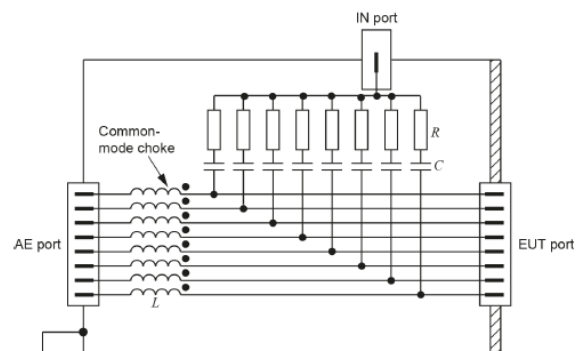

### Calibration adaptor – Order number

RJ-type	Article
RJ45	CDG A 4118
Mounting plate with 50/150 Ohm adaptor	CDG A 4100



# CDN

## Coupling / Decoupling Network

### CDN-T

- Coupling / decoupling of interference signals on unshielded, balanced lines

Illu.: CDN-T2 +  
T2 EUT side



Technical data		
Article	CDN-T2, -T4, -T8	CDN-T2-10k, T4-10k, T8-10k
<b>RF In</b>		
Frequency range (RF In)	150 kHz – 230 MHz	10 kHz – 230 MHz
Power rating (RF In)	6 W (continuous)	6 W (continuous)
Decoupling attenuation (RF In – AE)	> 20 dB (150 kHz – 230 MHz)	> 20 dB (150 kHz – 230 MHz)
Insertion loss (RF In – EUT)	10 dB ± 1 dB (150 kHz – 230 MHz)	10 dB ± 1 dB (150 kHz – 230 MHz)
Connector	N	N
<b>EUT / AE</b>		
Maximum input voltage AC	100 V	100 V
Maximum input voltage DC	150 V	150 V
Current rating (AE – EUT)	0.5 A	0.5 A
Insertion loss (AE – EUT)	< 1 dB (DC – 1 MHz) < 10 dB (1 MHz – 100 MHz)	< 1 dB (DC – 1 MHz) < 10 dB (1 MHz – 100 MHz)
Connector	2 mm safety socket	2 mm safety socket
<b>Mechanical data</b>		
Dimensions (B x H x T)	160 x 82 x 240 mm	160 x 82 x 240 mm

### Circuit diagram

#### Circuit diagram CDN-T2

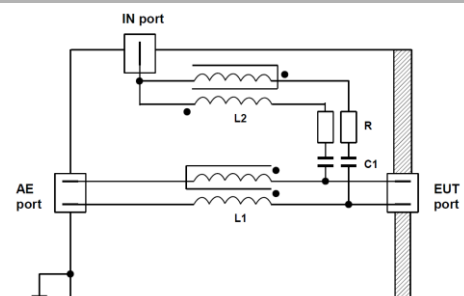

### Calibration adaptor – Order number

T-type	Article
T2 (also T2-10k)	CDG A 4102
T4 (also T4-10k)	CDG A 4108
T8 (also T8-10k)	CDG A 4109
Mounting plate with 50/150 Ohm adaptor	CDG A 4100



# CDN

## Coupling / Decoupling Network

### CDN CAN

- Coupling / decoupling of interference signals on bus lines

Illu.: CAN EUT side  
(Illu. similar)



Technical data		
Article	CDN-CAN-L4	CDN-CAN-L5
<b>RF In</b>		
Frequency range (RF In)	150 kHz - 230 MHz	150 kHz - 230 MHz
Power rating (RF In)	6 W (continuous)	6 W (continuous)
Decoupling attenuation (RF In – AE)	PIN 2+7: > 35 dB (150 kHz – 230 MHz) PIN 3+9: > 35 dB (150 kHz – 200 MHz) > 25 dB (200 MHz – 230 MHz)	PIN 2+7: > 35 dB (150 kHz – 230 MHz) PIN 3+6+9: > 35 dB (150 kHz – 200 MHz) > 25 dB (200 MHz – 230 MHz)
Insertion loss (RF In – EUT)	10 dB ± 1 dB (150 kHz – 230 MHz)	10 dB ± 1 dB (150 kHz – 230 MHz)
Connector	N	N
<b>EUT / AE</b>		
Max. input voltage AC	50 V	50 V
Max. input voltage DC	50 V	50 V
Current rating (AE – EUT)	PIN 2+7 = 0.5 A; PIN 3+9 = 3 A	PIN 2+7 = 0,5 A PIN 3+6+9 = 3 A
Insertion loss (AE – EUT)	PIN 2+7: < 1 dB (DC – 10 MHz) < 10 dB (10 MHz – 500 MHz) PIN 3+9: < 1 dB (DC – 100 kHz)	PIN 2+7: < 1 dB (DC – 10 MHz), < 10 dB (10 MHz – 500 MHz) PIN 3+6+9: < 1 dB (DC – 100 kHz)
Connector	9-pol Sub-D female	9-pol Sub-D female
<b>Mechanical data</b>		
Dimensions (W x H x D)	160 x 82 x 240 mm	160 x 82 x 240 mm

### Circuit diagram

#### Circuit diagram CDN-CAN (L5)

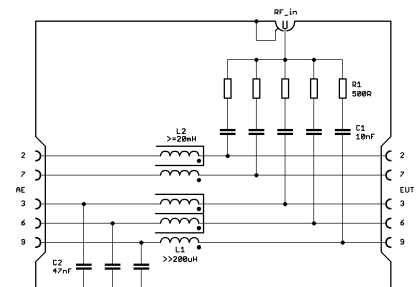

### Calibration adaptor – Order number

CAN-type	Article
CAN-L4   - L5	CDG A 4131
Mounting plate with 50/150 Ohm adaptor	CDG A 4100



# CDN

## Coupling / Decoupling Network

### CDN-S

- Coupling / decoupling of interference signals on shielded cables

**Device for direct coupling available** (without decoupling network), see CDN D 100

### Technical data (additional versions see following page)

Article	CDN-S1	-S1-75*	-S2	-S3	-S4	-S9	-S15	-S25
<b>EUT / AE</b>								
Connector EUT	BNC fem.	BNC fem.	XLR male	5 pin male XLR	8 pin ma. Mini-DIN	9-pol. ma. Sub-D	15 pin ma. Sub-D	25 pin ma. Sub-D
Connector AE	BNC fem.	BNC fem.	XLR fem.	5 pin fem. XLR	8 pin fem. Mini-DIN	9-pol. fem. Sub-D	15 pin fem. Sub-D	25 pin fem. Sub-D
Max. input voltage	150 VAC / 200 VDC							
Current rating (AE – EUT)	1.5 A							
Insertion loss (AE – EUT)	< 1 dB (0 – 10 MHz) < 10 dB (10 MHz – 500 MHz)							
<b>RF In</b>								
Frequency range (RF In)	10 kHz – 230 MHz							
Power rating (RF In)	6 W (continuous)							
Decoupling attenuation (RF In – AE)	> 35 dB (150 kHz – 80 MHz) > 30 dB (80 MHz – 230 MHz)							
Insertion loss (RF In – EUT)	10 dB ± 1 dB (150 kHz – 80 MHz); 10 dB + 3 dB (80 MHz – 230 MHz)							
Connector	N							
<b>Mechanical data</b>								
Dimensions (W x H x D)	160 mm x 82 mm x 240 mm							

\* CDN S1\_75: Special version 75 Ohm

### Circuit diagram

#### Circuit diagram CDN-S1

The interference signal transmitted via a 100 Ω resistor, is coupled to the cable shield.

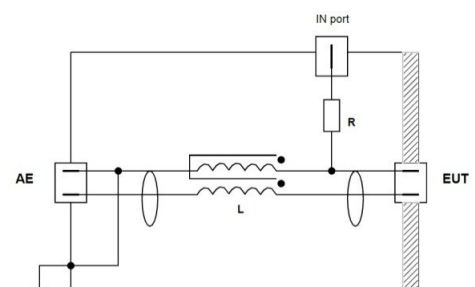

## CDN

### Coupling / Decoupling Network

**Calibration adaptor – Order number (Only needed on EUT-side!)**

<b>S-type</b>	<b>Article</b>
CDN-S1	CDG A 4103
CDN-S1-75 Ohm	CDG A 4103
CDN-S2	CDG A 4104
CDN-S3	CDG A 4124
CDN-S4	CDG A 4130
CDN-S9	CDG A 4105
CDN-S15	CDG A 4113
CDN-S25	CDG A 4106
Mounting plate with 50/150 Ohm adaptor	CDG A 4100



# CDN

## Coupling / Decoupling Network

### CDN-RJ45-S / -HDMI 2.1 / -FireWire

- Coupling / decoupling of interference signals on shielded cables

Illu.: CDN RJ45-S +  
RJ45-S EUT side (Illu. similar)

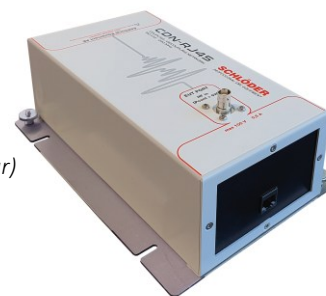

Technical data			
Article	CDN-RJ45-S	CDN-HDMI (HDMI 2.1) *	CDN-FireWire**
<b>RF In</b>			
Frequency range (RF In)	10 kHz – 230 MHz	10 kHz – 230 MHz	10 kHz – 230 MHz
Power rating (RF In)	6 W (continuous)	6 W (continuous)	6 W (continuous)
Decoupling attenuation (RF In – AE)	> 30 dB (150 kHz – 230 MHz)	> 50 dB (150 kHz – 80 MHz) > 25 dB (80 MHz – 230 MHz)	
Insertion loss (RF In – EUT)	10 dB ± 1 dB (150 kHz – 80 MHz) 10 dB + 3 dB (80 MHz – 230 MHz)		
Connector	N	N	N
<b>EUT / AE</b>			
Max. input voltage	100 VAC / 150 VDC	100 VAC / 150 VDC	100 VAC / 150 VDC
Current rating (AE – EUT)	1.0 A	0.5 A	0.5 A
Insertion loss (AE – EUT)	< 0.3 dB (DC – 10 MHz) < 1 dB (10 MHz – 100 MHz) < 3 dB (100 MHz – 500 MHz)	< 1 dB (DC – 10 MHz) < 10 dB (10 MHz – 500 MHz)	
Data rate	up to 10 Gbit/s		
Connectors	shielded RJ45 socket	shielded HDMI sockets	FireWire 6 pin sock.
<b>Mechanical data</b>			
Dimensions (W x H x D)	160 mm x 82 mm x 240 mm		

\*Functions CDN HDMI – next page    \*\*for IEEE 1394 devices

### Circuit diagram

#### Circuit diagram CDN

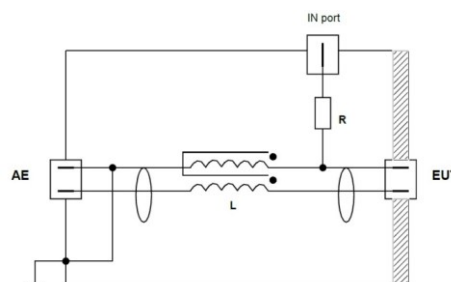

### Calibration adaptor – Order number (Only needed on EUT-side!)

CDN-type	Article
RJ45-S	CDG A 4117
HDMI	CDG A 4123
FireWire	CDG A 4127
Mounting plate with 50/150 Ohm adaptor	CDG A 4100



## CDN

### Coupling / Decoupling Network

Functions for CDN HDMI 2.1		
<b>HDCP</b>	1.0+, HDCP 2.2 from HDMI 2.0	<b>HDCP – High-bandwidth Digital Content Protection</b> <ul style="list-style-type: none"> <li>- HDCP 1.x/2.x is possible from HDMI 1.0 onwards, but has been used more frequently from 1.3/1.4 onwards, especially HDCP 2.2 for 4K content.</li> <li>- HDCP support depends primarily on the HDMI device, not just on the standard.</li> </ul>
<b>HEC</b>	1.4+	<b>HEC – HDMI Ethernet Channel</b> <ul style="list-style-type: none"> <li>- HEC was introduced with HDMI 1.4.</li> <li>- This allows an HDMI cable to also transmit an Ethernet signal.</li> </ul>
<b>ARC</b>	1.4+	<b>ARC – Audio Return Channel</b> <ul style="list-style-type: none"> <li>- ARC was also introduced with HDMI 1.4.</li> <li>- It allows audio to be sent from the TV back to the AV receiver without a separate cable.</li> </ul>
<b>DSC</b>	2.1+	<b>DSC – Display Stream Compression</b> <ul style="list-style-type: none"> <li>- DSC is a compression technology for higher resolutions (e.g., 8K at 60 Hz or 4K at 120 Hz).</li> <li>- DSC is supported from HDMI 2.1 onwards.</li> </ul>



# CDN

## Coupling / Decoupling Network

CDN-  
USB-3.0 / -Z / -Z\_10 / -P / -P\_10

- Coupling / decoupling of interference signals on shielded cables (USB 2.0 compatible)

CDN-USB-3.0 (type A)  
(Illu. similar)



CDN USB-3.0-P (type A)



CDN USB-3.0-Z (type B)

### Technical data

Article	CDN-USB-3.0-Z	CDN-USB-3.0-P
<b>RF In</b>		
Frequency range (RF In)	10 kHz - 230 MHz	10 kHz - 230 MHz
Power rating (RF In)	6 W	6 W
Decoupling attenuation (RF In – AE)	> 50 dB (150 kHz - 80 MHz) > 25 dB (80 MHz - 230 MHz)	
Insertion loss (RF In – EUT)	10 dB ± 1 dB (150 kHz - 80 MHz) 10 dB + 3 dB (80 MHz - 230 MHz)	
Connector	N	N
<b>EUT / AE</b>		
Max. input voltage	100 VAC / 150 VDC	100 VAC / 150 VDC
Current rating (AE – EUT)	0,9 A	0,9 A
Insertion loss (AE – EUT)	< 1 dB (DC - 10 MHz) < 10 dB (10 MHz - 500 MHz)	
Connectors:	EUT: USB-B	EUT: USB-A
USB socket	AE: USB-A	AE: USB-B
<b>Mechanical data</b>		
Dimensions (W x H x D)	160 x 82 x 240 mm	

### Circuit diagram

#### Circuit diagram

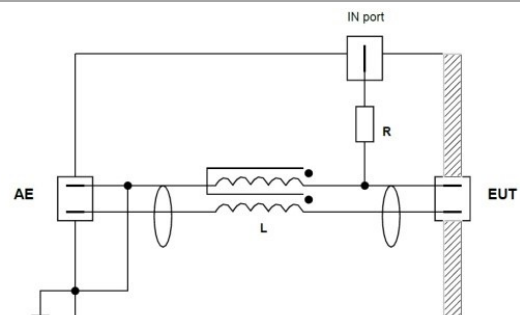

# CDN

## Coupling / Decoupling Network

### CDN- USB Type-C

- Coupling / decoupling of interference signals on shielded cables

Illu.: CDN-USB Type-C +  
USB Type-C – EUT side



### Technical data

Article	CDN-USB Type-C
<b>RF In</b>	
Frequency range (RF In)	10 kHz - 230 MHz
Power rating (RF In)	6 W
Decoupling attenuation (RF In – AE)	> 50 dB (150 kHz - 80 MHz) > 25 dB (80 MHz - 230 MHz)
Insertion loss (RF In – EUT)	10 dB ± 1 dB (150 kHz - 80 MHz) 10 dB + 3 dB (80 MHz - 230 MHz)
Connector	N
<b>EUT / AE</b>	
Max. input voltage	100 VAC / 150 VDC
Current rating (AE – EUT)	0.9 A
Insertion loss (AE – EUT)	< 1 dB (DC - 10 MHz) < 10 dB (10 MHz - 500 MHz)
Connectors: USB socket	EUT: USB-C socket AE: USB-C socket
<b>Mechanical data</b>	
Dimensions (W x H x D)	160 x 82 x 240 mm

### Circuit diagram

#### Circuit diagram

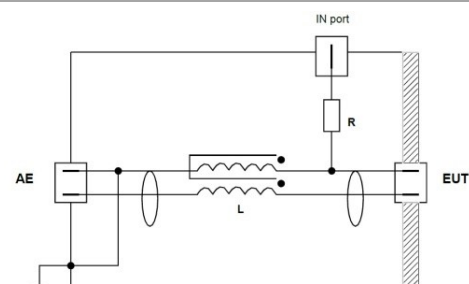

# CDN

## Coupling / Decoupling Network

Calibration adaptor – Order number (Only needed on EUT-side!)

CDN-type	Article
CDN-USB-3.0-P	CDG A 4122
CDN-USB-3.0-Z	CDG A 4121
CDN-USB Type-C	CDG A 4146
Mounting plate with 50/150 Ohm adaptor	CDG A 4100

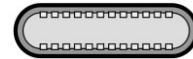
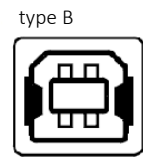
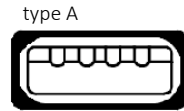

type C



# CDN

## Coupling / Decoupling Network

### CDN D 100

- Device for direct coupling  
100  $\Omega$  Connection for RF disturbance  
variables 10 kHz - 230 MHz

Including  
calibration adaptor

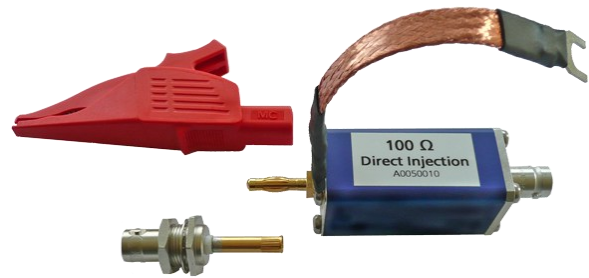

### Overview

The interference signal coming from the test generator is fed into shielded and coaxial cables via a 100  $\Omega$  resistor (even if the shield is ungrounded or grounded at one end only).

A decoupling device must be inserted between the additional/auxiliary equipment and the feed-in point as close as possible to the feed-in point.

To increase decoupling and stabilize the circuit, a ground connection must be made from the shield of the input of the device used for direct coupling to the reference ground plane. This connection is made on the side of the supply unit where the auxiliary device is connected.

### Technical data

Article	<b>CDN D 100</b>
<b>RF In</b>	
Frequency range (RF In)	10 kHz 230 MHz
Power rating (RF In)	6 W (continuous)
Common mode impedance (IN/OUT)	100 $\Omega$
<b>EUT / AE</b>	
Connector In	BNC
Connector Out	Alligator clip; max. cable diameter 30 mm



# CDN

## Coupling / Decoupling Network

### Calibration CDN D 100

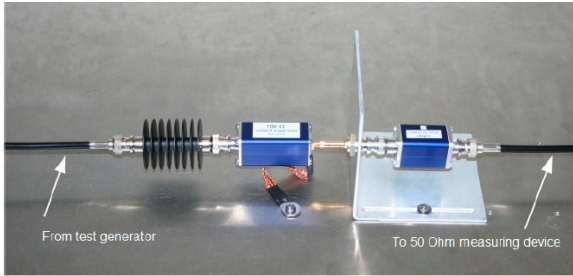

Setting of the output level

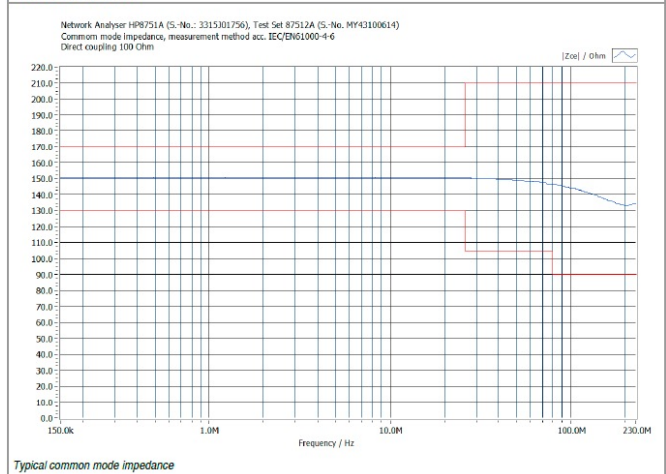

### Technical drawing: Dimensions

- Case size A: 160 x 82 x 240 mm
- Case size B: 160 x 102 x 240 mm
- Case size C: 200 x 122 x 400 mm

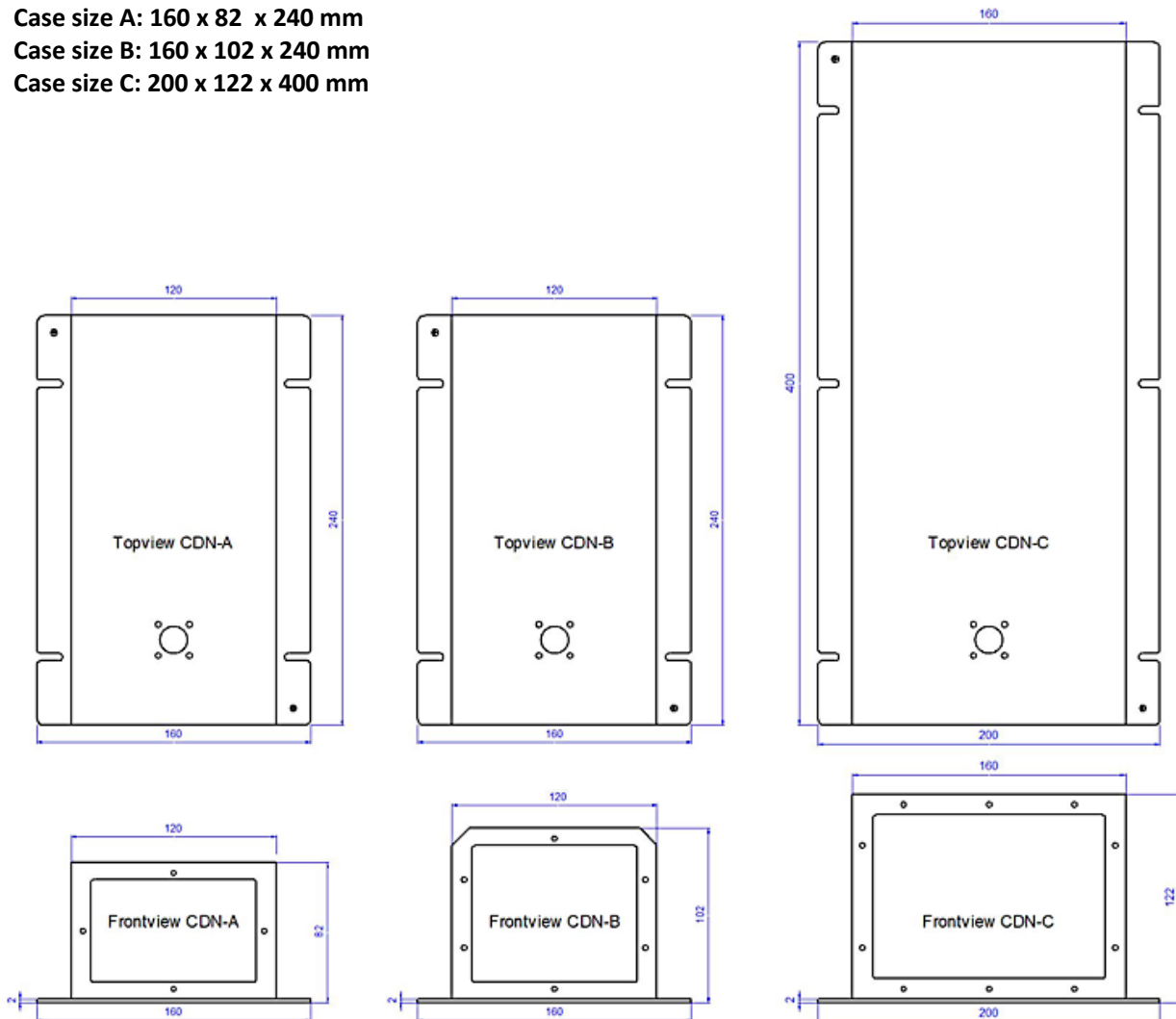

## CDN

### Coupling / Decoupling Network

#### Accessories for calibration set

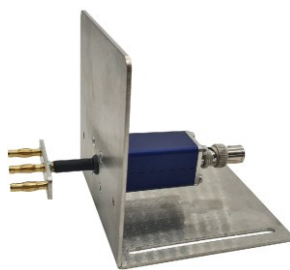

Connection adaptor  
with laboratory plug  
for each CDN

(schematic diagram)

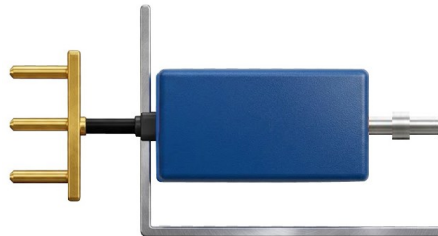

50/150 Ohm adaptor  
with N-connector

Fastening angle

| < - CDG A 41xx -> | < -----CDG A 4100 -----> |

#### To calibrate a coupling network (CDN), the following elements are required (AE and EUT side)\*:

2x CDG A 41xx (corresponding CDN connection adaptors for AE and EUT side)

2x CDG A 4100 (mounting plate + 50/150 Ohm transition with N-connector + 50 Ohm termination for AE side) or

2x CDG 4110 (50/150 Ohm adaptor)

#### The following is required for the first coupling network\*:

2 x CDG A 41xx +

2 x CDG A 4100

#### For each additional coupling network, only two corresponding connection adaptors must be ordered\*:

2 x CDG A 41xx

\*Depending on the signal, termination can be omitted on the AE side. Let us advise you on the details.



# CDN

## Coupling / Decoupling Network

### Dimensions mounting plate

2.5 mm aluminium

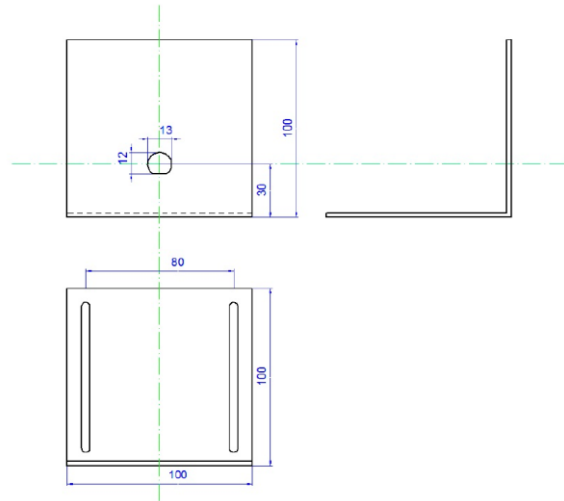

### Insertion loss 150 Ohm to 50 Ohm adaptor (two in series)

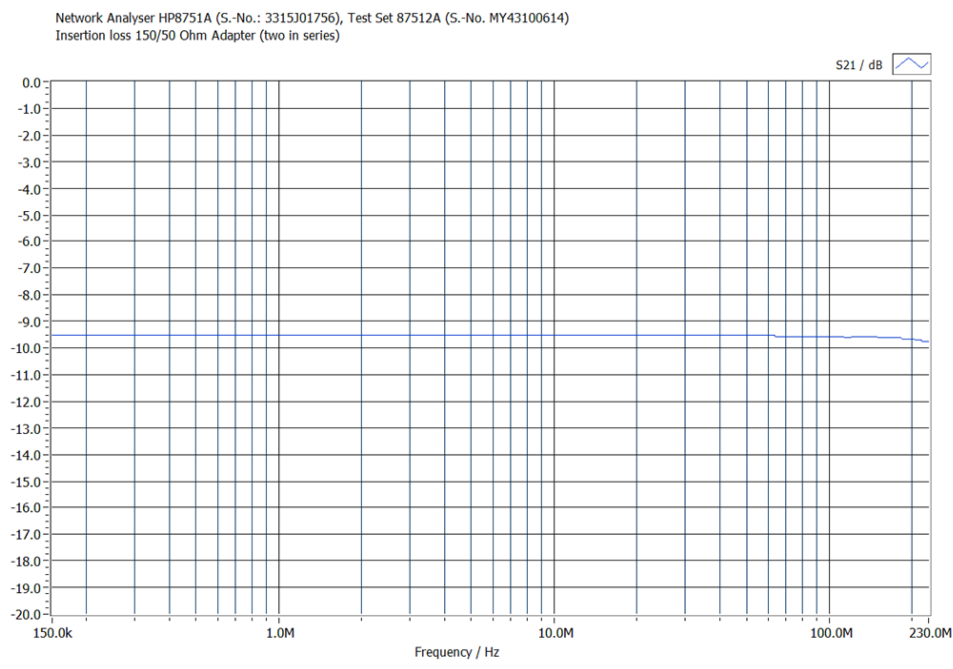

All information regarding appearance and technical data correspond to the current state of development at the time of release of this data sheet. Errors and technical changes excepted. 232606

