

Modulated Wideband Power Amplifier



Frankrijklaan 7, ITC Boskoop
2391 PX HAZERSWOUE DORP
The Netherlands
tel: +31 172 423 000
fax: +31 172 423 009
info@electrometric.com
www.electrometric.com

1 Introduction

Tekbox provides a complete solution for affordable pre-compliance conducted immunity testing: Coupling Decoupling Networks along with suitable calibration adapters and 150 Ohm transitions; BCI probes, suitable modulated wideband power amplifiers and EMCview PRO software. A third-party spectrum analyzer with tracking generator serves as signal source.

The TBMDA5 modulated amplifier provides the necessary power, bandwidth and modulation for conducted immunity testing using CDNs in the frequency range from 150 kHz to 400 MHz. It is designed to be driven by the tracking generator output of spectrum analyzers. With a 1 dB compression point of up to 2.5W in the frequency range 150 kHz to 400 MHz it can generate test levels class 1 and class 2 according to ISO / EN 61000-4-6. A built in AM- modulator enables use of tracking generators as signal source. The TBMDA5 has sufficient gain to achieve maximum output power with 0 dBm provided by a spectrum analyzer tracking generator. Besides 1 kHz, 80% AM, the TBMDA5 provides built in modulation capability to generate 1 kHz, 50% duty cycle PM signals. In PM mode, the TBMDA5 can also generate a 217 Hz Signal with 12.5% duty cycle in order to simulate mobile phone TDMA noise.



Picture 1 – TBMDA5 modulated wideband driver amplifier, front view



Picture 2 – TBMDA5 modulated wideband driver amplifier, rear view

Modulated Wideband Power Amplifier

Application:

General-purpose wideband RF power amplifier

Wideband RF power amplifier for conducted immunity testing driving CDNs or BCI-probes

Wideband RF power amplifier for radiated immunity testing, driving near field probes

Wideband RF power amplifier for radiated immunity testing, driving TEM Cells

Features:

CW amplifier (modulation off)

1 kHz, 80% AM modulation

1 kHz, 50% duty cycle pulse modulation

217 Hz, 12.5% duty cycle pulse modulation

2 Electrical Specifications

Technical Data:

Input / Output: 50 Ohm, N female

Supply Voltage range: 110 V...240 V

Supply power consumption: 19 W @ 220V

Operating temperature range: -20°C to 50°C

Frequency range: 150 kHz – 400 MHz, usable from 100 kHz to 1.2 GHz

Small signal gain: 38 dB typ.

Gain flatness 150 kHz – 400 MHz / Pin = -5 dBm: 3.5 dB typ.

Saturated output power @ 150 kHz / Pin = 0 dBm: 32.6 dBm (1.8 W) typ.

Saturated output power @ 500 kHz / Pin = 0 dBm: 36 dBm (4 W) typ.

Saturated output power @ 1 MHz / Pin = 0 dBm: 36.1 dBm (4.1 W) typ.

Saturated output power @ 10 MHz / Pin = 0 dBm: 37.8 dBm (6 W) typ.

Saturated output power @ 100 MHz / Pin = 0 dBm: 36.4 dBm (4.4 W) typ.

Saturated output power @ 250 MHz / Pin = 0 dBm: 36 dBm (4 W) typ.

Saturated output power @ 400 MHz / Pin = 0 dBm: 33.7 dBm (2.3 W) typ.

Saturated output power @ 750 MHz / Pin = 0 dBm: 33.2 dBm (2.1 W) typ.

Saturated output power @ 1 GHz / Pin = 0 dBm: 34.8 dBm (3 W) typ.

Saturated output power @ 1.1 GHz / Pin = 0 dBm: 31.1 dBm (1.3 W) typ.

Saturated output power @ 1.2 GHz / Pin = 0 dBm: 27.3 dBm (0.5 W) typ.

1dB output compression point @ 150 kHz: +29.6 dBm typ. (Pin: -9 dBm)

1dB output compression point @ 500 kHz: +32.9 dBm typ. (Pin: -6 dBm)

1dB output compression point @ 1 MHz: +33.1 dBm typ. (Pin: -5 dBm)

Modulated Wideband Power Amplifier

1dB output compression point @ 10 MHz: +33.8 dBm typ. (Pin: -6 dBm)
1dB output compression point @ 100 MHz: +33.6 dBm typ. (Pin: -4 dBm)
1dB output compression point @ 250 MHz: +33.1 dBm typ. (Pin: -6 dBm)
1dB output compression point @ 400 MHz: +31.5 dBm typ. (Pin: -6 dBm)
1dB output compression point @ 750 MHz: +30.94 dBm typ. (Pin: -4 dBm)
1dB output compression point @ 1 GHz: +31.8 dBm typ. (Pin: -5 dBm)
1dB output compression point @ 1.1 GHz: +27.9 dBm typ. (Pin: -5 dBm)
1dB output compression point @ 1.2 GHz: +25.2 dBm typ. (Pin: -4 dBm)
2nd harmonic, 100 MHz, Pout=36dBm: < - 15 dBc typ.
2nd harmonic, 100 MHz, Pout=30dBm: < - 22 dBc typ.
3rd harmonic, 100 MHz, Pout=36dBm: < - 23 dBc typ.
3rd harmonic, 100 MHz, Pout=30dBm: < - 33 dBc typ.
Total harmonic distortion:
5.2% @100MHz, Pout=27dBm typ.
8.5% @100 MHz, Pout=30 dBm typ.
14.5% @100 MHz, Pout=33 dBm typ.
20.3% @100 MHz, Pout=36 dBm typ.
Third order output intercept point: +43dBm, @100 MHz, $\Delta f = 2\text{MHz}$, typ.
Noise figure @ 100 MHz: 6.1 dB
Internal modulation frequency AM: 1 kHz $\pm 20\%$
Internal modulation frequencies PM: 1 kHz $\pm 20\%$, 217 Hz $\pm 20\%$
Duty cycle, PM: 50% $\pm 10\%$ @ 1 kHz; 12.5% $\pm 20\%$ @ 217 Hz

Maximum ratings:

Maximum input power: +3 dBm

The output of the TBMDA5 is quite tolerant to output mismatch, however open or shorted load is not recommended, as it potentially can cause damage to the output transistor. When driving near field probes, current probes or any load of unknown impedance, it is highly recommended to insert a 3dB attenuator at the output of the amplifier in order to protect the output stage.

Modulated Wideband Power Amplifier

Gain flatness:

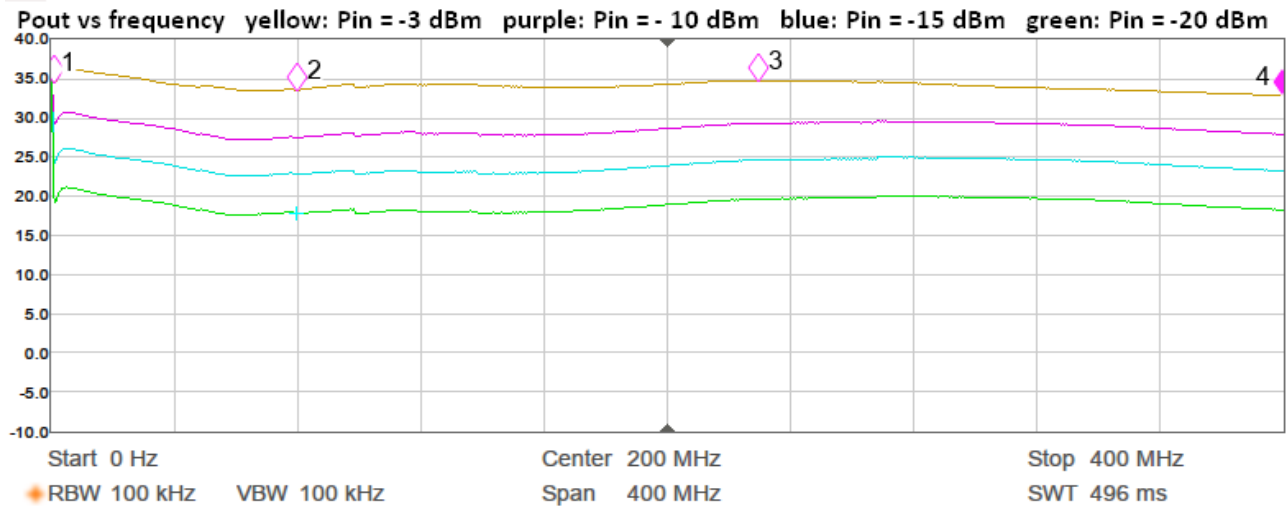

Marker Table

Marker	Type	Trace	Readout	X Axis	Ampt
1	Normal	A	Frequency	1 MHz	34.64 dBm
2	Normal	A	Frequency	80 MHz	33.64 dBm
3	Normal	A	Frequency	230 MHz	34.85 dBm
4	Normal	A	Frequency	400 MHz	32.91 dBm

Small Signal Performance (@ Pin = - 10 dBm):

Frequency [MHz]	0.15	0.5	1	10	80	100	250	400	500	750	1000	1100	1200
Output power [dBm]	28.9	29.7	29.1	30.5	27.9	28.2	29.8	28.1	27.7	26.1	27.7	23.9	20.3
Gain [dB]	38.9	39.7	39.1	40.5	37.9	38.2	39.8	38.1	37.7	36.1	37.7	33.9	30.3

Table 1 – TBMDA5 small signal gain, typ.

1 dB compression point:

Frequency [MHz]	0.15	0.5	1	10	80	100	250	400	500	750	1000	1100	1200
Output power [dBm]	29.6	32.9	33.1	33.8	33	33.6	33.1	31.5	31	31	31.8	27.9	25.2
Pin [dBm]	-9	-6	-5	-6	-5	-5	-6	-6	-6	-4	-5	-5	-4

Table 2 – TBMDA5, 1 dB compression point versus frequency, typ.

Saturation (@ Pin = 0 dBm):

Frequency [MHz]	0.15	0.5	1	10	80	100	250	400	500	750	1000	1100	1200
Output power [dBm]	32.6	36	36.1	37.8	36.1	36.4	36	33.7	32.9	33.2	34.8	31.1	27.3
Gain [dB]	32.6	36	36.1	37.8	36.1	36.4	36	33.7	32.9	33.2	34.8	31.1	27.3

Table 3 – TBMDA5, Saturation versus frequency, typ.

Modulated Wideband Power Amplifier

Modulation:

Zero span, 10 ms sweep time, peak detector

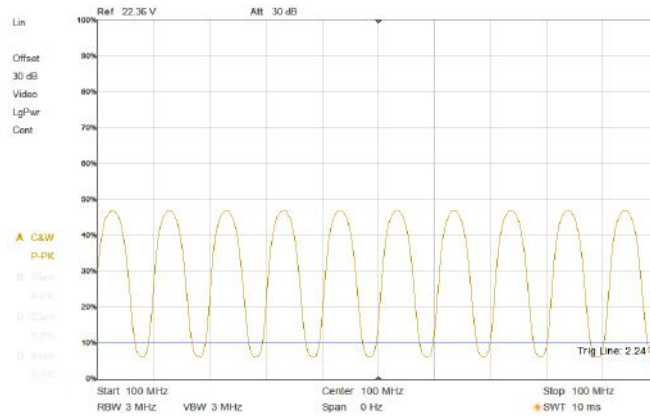

Figure 1 – 1 kHz, 80 % AM, envelope, 100 MHz, Pout = 34 dBm peak;

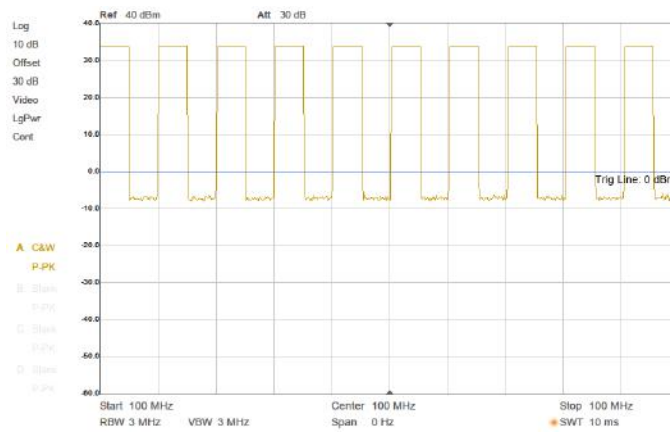

Figure 2 – 1 kHz, 50 % PM envelope, 100 MHz, Pout = 34 dBm peak

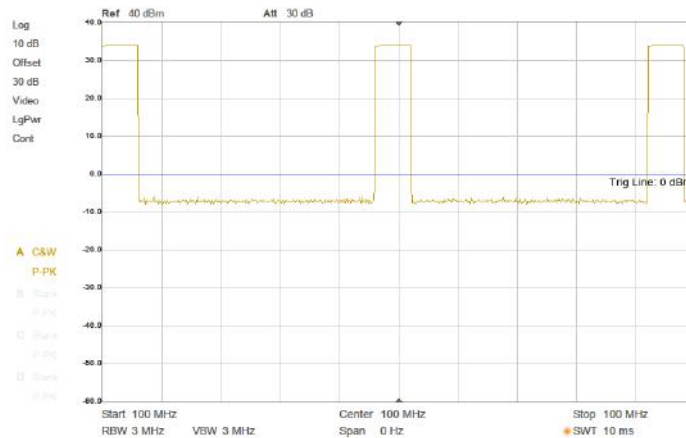

Figure 3 – 217 Hz, 12.5 % PM envelope, 100 MHz, Pout = 34 dBm peak

Modulated Wideband Power Amplifier

3 Applications - radiated immunity

Immunity testing using a TEM cell

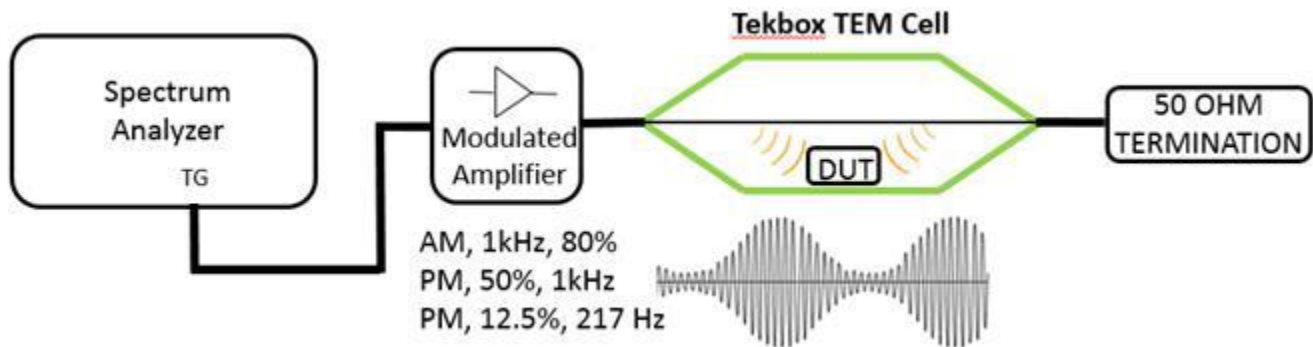

Figure 4 – immunity testing set up

Immunity testing using near field probes

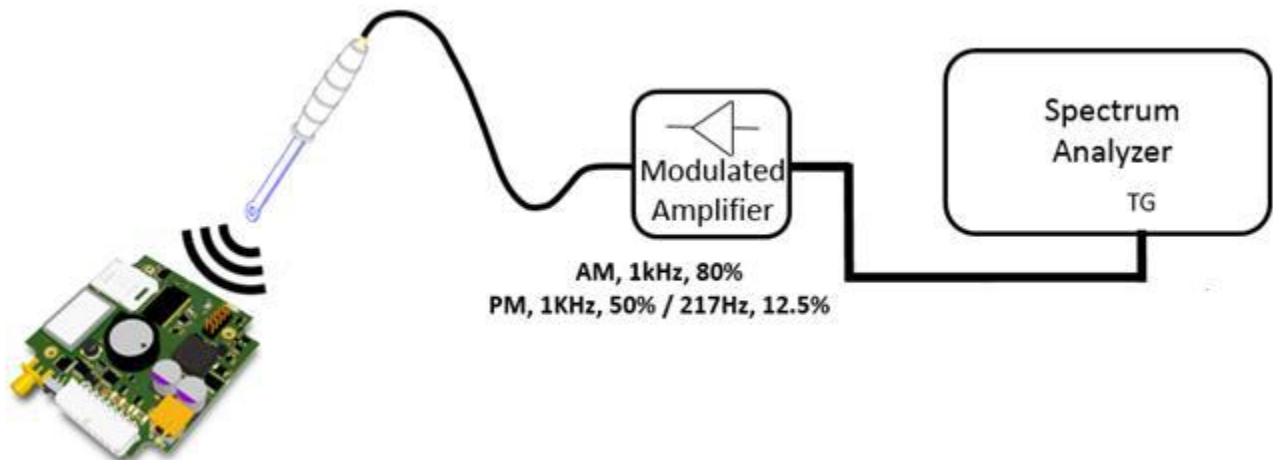

Figure 5 – immunity testing set up to locate susceptible areas on PCBAs

Radiated immunity EMC pre-compliance is typically a 2-step procedure. First, a TEM cell is used to investigate for immunity issues of the DUT. In case of any failure, near-field probes will be used to locate the sensitive circuitry on the PCBA.

Modulated Wideband Power Amplifier

TEM Cell field strength

A typical pre-compliance set up for immunity testing is typically not equipped with an E-field probe to measure the real field strength inside the TEM cell. However, the field strength can be calculated with sufficient accuracy for EMC pre-compliance set-ups.

The E-field (V/m) between septum and lower (upper) wall of a TEM cell is $E = V/d$ where V is the RMS voltage of the applied signal and d is the distance between septum and lower (upper) wall. This is based on the simplified assumption that the E field would be perfectly homogenous/evenly distributed. A more practical formula is $E = V \cdot \text{Cor}/d$ where Cor is a correction factor for the average field strength over the volume of the DUT derived from the analysis of the field distribution over the cross section of the cell.

Assuming the DUT is placed in the center of the cell and in the middle between bottom wall and septum, we can use the simplified formula with sufficient accuracy.

$$\text{TBTC0: } d = 2.8 \text{ cm} \rightarrow E_{[V/m]} = (\sqrt{P \cdot 50\Omega}) \cdot 35.7$$

$$\text{TBTC1: } d = 5 \text{ cm} \rightarrow E_{[V/m]} = (\sqrt{P \cdot 50\Omega}) \cdot 20$$

$$\text{TBTC2: } d = 10 \text{ cm} \rightarrow E_{[V/m]} = (\sqrt{P \cdot 50\Omega}) \cdot 10$$

$$\text{TBTC3: } d = 15 \text{ cm} \rightarrow E_{[V/m]} = (\sqrt{P \cdot 50\Omega}) \cdot 6.66$$

The power P in the formulas above has to be entered in [Watt]

$$P_{[W]} = 0.001 \cdot (10^{(P_{[dBm]}/10)})$$

Frequency [MHz]	Input power [dBm]	Output power [dBm]	Field strength TBTC0 [V/m]	Field strength TBTC1 [V/m]	Field strength TBTC2 [V/m]	Field strength TBTC3 [V/m]
0.15	-3	32.5	337	189	94	63
0.5	-3	34.8	439	246	123	82
1	-3	34.5	424	237	119	79
10	-3	35.8	492	275	138	92
100	-3	34.2	409	229	115	76
250	-3	34.8	439	246	123	82
500	-3	32.4	333	186	93	62
750	-3	31.8	311	174	87	58
1000	-3	33.3	369	207	103	-

Table 4 – calculated field strength for the TBMDA5 driving Tekbox TEM cells

The above output power is the RMS output power in case of a CW signal. Note that in case of 80% AM modulation, the RMS power of the modulated signal will be 5.1 dB lower than the RMS power of the CW signal.

Modulated Wideband Power Amplifier

4 Applications - conducted immunity, using CDNs

EN 61000-4-6 calibration set up using EMCview PRO

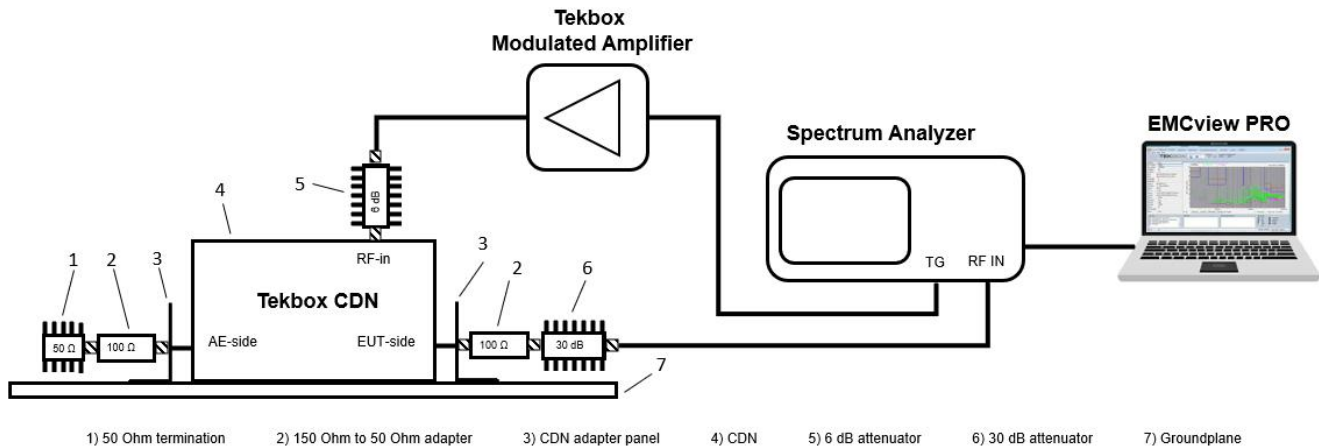

- Test Level 1: 1V RMS, 1 kHz / 80% AM modulated
- Test Level 2: 3V RMS, 1 kHz / 80% AM modulated
- Test Level 3: 10V RMS, 1 kHz / 80% AM modulated
- Test Level X: special (unspecified)

The specified test levels are open circuit voltages at the EUT port of the CDN.

The voltages measured during calibration must be multiplied by 3 to allow for the 50 Ohm to 150 Ohm conversion and again by 2 to reach the open circuit voltage.

Hence, the measured voltage at the output of the 150 Ohm to 50 Ohm adapter is 1/6th the voltage of the desired stress level. In logarithmic figures, the measured voltage is 15.5 dB lower than the open circuit voltage.

Example: Test level 2

$U_0 = 3V$ RMS open circuit voltage at the EUT port of the CDN = $3V/6 = 0.5V$ RMS at the output of the 100 Ohm to 50 Ohm adapter.

The required power at the output of the modulated amplifier is:

$U_0/6$ [dBm] + CDN insertion loss + 6 dB (Attenuator) + 5.1 dB (80% AM RMS)

Assuming 10 dB insertion loss for the CDN, the required RF power is:

7 dBm + 10 dB + 6 dB + 5.1 dB = 28.1 dBm = 0.65 Watt

During calibration, EMCview Pro will make a stepped sweep, for each frequency adjusting the tracking generator level in order to achieve 7 dBm + 5.1 dB - 30 dB = -17.9 dBm at the spectrum analyzer input. The tracking generator level table will then be used to set levels during the actual immunity test.

Modulated Wideband Power Amplifier

Note that the above calculation does not include tolerances of the cable, attenuator and CDN.

Test levels that can be achieved with the TBMDA5:

Amplifier model	Modulation	Attenuator	Test levels	Freq. Range
TBMDA5	AM 80%, 1 kHz	6 dB	Level 1, Level 2	150 kHz – 230 MHz
	AM 80%, 1 kHz	3 dB	Level 1, Level 2, 5V	150 kHz – 230 MHz

EN 61000-4-6 immunity test set up using EMCview PRO

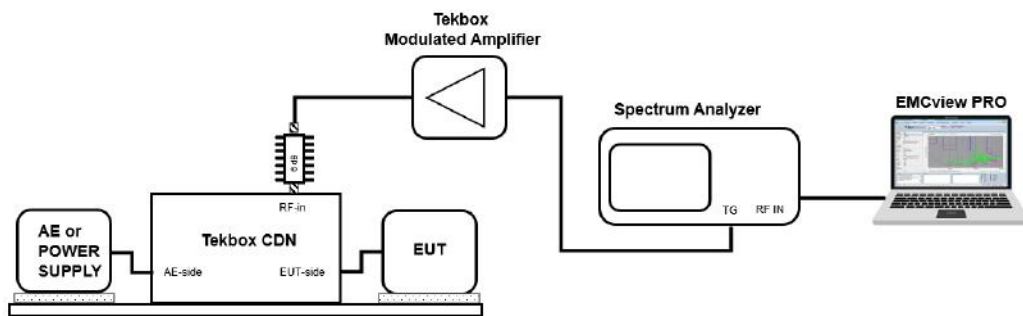

Set up the CDN and DUT as shown above. In EMCview PRO, load the file created during calibration and press the Play-button to run the immunity test.

5 Applications - conducted immunity, using BCI probes

EN 61000-4-6 300 Ohm loop BCI calibration set up using EMCview PRO

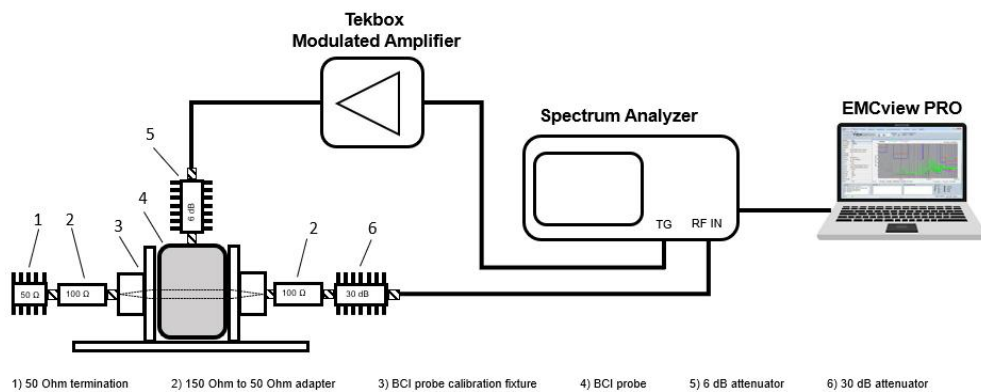

- Test Level 1: 1V RMS, 1 kHz / 80% AM modulated
- Test Level 2: 3V RMS, 1 kHz / 80% AM modulated
- Test Level 3: 10V RMS, 1 kHz / 80% AM modulated
- Test Level X: special (unspecified)

Modulated Wideband Power Amplifier

The specified test levels are open circuit voltages at the output of the calibration fixture.

The voltages measured during calibration must be multiplied by 3 to allow for the 50 Ohm to 150 Ohm conversion and again by 2 to reach the open circuit voltage.

Hence, the measured voltage at the output of the 150 Ohm to 50 Ohm adapter is 1/6th the voltage of the desired stress level. In logarithmic figures, the measured voltage is 15.5 dB lower than the open circuit voltage.

Example: Test level 1 $U_0 = 1V$ RMS open circuit voltage at the output of the calibration fixture = $1V/6 = 0.166V$ RMS at the output of the 100 Ohm to 50 Ohm adapter.

The required power at the output of the modulated amplifier is:

$U_0/6$ [dBm] + BCI probe insertion loss + 6 dB (Attenuator) + 5.1 dB (80% AM RMS)

Assuming 16 dB insertion loss for the BCI probe in a 300 Ohm loop, the required RF power is:

$-2.55 \text{ dBm} + 16 \text{ dB} + 6 \text{ dB} + 5.1 \text{ dB} = 24.55 \text{ dBm} = 0.28 \text{ Watt}$

During calibration, EMCview Pro will make a stepped sweep, for each frequency adjusting the tracking generator level in order to achieve $-2.55 \text{ dBm} + 5.1 \text{ dB} - 30 \text{ dB} = -27.55 \text{ dBm}$ at the spectrum analyzer input. The tracking generator level table will then be used to set levels during the actual immunity test.

Note that the calculation does not include any tolerances of the BCI probe, attenuator and cable. The BCI probe within the 300 Ohm loop has a higher coupling loss compared to the probe within a 50 Ohm system. It will exceed the 16 dB used for the above example at frequencies below 500kHz.

The BCI method requires significantly more power than the CDN method, to achieve the same stress levels. Test levels that can be achieved with the TBMDA5:

Amplifier model	Modulation	Attenuator	Test levels	Freq. Range
TBMDA5	AM 80%, 1 kHz	6 dB	Level 1, Level 2	500 kHz – 230 MHz
	AM 80%, 1 kHz	3 dB	Level 1, Level 2, 4V	500 kHz – 230 MHz

EN 61000-4-6 immunity test set up using a BCI probe and EMCview PRO

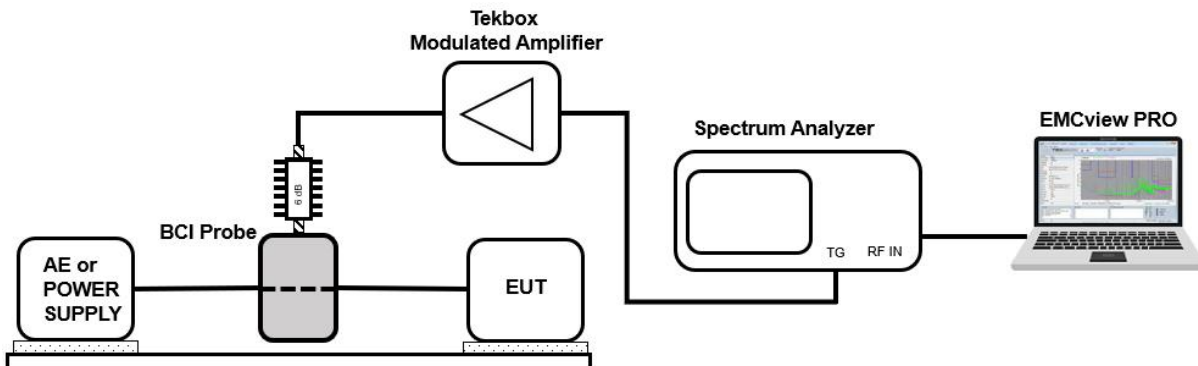

Set up the test equipment and DUT as shown above. In EMCview PRO, load the file created during calibration and press the Play-button to run the immunity test.

Modulated Wideband Power Amplifier

ISO 11452-4 substitution method using EMCview PRO

The automotive immunity standard ISO 11452-4 as well as immunity standards for defense and avionic products specify stress levels in terms of induced disturbance current.

Traditional calibration and test methods use current monitoring probes in order to create a control loop, thereby maintaining the required disturbance current. Levelling loops can be fooled by cable resonances. High impedance resonances cause the RF amplifiers output power to raise, in order to achieve the specified disturbance current. Similarly, low impedance resonances may significantly reduce the RF amplifiers output power. This situation is unrealistic of most real-life electromagnetic environments and could create a severe over-test or under-test situation.

In order to get around the over-test / under-test problems associated with the closed loop test method, the standards offer the substitution method (open loop), where the disturbance current is set by measuring current induced into a 100 Ohm loop. Forward and reflected power is measured using a directional coupler while setting the RF power to achieve the required disturbance current levels into the 50 Ohm load. During actual immunity test, the forward power level is set according to the value recorded during calibration.

Substitution calibration method set up for pre-compliance purpose:

Substitution method, calibration, step 1

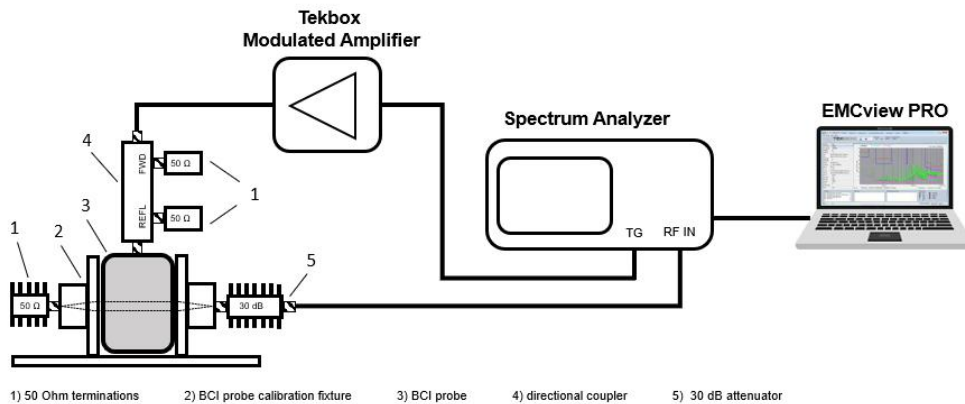

Substitution method, calibration, step 2

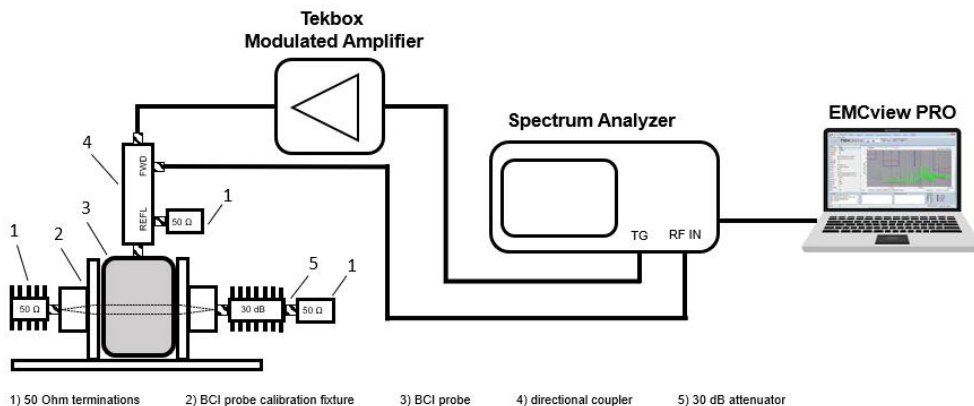

Modulated Wideband Power Amplifier

Example: Test level I – 60 mA

A power of 22.6 dBm is required to achieve a current of 60 mA in a 50 Ohm load.

Assume 8dB insertion loss for a typical BCI probe in a 100 Ohm loop.

Assume 1 dB insertion loss for the directional coupler

The required power at the output of the modulated amplifier is:

Test level [dBm] + BCI probe insertion loss + 6 dB (Attenuator) + 5.1 dB (80% AM RMS)

22.6 dBm + 8 dB + 1 dB + 5.1 dB = 36,7 dBm = 4.7 W

Example: Test level IV – 200 mA

A power of 33 dBm is required to achieve a current of 200 mA in a 50 Ohm load.

Assume 8dB insertion loss for a typical BCI probe in a 100 Ohm loop.

Assume 1 dB insertion loss for the directional coupler

The required power at the output of the modulated amplifier is:

Test level [dBm] + BCI probe insertion loss + 6 dB (Attenuator) + 5.1 dB (80% AM RMS)

33 dBm + 8 dB + 1 dB + 5.1 dB = 47.1 dBm = 51.3 W

Test levels that can be achieved with the TBMDA5:

Amplifier model	Modulation	Test levels	Freq. Range
TBMDA5	AM 80%, 1 kHz	50 mA	1 MHz - 400 MHz
	CW	Level I, Level II	1 MHz - 400 MHz

Substitution method, immunity test

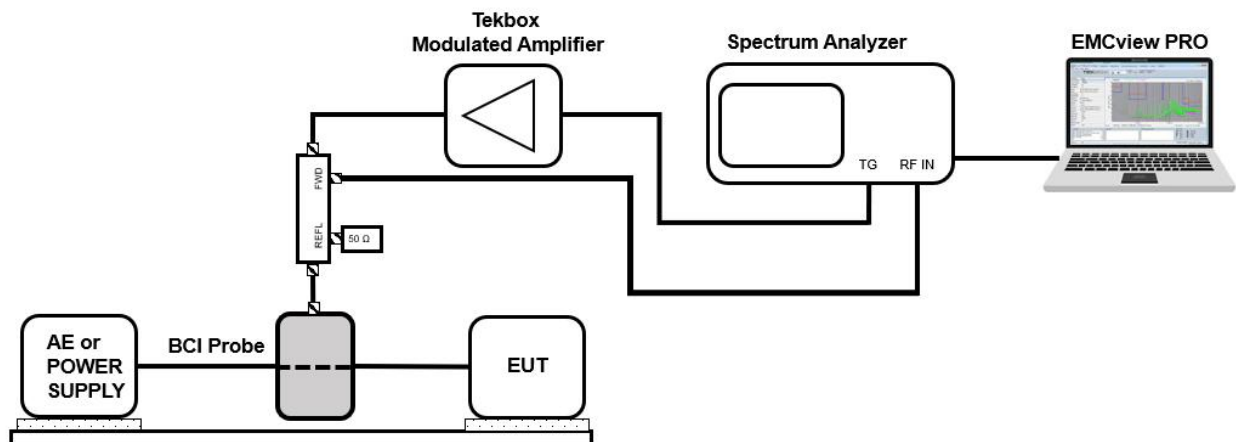

Set up the test equipment and DUT as shown above. In EMCview PRO, load the file created during calibration and press the Play-button to run the immunity test.

Modulated Wideband Power Amplifier

ISO 11452-4 closed loop method using EMCview PRO

The Closed Loop Method controls the injected current by measuring the actual injected current using a current probe.

The injected current depends on the impedance of the EUT and cable and may not be achievable for any frequency, especially if ungrounded EUTs are used. At parallel resonances of the cable, the impedance will become very high and maintaining the set current level might exceed the capabilities of the RF power amplifier. This is a common issue associated with the closed loop method.

The currently available modulated amplifiers from Tekbox do not provide sufficient power, except perhaps for Level I. Typically, amplifiers with 100 – 250W output power are used for closed loop immunity tests.

6 PC Software for immunity testing

Tekbox provides two software versions for EMC pre-compliance measurements

EMCview provides a feature to control the tracking generator output frequency and level and carry out sweeps with constant tracking generator level.

EMCview PRO provides a more sophisticated feature, which is able to carry out calibration sweeps for CDN and BCI based set ups. The resulting calibration file is used to set the tracking generator level during the immunity test sweep.

Tekbox EMCview currently supports Rigol, Siglent, Owon, R&S FPC and FPH series spectrum analyzers. Refer to the EMCview website for the latest list of supported models

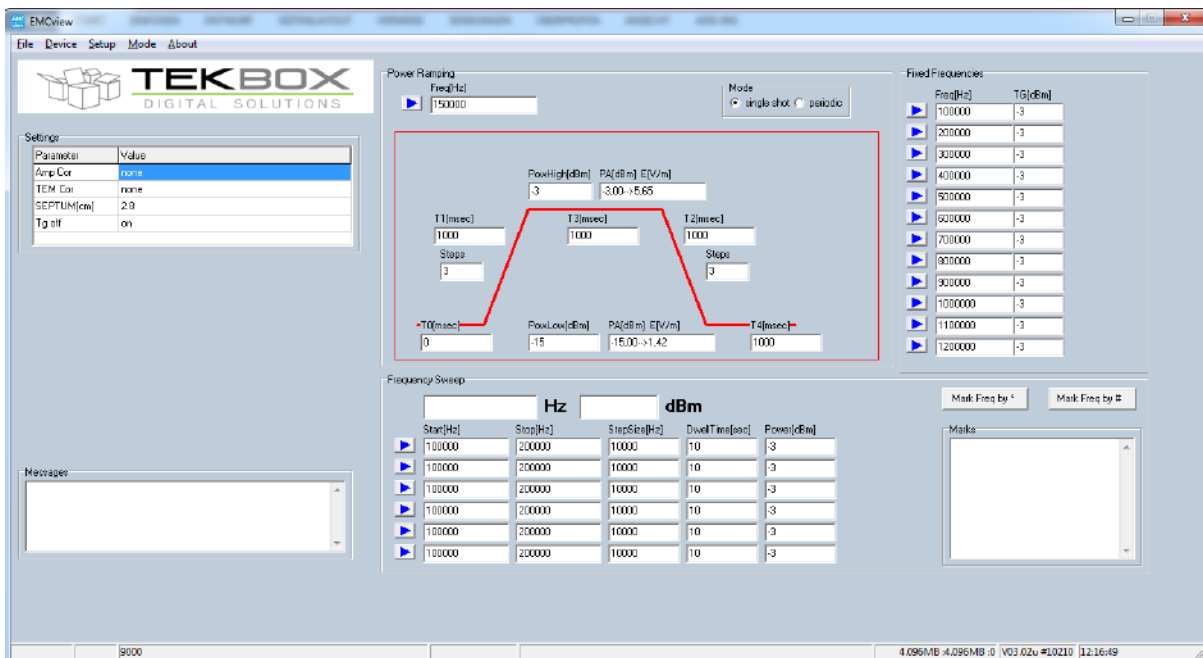

screenshot of the tracking generator control feature of EMCview / EMCview Pro

Modulated Wideband Power Amplifier

Immunity Test Setup Calibration

Parameter	Value
Freq Start[Hz]	150000
Freq Stop[Hz]	80000000
Freq Step[%]	10
Calibration Level [dBm]	-7.45

Calibrate Abort Calibration Save Calibration File

Calibration Setup Calculator

EN 61000-4-6 CDN EN 61000-4-6 BCI ISO 11452-4 SM ISO 11452-4 CL

Level 3 Required RF power[dBm][W] 38.55 dBm = 7.16 W

Calibration Level[dBm] 7.45

Immunity Measurement EN 61000-4-6 CDN

Parameter	Value
Calibration	none
Freq Start Sweep[Hz]	150000
Freq Stop Sweep[Hz]	80000000
Freq Step Sweep[%]	1
Dwell Time Sweep[s]	1
Constant Frequency[Hz]	150000
Mode	sweep

TG ON during pause

Freq:

Messages

TG:

screenshot of the CDN immunity test feature of EMCview Pro

Immunity Test Setup Calibration

Parameter	Value
Freq Start[Hz]	150000
Freq Stop[Hz]	80000000
Freq Step[%]	10
Calibration Level [dBm]	-17.91

Calibrate Abort Calibration Save Calibration File

Calibration Setup Calculator

EN 61000-4-6 CDN EN 61000-4-6 BCI ISO 11452-4 SM ISO 11452-4 CL

Level 2 Required RF power[dBm][W] 35.09 dBm = 3.23 W

Calibration Level[dBm] 17.91

Immunity Measurement EN 61000-4-6 BCI

Parameter	Value
Calibration	none
Freq Start Sweep[Hz]	150000
Freq Stop Sweep[Hz]	80000000
Freq Step Sweep[%]	1
Dwell Time Sweep[s]	1
Constant Frequency[Hz]	150000
Mode	sweep
Current Probe	none

TG ON during pause

Current monitoring

Freq:

Messages

TG:

screenshot of the EN 61000-4-6 BCI immunity test feature of EMCview Pro

Modulated Wideband Power Amplifier

Immunity Test Setup Calibration

Parameter	Value
Freq Start[Hz]	1000000
Freq Stop[Hz]	400000000
Freq Step[%]	10
Calibration Level [dBm]	-7.45
VSWR Bridge	none

Calibrate Abort Calibration Save Calibration File

Immunity Measurement ISO 11452-4 SM

Parameter	Value
Calibration	none
Freq Start Sweep[Hz]	1000000
Freq Stop Sweep[Hz]	400000000
Freq Step Sweep[%]	1
Dwell Time Sweep[s]	1
Constant Frequency[Hz]	1000000
Mode	sweep

TG ON during pause

Calibration Setup Calculator

EN 61000-4-6 CDN EN 61000-4-6 BCI ISO 11452-4 SM ISO 11452-4 CL

Substitution method, calibration, step 1

Level I

RMS [dBm] Peak [dBm]

-7.45 -7.45

Messages

Clear Save

TG:

screenshot of the ISO 11452-4 substitution method immunity test feature of EMCview Pro

Immunity Measurement ISO 11452-4 CL

Parameter	Value
Freq Start Sweep[Hz]	1000000
Freq Stop Sweep[Hz]	400000000
Freq Step Sweep[%]	1
Dwell Time Sweep[s]	1
Constant Frequency[Hz]	1000000
Mode	sweep
Level [mA]	60
Current Probe	none

TG ON during pause

Calibration Setup Calculator

EN 61000-4-6 CDN EN 61000-4-6 BCI ISO 11452-4 SM ISO 11452-4 CL

Closed Loop Method

Level I

RMS [mA] Peak [mA]

60 60

Messages

Clear Save Chart

TG:

screenshot of the ISO 11452-4 closed loop immunity test feature of EMCview Pro

Modulated Wideband Power Amplifier

WARNING:

Never connect the output of the TBMDA5 directly to the input of a spectrum analyzer. Check the maximum input ratings of the spectrum analyzer and protect it with an appropriate attenuator. Open or shorted load is not recommended, potentially can cause damage of the RF output stage.

Example:

Rigol DSA815 – maximum input power rating: +20dBm

7 Ordering Information

Part Number	Description
TBMDA5-EU	modulated power amplifier, 2 pcs 75cm N-male to N-male cables, 1 pc 6 dB attenuator, 1 pc 30dB / 10W attenuator with N-connectors, C13 Schuko power cord
TBMDA5-US	modulated power amplifier, 2 pcs 75cm N-male to N-male cables, 1 pc 6 dB attenuator, 1 pc 30dB / 10W attenuator with N-connectors, C13 US power cord
TBMDA5-UK	modulated power amplifier, 2 pcs 75cm N-male to N-male cables, 1 pc 6 dB attenuator, 1 pc 30dB / 10W attenuator with N-connectors, C13 English power cord
TBMDA5-AU	modulated power amplifier, 2 pcs 75cm N-male to N-male cables, 1 pc 6 dB attenuator, 1 pc 30dB / 10W attenuator with N-connectors, C13 Australian power cord

Table 5 – Ordering Information

8 History

Version	Date	Author	Changes
V1.0	5.10.2022	Mayerhofer	Creation of the document
V1.1	25.11.2022	Minh Nguyen	Update Ordering Information
V1.2	25.12.2023	Mayerhofer	Update of chapters 4, 5, 6

Table 6 – History

www.tekbox.com

TekBox Digital Solutions Vietnam Pte. Ltd.

Factory 4, F5, Lot I-3B-1, Saigon Hi-Tech Park, Tan Phu Ward, District 9, Ho Chi Minh City, Vietnam

