

IEC 60601-1-2 ED. 4.1 / IEC 61000-4-39

New requirement, immunity to proximity magnetic fields based on IEC 61000-4-39

Equipment designed for the task



The IEC 60601-1-2 standard is the international standard for testing medical equipment to EMC. The latest update adds a new test as more transmitter products are present in homes, offices (locations where medical equipment may be used), and hospitals. Three frequencies that are in use are: 30 kHz, 134.2 kHz, and 13.56 MHz. The standard IEC 61000-4-39 for testing fields in close proximity is referenced for this testing. With our IEC 60601-1-2 setup these test fields can be produced.

Requirements IEC 60601-1-2

Test Frequency	Modulation	Immunity Test Level (A/m)
30 kHz	CW	8
134,2 kHz	Pulse Modulation 2,1 kHz	65
13,56 MHz	Pulse Modulation 50 kHz	7,5

Requirements IEC 61000-4-39

Frequency range	9 kHz to 150 kHz	150 kHz to 26 MHz
Level	Test field strength (A/m)	Test field strength (A/m)
1	1	0,1
2	3	0,3
3	10	1
4	30	3
X	Special	Special
Modulation	AM	PM
Frequency	1 kHz	2 Hz, 1 kHz
Parameter	80%	50% duty cycle



IEC 60601-1-2 ED. 4.1 / IEC 61000-4-39

New requirement, immunity to proximity magnetic fields based on IEC 61000-4-39

The magnetic loops are specified in IEC 61000-4-39 and are readily available. However, producing a field through the loops might not be straight forward. The loop impedance changes over its frequency range, and the amplifier being used will not match this impedance. The result would be a much higher power requirement. In this case, we are not covering a frequency range but individual frequency points. This allows a matching network to be created to match the loop to the amplifier's impedance.

Basic Setup

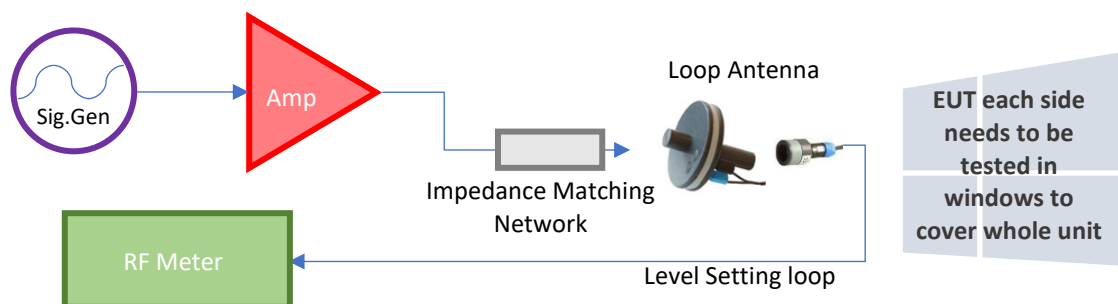

Schlöder has created a system to match this requirement. The system is computer-controlled to set the field level and perform testing with report generation.

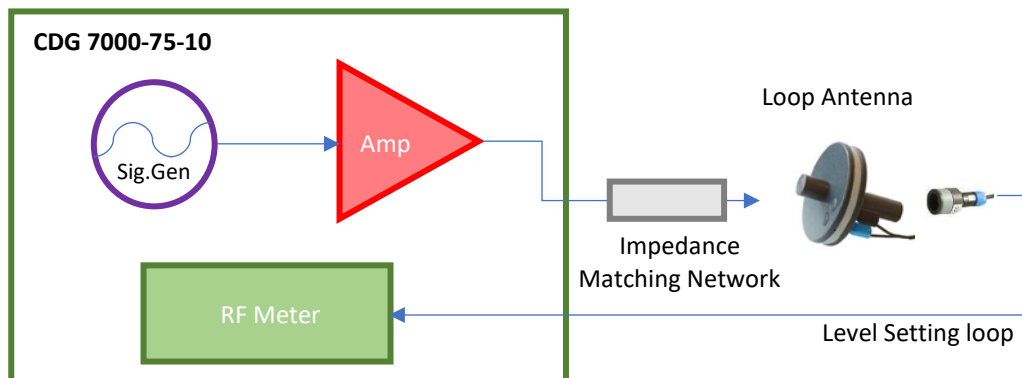

IEC 60601-1-2 ED. 4.1 / IEC 61000-4-39

New requirement, immunity to proximity magnetic fields based on IEC 61000-4-39

Required Equipment	
Generator and measurement	CDG 7000-75-10 - 10 kHz – 250 MHz, 75 Watt, amplifier, RF Generator, RF Meter x3 (monitored level, forward & reverse power). The system includes all cabling and HELIA 7 software required to meet the standard's requirements
Accessories 9 kHz – 150 kHz	<ul style="list-style-type: none"> ▪ MGA RL 120 – Radiating loop 120 mm as specified in IEC 61000-4-39 for 9 kHz-150 kHz, IEC / EN 60601-1-2 and MIL-STD-461 / RS101, 3 m cable ▪ MGA LS 040 – Loop sensor 40 mm that attaches to MGA RL 120 at the correct distance of 50 mm ▪ MGA RL 120 NW – Matching Network for MGA RL 120, matches loop to 50 Ohms of the CDG 7000 amplifier acc. to IEC 61000-4-39 and IEC / EN 60601-1-2 for Immunity to magnetic fields 9 kHz - 150 kHz
Accessories 150 kHz – 26 MHz	<ul style="list-style-type: none"> ▪ MGA RL-100-3 – Radiating loop as specified in IEC 61000-4-39 and IEC / EN 60601-1-2 for 150 kHz – 26 MHz ▪ MGA LS-040-1 – Loop sensor 40 mm that attaches to MGA RL 100-3 at the correct distance of 50 mm as specified in IEC 61000-4-39 and IEC / EN 60601-1-2 ▪ MGA RL 100-3 NW-60601 – Matching Network 60601 for MGA RL 100-3, matches MGA RL 100-3 to the IEC 60601-1-2 requirements ▪ MGA RL 100-3 NW-61000 – Matching Network 61000 for MGA RL 100-3, matches MGA RL 100-3 to the IEC 61000-4-39 requirements

Options	
MGA RL 100-3 Stand	Stand for MGA RL-100-3 for tests
MGA RL 120-3 Stand	Stand for MGA RL-120-3 for tests

Added system advantage	
EUT monitoring:	with Digital TTL signals & analog 0-10 VDC (automate threshold and report)
EUT Fail port:	Stop test or mark report
SCPI interface control for universal support (11452-4)	
Conducted immunity testing to IEC 61000-4-6, ISO, MIL, and other standards with the use of additional accessories CDNs, EMC clamps, BCI Clamps	

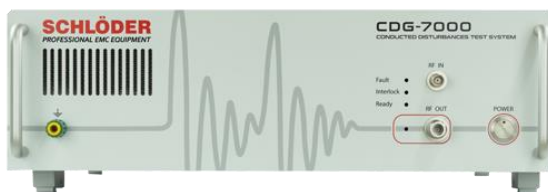

All information regarding appearance and technical data correspond to the current state of development at the time of release of this data sheet. We reserve the right to make technical changes. 292103

