



EV Powertrain Testing Challenges & Solutions

Introduction

As the electrification of the automobile continues to accelerate, automotive engineers must address new testing challenges for powertrains of Battery Electric Vehicles (BEV) that did not exist with traditional powertrains. In this application note, we will review several different testbed approaches to supply the electrical power controls. We'll also look at the advantages of modern battery emulators for testing new vehicle propulsion subsystems. Finally, we will highlight why NH Research is the best choice for next-generation battery emulation solutions.

What is an Electric-Vehicle (EV) Powertrain?

Electrification in the transportation industry has generated new developments in vehicle propulsion architecture. Initially, an EV powertrain looked quite similar to a traditional propulsion system having an engine (motor), transmission, fuel source (electricity), and mechanical frame. More recent developments include replacing the internal-combustion engine (ICE) with one or more electric motors, using new forms of transmissions and torque control, and improvements in energy storage (batteries) to act as the fuel source. All new powertrain components as well as complete skateboards (motor, transmission, and frame) are rigorously tested under harsh conditions to ensure high reliability. A modern EV powertrain is shown in the picture below.



Image: Courtesy of Lucid Motors

New Challenges in Testing BEV Powertrains

Modern propulsion system architectures are fundamentally different and present new challenges and different risks. In normal operation, traditional combustion-based powertrains required petroleum-based fuels and emitted toxic fumes, both of which had to be carefully controlled. By comparison, an EV powertrain has no toxic elements or emissions under normal operation but does require additional safety considerations such as high voltage training, fixturing, and handling. Additionally, using the real battery to test the motors and mechanical systems includes some risk of failure in which the failed device could release toxic gases and caustic (corrosive) fluids, and could vent exothermically (smoke, fire, explosion). Simply put, it makes more sense to use a battery emulator to replace the energy storage component to reduce these risks. This approach improves safety, reduces test time, and provides more repeatable results.

EV Powertrains have different safety considerations when compared to traditional propulsion systems

Common Test Setups - Dynamometers, the DC-Bus & Using Modern Battery Emulation

When testing components (sensors, transmissions, or other mechanical devices) it is common to have a test-stand (testbed) with a drive motor to simulate the mechanical power of the motor/engine and a second drive motor to simulate the mechanical loading/inertial of the wheels. When testing a full skateboard, the drive motor is included in the skateboard, requiring only a secondary motor to simulate the wheels. This second configuration is often referred to as a dynamometer (“dyno” for short), and has been used for many years to test traditional ICE vehicles. Similarly, early-EV powertrains were unidirectional power flows making it possible to use a traditional power supply to act like the battery and to use a traditional dyno to absorb the mechanical power generated by loading the secondary drive motor.

These early EV powertrain testing approaches quickly evolved to a common DC bus topology as shown in **Figure 1**. This topology attempts to capture and reuse electrical power rather than dissipating it as heat (waste). Since it is based on one or more unidirectional devices, any failure or performance limitation (UUT or device) breaks the entire test setup. Moreover, back-EMF during ramp-down or simulated engine braking can result in device damage. Finally, there is no isolation between the input and output allowing noise, harmonics, or other instabilities on either to affect the DC bus as well as the output or input respectively. All of these factors can easily skew test results and create false powertrain conditions.

Unlike the traditional method described above, NHR’s modern battery emulation approach provides a unique bidirectional solution that better simulates real world conditions for energy storage (battery) and wheel power. Shown in **Figure 2**, this bidirectional approach provides isolation between the input and output, eliminates single points of failure in the test setup, and automatically accepts any back-EMF generated by the UUT. Unlike the common DC bus in **Figure 1**, the separate input and output paths of **Figure 2** remove uncertainty from the test and allow the test engineers to analyze performance parameters more easily. This superior approach is especially important for regenerative braking, engine inertia energy capture, and other situations requiring short bursts of power-flow in either direction.

NHR’s approach automatically accepts back-EMF power flows from regenerative braking, engine inertia capture and short bursts of power.

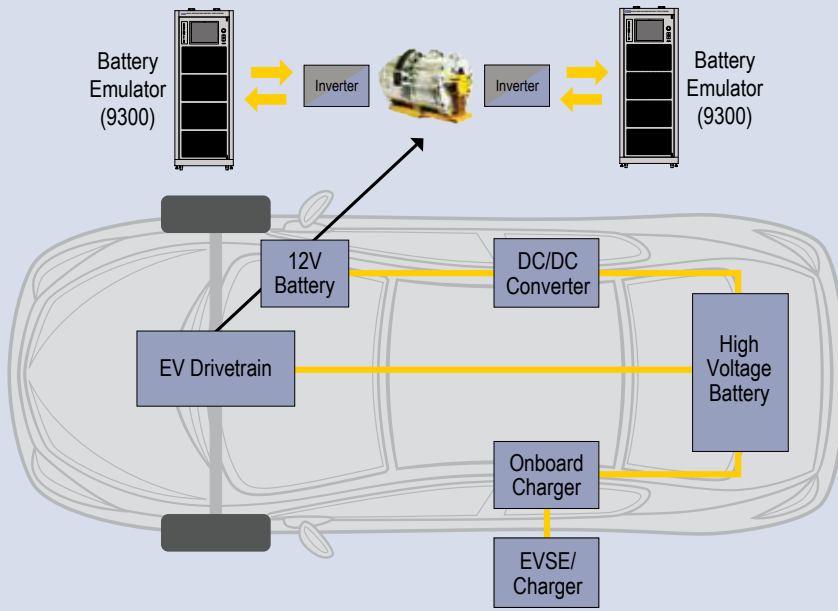

Image: EV block diagram

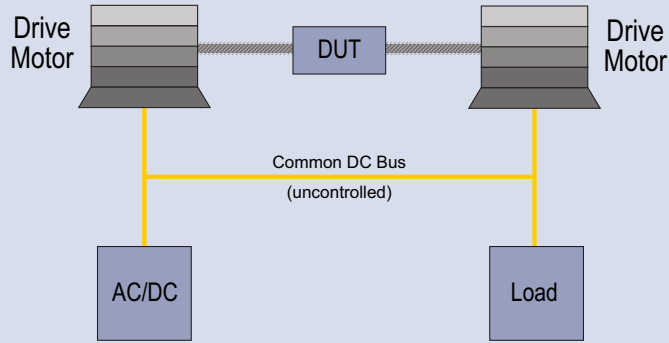

Figure 1: Common DC bus

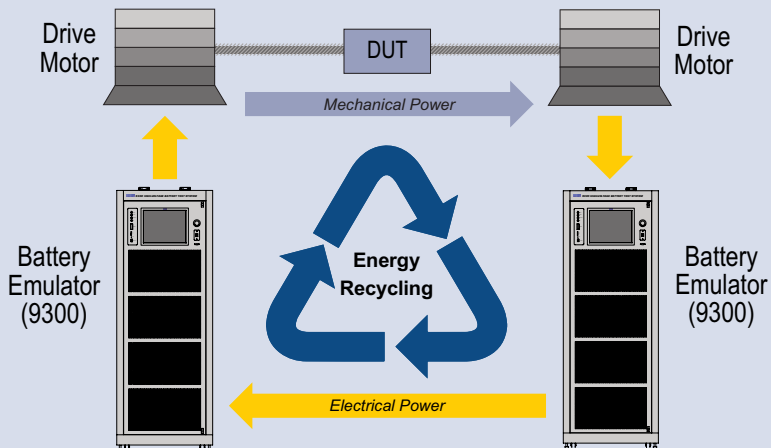

Figure 2: Powertrain battery simulation

Changing Power & Voltage Levels in Modern BEV Powertrain

Power and voltage levels are transitioning from a traditional 300/400VDC level toward 800/1000VDC. Higher voltages permit faster charging and increase power transfer while reducing vehicle weight. For example, in 2019 most available BEVs were similar to Tesla's Model 3 and GM's Chevy Bolt, with a nominal voltage of ~350VDC, whereas Porsche announced the Taycan architecture utilizing a higher 800VDC battery system. This higher voltage allows nearly three times (3x) the additional power to be transferred for the same wire size. Porsche demonstrated this with an IONITY system charging at 350kW, which is nearly 3x the 120kW available through other "fast" supercharging networks.



Image: Courtesy of Volkswagen Group (Porsche)



Image: Courtesy of Tesla Motors

It is expected that both 800V and 350V vehicles will charge at an electric-only refueling station the same way gasoline and diesel cars do today. Engineers should keep this dual-voltage reality in mind when specifying the power requirements because many of the high-power test systems are only designed for a single range. Selecting a system that can provide both traditional and high-voltage levels ensures that the right equipment is available to meet current and future needs. It is equally important that a battery emulation system reacts with a quick voltage response to changes in current or power draw in order to accurately simulate the electrical storage system (battery).

Auto manufacturers have dramatically increased the relative capacity of the battery packs in their vehicles to reduce "range anxiety". For example, the 2019 Nissan Leaf has a 50% larger battery compared to older 40kW models, and Tesla's Model S offers a 100kW battery, that is 66% larger than the original standard-sized battery. Battery capacity and battery performance are always improving, suggesting that engineers must consider flexibility and programmability in selecting a battery emulation solution. In particular, test engineers will not want to compromise by using no resistance or fixed resistance values. If this compromise is made, all testing fails to accurately simulate today's batteries and will certainly not accurately simulate tomorrow's improved batteries.

A battery emulation system must react with a quick voltage response to changes in current or power draw.

How is a Battery Emulator Different from Power Supplies & Electronic Loads?

Battery emulators are bidirectional, whereas power supplies and loads are unidirectional devices. A power supply regulates voltage and expects some amount of current to be drawn. Loads regulate current and expect voltage to be provided. Being unidirectional, these devices are unable to accept or supply power in the reverse direction.

An approach engineers often take is to build their own test setup using sources and loads. This can be challenging, and time consuming, and has many of the disadvantages of the common DC bus architecture described above. Typically, DC sources have a programmed response time of 10 to 100 ms, which is far too slow for today's EV powertrains. Using a DC load to modulate power or provide a return path for back-EMF requires complicated software development, considerable integration and test time, and does not provide an accurate simulation of the battery's internal resistance. Additionally, the load must consume power at all times, and since it is not regenerative, all of the power is dissipated as heat (waste), increasing operating costs and creating uncomfortable work conditions.

Battery emulators maintain a positive DC voltage and can immediately accept or deliver current, allowing power to flow in either direction. More advanced battery emulators, like NHR's 9300, allow further real-world simulation of battery characteristics by modeling the battery packs series-resistance (RINT), which is discussed in detail in the next section.



Image: Automated Test System using source & load circa 2006

Battery emulators maintain a positive DC voltage and can immediately accept or deliver current, allowing power to flow in either direction.

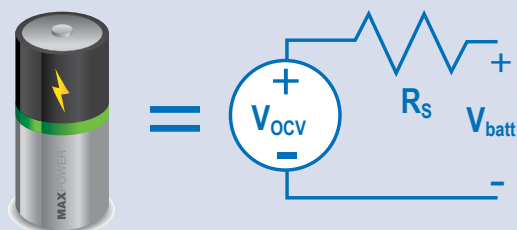

Figure 3: The RINT Model (versus other models)

The RINT Model - Accurately Simulating Battery Characteristics

The Internal Resistance (RINT) model provides a simulation of the battery's internal chemical resistance, along with additional pack resistances created by internal connections, contactors, and safety components. As seen in **Figure 3**, the RINT model can be implemented with a true bi-directional source (V_{ocv}) and a programmable series-resistance (R_s). This model is sufficient for understanding the major characteristics of battery-based resistances and pack resistances when testing powertrain systems. While the number of mathematical models has increased, these more complicated models are used to understand the electro-chemical characteristics of batteries, the nuances of the which have little impact on the overall system when compared with the total resistance of the pack.

The NH Research battery emulation system features this equivalent RINT Model providing an electronically programmable "Battery Emulation" mode. Requiring only two simple terms (V_{ocv} & R_s), the battery emulation automatically adjusts the terminal voltage (V_{batt}) based on the direction and level of current (I_{charge}).

$$V_{batt} = V_{ocv} + R_s \cdot I_{charge}$$

Performance Demonstration of Series Resistance Effect (RINT Model)

As in a real battery, NHR's battery emulators adjust the output voltage depending on the direction and amplitude of current flow. Current is shown as red in **Figure 4**, starting with current being drawn from the simulated battery (50A), increasing to a higher current (100A), and finally dropping to zero. The output was set to simulate 5mΩ of resistance, and the output voltage (shown in blue) shows the output tracking these current changes and providing the appropriate terminal voltage drop. This automatic adjustment of output voltage better simulates real-world battery pack characteristics especially when compared with common DC-bus and source/load simulation systems.

As in a real battery, NHR's battery emulators adjust the output voltage automatically depending on the direction and amplitude of current flow.

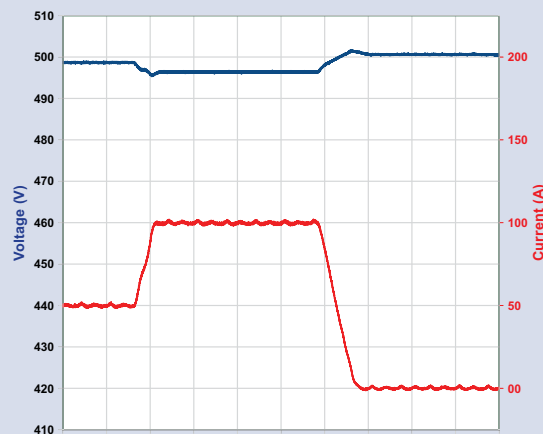

Figure 4: Performance for RINT Model

NHR's Flexible Solution

The battery emulation systems from NHR are modular, meeting the voltage and current levels required by your testing needs. Higher-power models provide dual ranges, allowing the equipment to emulate today's batteries and provide the right tool that grows along with increases in battery voltage and power. Furthermore, NH Research provides a wide range of software control options, allowing this power stage to be fully integrated with dynamometer and other test system components.

Modularity

All NHR battery emulation systems are designed for fully independent operation and can be paralleled, increasing the maximum power and current capability to the level required. This modular expansion through paralleling ensures that you can start testing to today's application levels, knowing that additional power is available if needed in the future. For example as shown in **Figure 5**, three systems can be operated as three separate test channels, one test channel at three times (3x) the power, or configured as two channels with one acting as a two times (2x) power and the other as a separate test channel. The 9300 system permits up to 24 channels to be combined in this way for a maximum total power of 2.4 megawatts. Systems are future-proofed, sized for today's needs and for future power levels, without requiring the entire system to be replaced.



Figure 5: Systems are future proofed

NHR also manufactures lower power systems with a wide range of voltage options. This modular system – the 9200 Series- is expandable in 8kW/12kW block sizes and has voltage options from 40V to 600VDC. This series uses the same drivers, touch panel controls, and software options, making NH Research your ideal solution partner for both high-power and low-power battery emulation systems.

Systems are future-proofed, sized for the needs of today and the future...

Dual Ranges

Unlike competitive systems that are often purpose built, NHR's 9300 high power test system ensures long-term value by providing a dual range as shown in **Figure 6**. This means that the full 100kW power per module is available from 300 -600V in the high current range as well as from 600 -1200V in the high voltage range. Dual ranges ensure that today's EV drive trains (400 -500V) and next-generation models (800 -1000V) can be easily tested using the same capital equipment.

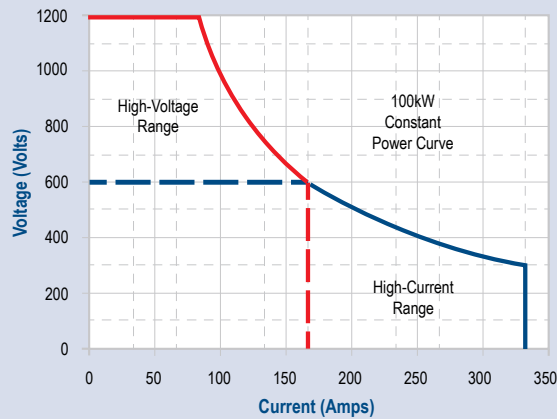

Figure 6: Dual Range covers BEV power levels

Easy Integration: Software Control Options & Integration Partners

All NHR battery emulators can be easily integrated into existing test platforms or as the power stage for new test platforms. To achieve this, NHR provides fully documented drivers using either IVI or SCPI languages along with examples, applications, and integration support. NHR also has a number of integration partners who are familiar with our hardware and can deliver a full turn-key test system. These integrators develop fully custom systems utilizing your specified hardware sensors and fixturing components.

Accurate Battery Simulation & Energy Savings

All NHR battery emulators implement the RINT model, or series resistance effect, to provide the most accurate battery simulation. Furthermore, NHR's battery emulation solutions are regenerative, meaning any power flowing into the system is recycled into clean, usable facility power.

NHR battery emulators are easily integrated into existing test platforms or used as the power stage for new test platforms.

Summary

EV powertrains are evolving and have new testing challenges. Voltage and power levels are changing due to fast charging and vehicle performance. Traditional powertrain test approaches rely on unidirectional devices that have drawbacks and limitations. Modern battery emulation is a bidirectional approach that is isolated, can handle back-EMF, and is a more robust topology.

The best choice for powertrain testing is NHR’s next-generation battery emulation solution. It provides all of the following:

- Flexibility to address changing voltage needs
- Scalability to address future power levels
- A series resistance model to simulate a battery more accurately
- Faster response times than DC power supplies
- Easier integration and software control
- Reduced energy costs

Summary of EV Powertrain Test Approaches

	TRADITIONAL		MODERN
	Build Your Own	Common DC-Bus	NHR’s Next-Gen Battery Emulation
Bidirectional	-	-	●
Accepts Back-EMF	-	-	●
Works for Short Power Burst	-	-	●
Accurate Battery Simulation	-	◐	●
Ease of Integration	-	◐	●
Scalable Power	◐	◐	●
Addresses Voltage Ranges	◐	◐	●
Conserves Energy	-	●	●
Addresses EV Powertrain	●	●	●



16601 Hale Avenue, Irvine, California 92606
Tel: (949) 474-3900
E-mail: sales@nhresearch.com

www.nhresearch.com

© Copyright 2019, NH Research Inc. 03-0029 Pub. 01-31-19 JC
All rights reserved. Specifications subject to change without notice.