



MULTIPLIER
PRODUCTS

MULTIPLIER
PRODUCTS

MULTIPLIER
PRODUCTS

MULTIPLIER
PRODUCTS

MULTIPLIER
PRODUCTS

MULTIPLIER
PRODUCTS

MULTIPLIER
PRODUCTS

MULTIPLIER
PRODUCTS

MULTIPLIER
PRODUCTS

MULTIPLIER
PRODUCTS

MULTIPLIER
PRODUCTS

MULTIPLIER
PRODUCTS

MULTIPLIER
PRODUCTS

MULTIPLIER
PRODUCTS

MULTIPLIER
PRODUCTS

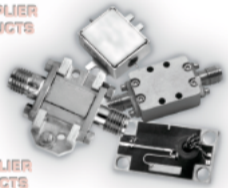

- PASSIVE FREQUENCY DOUBLERS
- ACTIVE FREQUENCY DOUBLERS
- SELECT BANDWIDTH DOUBLERS AND TRIPLERS
- ACTIVE FREQUENCY TRIPLERS
- HIGHER ORDER ACTIVE MULTIPLIERS



Table of Contents



Technical Overview



Application Notes



Quick Reference



Detailed Data Sheets



Higher-Order Active Assem.



Outline Drawings

TABLE OF CONTENTS

CONTENTS

CONTENTS

CONTENTS

MULTIPLIERS

- Introduction
- Technical Overview
- Technical Discussion
- Design Example
- Specification Definitions
- Defining Multiplier Terms
- Typical Block Diagrams
- Specifications and Typical Values
- Environmental Conditions
- Percentage Bandwidth, Rejection and Size
- Active Frequency Multipliers
- Common Applications
- Quick Reference
 - Passive Frequency Doublers
 - Active Frequency Doublers
 - Select Bandwidth Doublers and Triplers
 - Active Frequency Triplers
 - High Order Active Multipliers
 - Comb Multiplier Designs
- Detailed Data Sheets
 - Passive Frequency Doublers
 - Octave Bandwidth
 - Millimeter
 - Multi-octave Bandwidth
 - Drop-In
 - Active Frequency Doublers
 - Narrow and Octave Bandwidth
 - Drop-In
 - Millimeter
 - Multi-octave Bandwidth
 - Millimeter
- Active Multiplier Assemblies
 - X2
 - Millimeter
 - X3
 - Millimeter
 - X4
 - Millimeter
 - X5
- Higher Order Multiplication (X20)
- SRD Comb Generator
- Higher Order Multiplication (X4)
- Outline Drawings
 - Passive Multipliers
 - Active Multipliers
 - Passive Multipliers
- Questions and Answers

INTRODUCTION

This section is intended to provide an overview of MITEQ's passive and active multiplier capabilities. Within this catalog you will find a variety of standard designs which will meet typical applications. However, MITEQ maintains dedicated engineering resources to modify these standard designs in support of custom-generated specifications that are typically required in stringent system applications. These critical requirements often require high spectral purity. MITEQ can obtain high levels of fundamental and spurious signal

suppression as required in many frequency source applications by employing special filter technologies.

In addition to custom-filter designs, MITEQ also has advanced amplifier technologies which, when combined with balanced multiplier designs, offer high performance active multipliers especially in the areas of shaped frequency response and desired output levels.

TECHNICAL OVERVIEW

Most of MITEQ's frequency multiplier designs perform to specific customer requirements and cannot easily be categorized into standard products. Parameters such as frequency range, bandwidth, spurious rejection and multiplication ratios are normally determined by specific system requirements. These requirements, in turn, translate into custom-designed filter and amplifier specifications at the multiplier design level.

In most frequency multiplier designs, the multiplier output contains, besides the desired harmonic output, unwanted signals. These unwanted signals consist of the fundamental input signal leakage, and lower-order and higher-order harmonics generated in the multiplier. Quite often with odd-order multipliers, the undesired signals are higher in level than the desired signal. In even-order multipliers, the undesired outputs are normally 10 to 20 dB below the desired output. Thus, the output signals can be amplified before the output is filtered. This is not possible with odd-order multipliers because the unwanted signals will cause the amplifier to saturate and suppress the desired output.

Definitions of key performance parameters vary from manufacturer to manufacturer. Some of the variations are minor, while others can lead to misinterpretations of specifications. In order to avoid that problem and facilitate the use of this catalog, we have supplied a technical discussion for our series of passive and active multipliers.

MULTIPLIER LOSSES

The basic multiplier losses of MITEQ's passive multipliers are listed below;

times two (X 2):	12 dB typical
times three (X 3):	17 dB typical
times four (X 4):	22 dB typical
times five (X 5):	23 dB typical

MITEQ's active multipliers are formed by cascading a passive multiplier and an active device, such as an amplifier. Multipliers of higher orders are formed by cascading these basic blocks. The most common higher-order multiplier used for MITEQ's systems applications is the times six, which is formed with the cascade of times two and times three. MITEQ manufactures C-band through Ku-band multipliers with built-in comb bandpass filters, MMIC amplifiers and higher-order assemblies that include various combinations of even- and odd-harmonic multipliers.

PHASE NOISE

MITEQ multipliers add phase noise to a lower frequency source by approximately $20 \times \log [N] + 3$ dB, where N is the multiplication factor. If spurious products are present on an incoming signal, they increase in level by this factor. Below is a visual representation of this phenomenon:

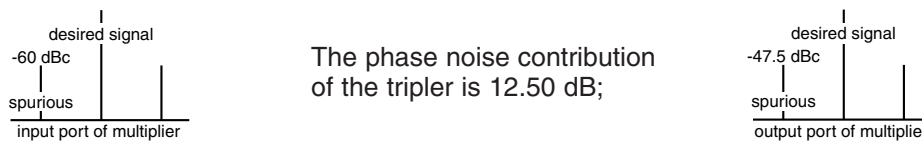

One method of measuring the phase noise contribution is referred to as a residual phase noise measurement and requires three multipliers (three measurements with two multipliers each), so that the source noise is cancelled. At present, all of our multipliers have not been thoroughly characterized for phase noise contribution.

SPURIOUS AND HARMONIC REJECTION

The concepts of harmonic rejection and spurious rejection are very important in the manufacture of multipliers. An important tool in the design process relates to the spurious-free bandwidth, which can be mathematically calculated from the relation:

$$[N + 1] / N \leq [\text{upper frequency limit} / \text{lower frequency limit}]$$

where N is the multiplication factor.

For a tripler, this ratio becomes $4/3 = 1.333$. A tripler whose output is 4 to 8 GHz wide has inband spurious outputs that are not filtered because $8/4 = 2$, which exceeds the spurious-free bandwidth ratio.

With regard to spurious rejection, it makes a difference over what output region the rejection is required. Generally, MITEQ produces multipliers with -65 dBc minimum spurious rejection not only in the output passband, but also outside the desired passband from (1 to 18 GHz). Spurious outputs take three basic forms.

- CASE 1. The spurs are not harmonically related to the input and are called nonharmonically-related spurs [not related to N at all].
- CASE 2. The spurs are related somehow to the input, or multiples of it, and are called harmonically-related spurious. [N + 1, N - 1, N + 2, etc.].
- CASE 3. The spurs are related to multiples of the output and are referred to as output harmonics [N, 3N, 4N, etc.].

At MITEQ, we refer to the first two cases under the general term spurious rejection and to case three by the term output harmonics. Rejection to output harmonics for the vast majority of MITEQ multipliers lies between -15 and -20 dBc. The reason for this is because those multipliers that require amplification usually employ an amplifier that is run in a saturated mode to minimize output power variations versus temperature.

This leads to a key design concept about properly assessing the choice of multiplication factor, and more importantly, how much rejection is required to meet your overall system requirements. The multiplier can be used as part of a synthesizer or source that feeds one port of a mixer. When the spurs of the multiplier enter the mixer, they mix with the RF and its harmonics to produce various unwanted signals that cannot be filtered in the IF passband.

DESIGN EXAMPLE

Your system requires a multiplier output from 8.6 to 10.5 GHz. Due to the available input frequencies, it is determined that the multiplication factor is six times. This is best accomplished by cascading a times three and a times two multiplier.

The input required for the tripler will be 1433 to 1750 MHz.

Multiples of the input, present at the output are:

X 2	2866 – 3500 MHz
X 3	4299 – 5250 MHz [desired]
X 4	5732 – 7000 MHz
X 5	7165 – 8750 MHz etc...

Suppose that the times five spectral component at the output is not suppressed properly. If your system specification is -70 dBc spurious, for example, and the $N + 2$ product is only suppressed by -58 dBc, the times six chain will not meet specification, because the next doubler will not provide any additional suppression. This product is an inband spurious because anything from 8600 to 10500 MHz is inband.

Suppose, next, that the $N + 1$ product of the tripler is not suppressed -70 dBc. The desired input to the doubler is 4299 to 5250 MHz, but we also have an input from 5732 to 7000 MHz that was not adequately suppressed. Therefore, we will observe an undesired output from the doubler at the following frequency:

$N + 1$	5732 – 7000 MHz
N	4299 – 5250 MHz, the difference product is 1433 – 1750 MHz

Since our desired output is 8600 to 10500 MHz, the difference product maps into the region (8600 to 10500 MHz) + (1433 to 1750 MHz) and the result is 10033 to 12250 MHz, which is an undesired product, from at least the 10033 to 10500 MHz region of the desired output passband.

The point of this example is to show that when a multiplier system is designed from cascaded multipliers, potential problems exist if you buy the individual multipliers separately from MITEQ and do not take into account all the multiples and their products formed at various stages. MITEQ provides custom-designed higher-order multipliers that will not suffer from these effects.

SPECIFICATION DEFINITIONS

PASSIVE MULTIPLIERS

CONVERSION LOSS (also known as multiplier loss)

This is the attenuation in dB between the input level and the output level.

HARMONIC REJECTION

The difference in dB between the desired harmonic and the unwanted harmonic as viewed at the multiplier output port. When the unwanted harmonic is the fundamental itself, then the difference is the fundamental rejection.

ACTIVE MULTIPLIERS

CONVERSION GAIN

The net increase in power between the fundamental input signal and the desired output. It is usually expressed as a positive ratio in dB.

SPURIOUS REJECTION

The difference in dB between the desired output harmonic and any other harmonic as viewed at the multiplier's output. The spurs can be multiples of the input frequency.

OUTPUT HARMONIC REJECTION

The difference in dB between the desired output and harmonics of the output frequency.

COMMON DEFINITIONS FOR BOTH PASSIVE AND ACTIVE MULTIPLIERS

OUTPUT POWER FLATNESS

The maximum power variation in dB over a specified frequency and at a specific temperature.

INPUT POWER

The level in dBm as measured at the multiplier's input port.

OUTPUT POWER

The level in dBm as measured at the output port of the multiplier.

OPERATING TEMPERATURE

The temperature range at which the device meets the specified electrical parameters. The temperature is defined as the base plate temperature of the device.

DEFINING MULTIPLIER TERMS

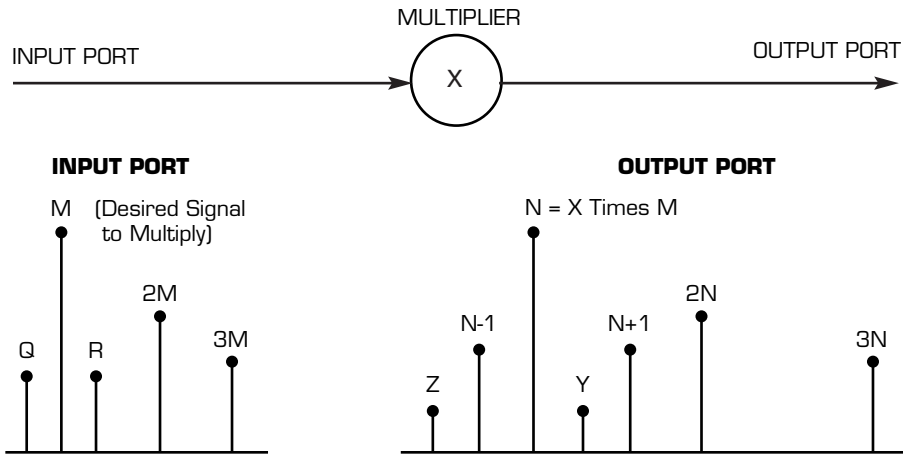

Input harmonics feeding multiplier = $2M, 3M$
 Spurious feeding multiplier = Q, R

Output harmonics from multiplier = $2N, 3N$
 Input harmonic rejection (products generated in the multiplier) = $N + 1, N - 1$ related to the input
 Spurious rejection = Y, Z

TYPICAL BLOCK DIAGRAMS

The basic use of frequency multipliers is to extend the output frequency range or bandwidth of a source by multiplying that frequency by a given multiplication factor, i.e., twice the fundamental of a 5 to 10 GHz source would yield a 10 to 20 GHz output. The following block diagrams represent but a small sampling of the uses for both passive and active multipliers.

PASSIVE MULTIPLIERS

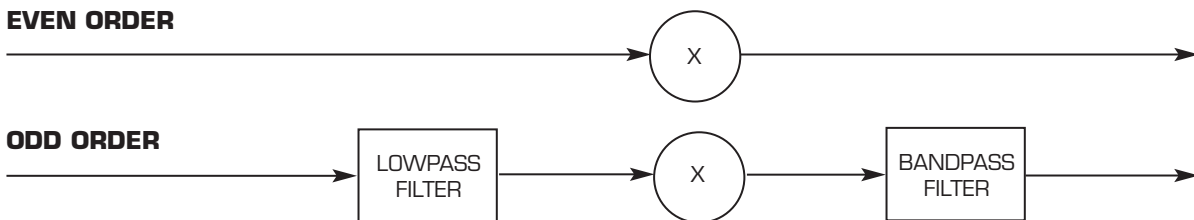

ACTIVE MULTIPLIERS

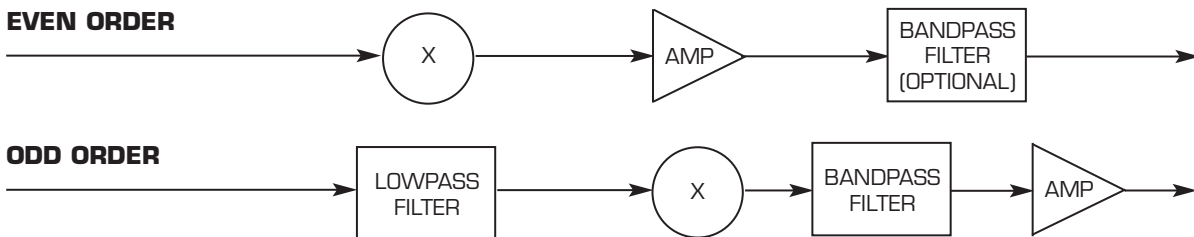

TYPICAL BLOCK DIAGRAMS (CONT.)

TIMES 2 MULTIPLIER WITH SOURCE

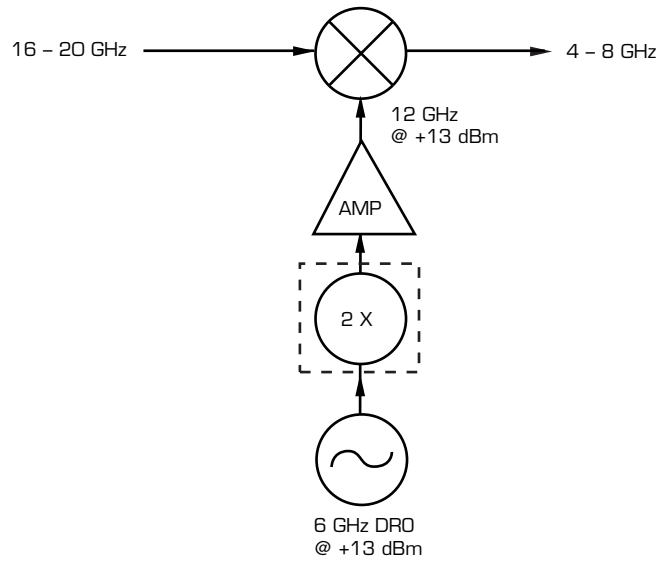

SUBSYSTEM WITH MULTIPLIERS

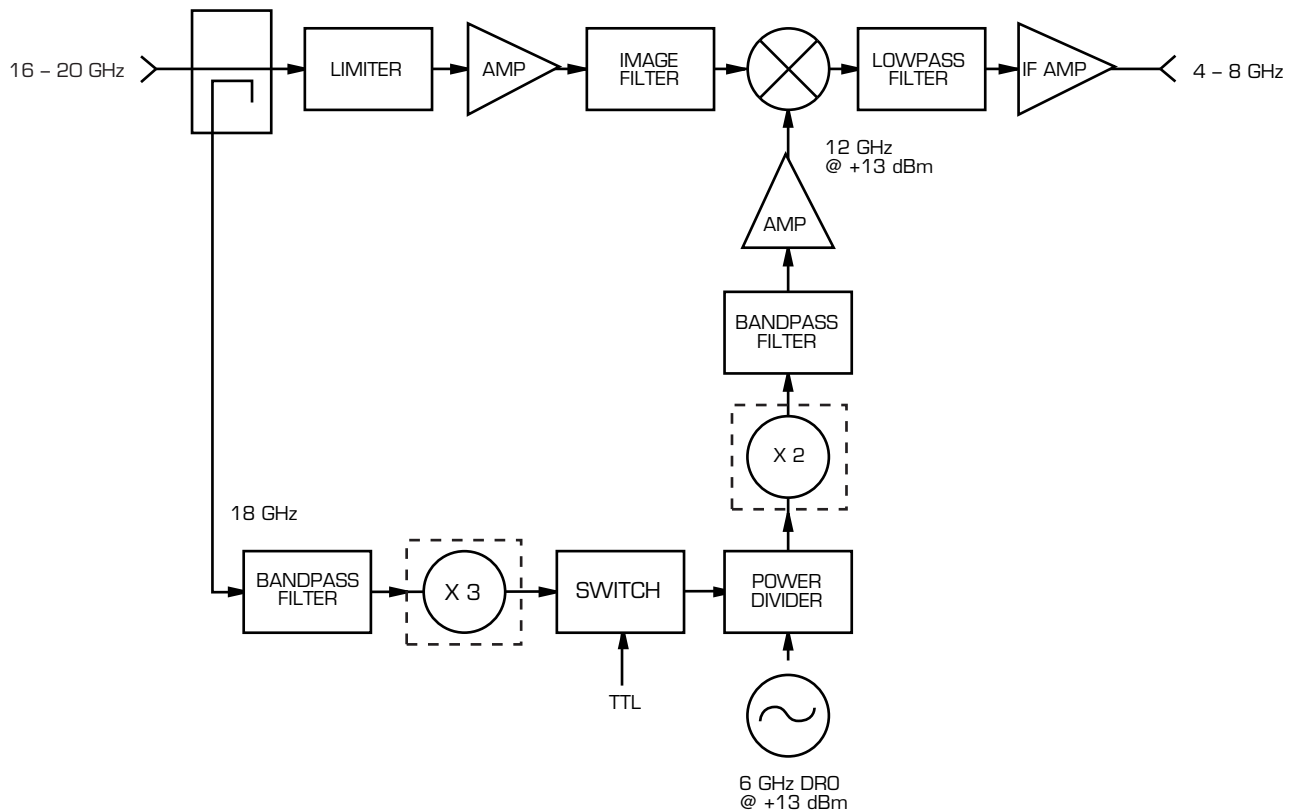

SPECIFICATIONS AND TYPICAL VALUES

One very common problem MITEQ's customers face when purchasing multipliers is not knowing what specifications are practically realizable, and also not appreciating that over specification causes large, bulky and expensive products. This can be overcome by using some practical values established here as a reference:

SPECIFICATION	TYPICAL VALUE
Multiplication factor	Examine spurious-free bandwidth ratio
Phase noise contribution	$20 \log [N] + 3 \text{ dB}$
Output bandwidth	Examine spurious-free bandwidth ratio
Input power	+10 dBm
Output power	+10 dBm
Output power flatness	$\pm 1.50 \text{ dB}$
Spurious rejection	-50 to -60 dBc for designs with filters
Output harmonics	-15 dBc
Operating temperature	0 to 50°C
Size	Depends on required rejection

ENVIRONMENTAL CONDITIONS

MITEQ's standard frequency multipliers have been designed to meet the following environmental conditions:

Operating temperature	-30 to +75°C
Storage temperature	-40 to +85°C
Humidity	95% relative humidity, noncondensing
Vibration	7 g's rms, 50-5000 CPS, per MIL-STD-810B, Method 514, Procedure 5
Data curves are at 25°C	There will be some variation in the typical data shown as a function of temperature

PERCENTAGE BANDWIDTH, REJECTION AND SIZE

The last topic to address is perhaps the most complicated. It relates to having some feel for how large a multiplier will be in order to achieve proper spurious rejection. Two diagnostic tools used at MITEQ are presented here, which have played an important role in this regard:

Multiplier Percentage Bandwidth = $[\text{Output Bandwidth}] / [\text{Operating Frequency}]$
MITEQ produces designs with 10 to 15 percent bandwidths.

Bandwidth Ratio = $[\text{Reject Frequency} - \text{Center Frequency}] / [\text{Output Bandwidth}]$
Generally, the higher the number the better.

When the percentage bandwidth gets too large, and/or when the bandwidth ratio gets too small, the multiplier becomes difficult to produce and may become quite large because the filtering requirements are forcing the number of filtering elements to increase. It is also true that the size is related to the operating frequency.

Since the filter is often the largest component of the multiplier, it is useful to know how many resonators are needed and how large your multiplier might be. MITEQ has engineering support available to help you get a feel for how large your multiplier might be. **Contact MITEQ at (631) 439-9220** to discuss the details about specifying the spurious rejection and size of your multiplier requirement for a cost-effective design.

ACTIVE FREQUENCY MULTIPLIERS

TYPICAL PERFORMANCE VS. INPUT POWER

INPUT RETURN LOSS VS. INPUT POWER FOR J DRIVE LEVEL MULTIPLIERS

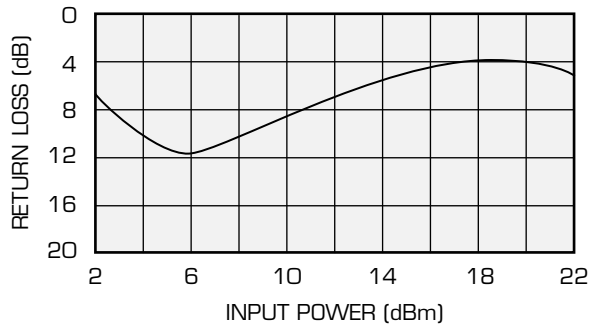

INPUT RETURN LOSS VS. INPUT POWER FOR M DRIVE LEVEL MULTIPLIERS

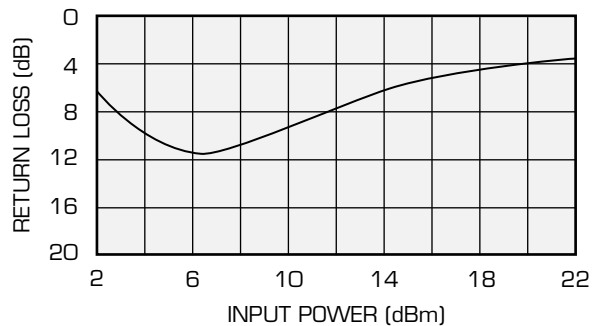

INPUT RETURN LOSS VS. INPUT POWER FOR V DRIVE LEVEL MULTIPLIERS

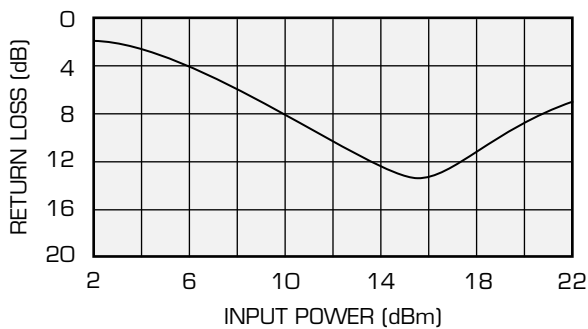

OUTPUT VS. INPUT POWER LEVEL FOR M AND V DRIVE LEVEL MULTIPLIERS

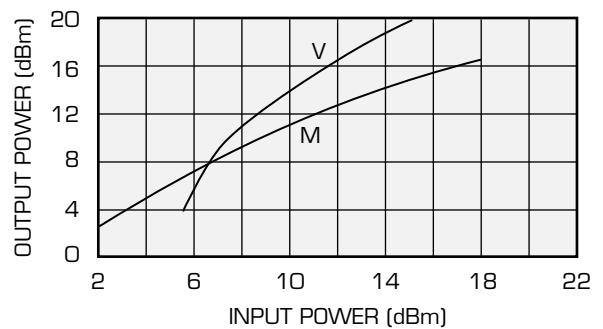

AVAILABLE INPUT POWER OPTIONS

DRIVE LEVEL	INPUT DRIVE (dBm)
J	3 – 8
M	8 – 12
H	12 – 16
V	16 – 20

COMMON APPLICATIONS

SATCOM PRODUCTS - COMMUNICATIONS RECEIVERS

Microwave front ends usually employ a phase-locked source, such as a frequency synthesizer which has extremely low phase-noise characteristics, especially for digital communications. The synthesizer uses a fundamental VCO which is locked to highly-stable crystal reference sources. The frequency limitation of many commercial VCOs and frequency dividers is 3500 MHz. A multiplier is employed to extend the synthesizer range.

RADAR RECEIVERS

Most radars employ frequency synthesizers which require frequency multipliers. The phase noise must be low to avoid clutter noise.

INSTRUMENTATION APPLICATIONS

Frequency synthesizers which require multipliers are found in the front end of many measuring instruments which require low phase-noise LOs. One example is a spectrum analyzer.

RADIO ASTRONOMY APPLICATIONS

Interferometers and radiometers require broadband frequency doublers for wideband receivers. Frequency synthesizers are used to generate millimeter-wave frequencies to make the measurements.

MILLIMETER-WAVE SOURCES

Millimeter-wave frequencies are used in research applications for atomic spectroscopy and for various communications and radars. A multiplier chain can be used to generate these frequencies from a lower frequency source.

FREQUENCY STANDARDS

Highly-stable frequency sources can be multiplied to produce microwave sources used to measure the effect of the atmosphere or rocket exhaust on microwave signals.

PASSIVE FREQUENCY DOUBLERS

MODEL NUMBER	INPUT FREQUENCY (GHz)	INPUT POWER (dBm)	OUTPUT FREQUENCY (GHz)	CONVERSION LOSS (dB) (Typ./Max.)	HARMONIC REJECTION FUND./ODD (dBc, Typ.)	OUTLINE NUMBER	PAGE
SUBOCTAVE BANDWIDTH							
MX2M260400*	13–20	8–12	26–40	10/13	-15	MXF	390
MX2V260400	13–20	16–20	26–40	10/13	-15	MXF	452
MX2M180500	9–25	10	18–50	15/17	-15	MXF	452
OCTAVE BANDWIDTH							
MX2J020040	1–2	3–8	2–4	9.5/15	-20	MX2A	451
MX2M020040*	1–2	8–12	2–4	9.5/13	-20	MX2A	391
MX2H020040	1–2	12–16	2–4	9.5/13	-20	MX2A	451
MX2V020040	1–2	16–20	2–4	9.5/13	-20	MX2A	451
MX2J040080-2C	2–4	3–8	4–8	11/15	-15/20	MX2C	452
MX2M040080-2C*	2–4	8–12	4–8	11/15	-15/20	MX2C	392
MX2H040080-2C	2–4	12–16	4–8	11/15	-15/20	MX2C	452
MX2V040080-2C	2–4	16–20	4–8	11/15	-15/20	MX2C	452
MX2J080160-2C	4–8	3–8	8–16	11/15	-15/20	MX2C	452
MX2M080160-2C*	4–8	8–12	8–16	11/15	-15/20	MX2C	393
MX2H080160-2C	4–8	12–16	8–16	11/15	-15/20	MX2C	452
MX2V080160-2C	4–8	16–20	8–16	11/15	-15/20	MX2C	452
MX2J130260	6.5–13	3–8	13–26	11/15	-15	MX2D	452
MX2M130260*	6.5–13	8–12	13–26	11/13	-15	MX2D	394
MX2H130260	6.5–13	12–16	13–26	11/13	-15	MX2D	452
MX2V130260	6.5–13	16–20	13–26	11/13	-15	MX2D	452
MX2M180400	9–20	10	18–40	12/14	-15	MXF	452
MX2M200400	10–20	10	20–40	12/14	-15	MXF	452
MULTIOCTAVE BANDWIDTH							
MX2J004010	0.02–0.5	3–8	0.04–1	10.5/13	-25	MX2A	451
MX2M004010*	0.02–0.5	8–12	0.04–1	10.5/13	-25	MX2A	395
MX2H004010	0.02–0.5	12–16	0.04–1	10.5/13	-25	MX2A	451
MX2V004010	0.02–0.5	16–20	0.04–1	10.5/13	-25	MX2A	451
MX2J010060	0.5–3	3–8	1–6	10.5/15	-15/20	MX2A	451
MX2M010060*	0.5–3	8–12	1–6	10.5/15	-15/20	MX2A	396
MX2H010060	0.5–3	12–16	1–6	10.5/15	-15/20	MX2A	451
MX2V010060	0.5–3	16–20	1–6	10.5/15	-15/20	MX2A	451
SXS2J010060	0.5–3	3–8	1–6	13/16	-20/25	160057	459
SXS2M010060*	0.5–3	8–12	1–6	13/16	-20/25	160057	397
SXS2H010060	0.5–3	12–16	1–6	13/16	-20/25	160057	459
SXS02J	0.5–3	3–8	1–6	13/16	-20/25	161565	460
SXS01M*	0.5–3	8–12	1–6	13/16	-20/25	161565	398
SXS03H	0.5–3	12–16	1–6	13/16	-20/25	161565	460
MX2J030180-2C	1.5–9	3–8	3–18	12/15	-15/20	MX2C	452
MX2M030180-2C*	1.5–9	8–12	3–18	12/15	-15/20	MX2C	399
MX2H030180-2C	1.5–9	12–16	3–18	12/15	-15/20	MX2C	452
MX2V030180-2C	1.5–9	16–20	3–18	12/15	-15/20	MX2C	452
SXS2J040180	2–9	3–8	4–18	13/15	-20/25	160057	459
SXS2M040180*	2–9	8–12	4–18	13/15	-20/25	160057	400
SXS2H040180	2–9	12–16	4–18	13/15	-20/25	160057	459
SXS05J	2–9	3–8	4–18	13/15	-20/25	161566	460
SXS04M*	2–9	8–12	4–18	13/15	-20/25	161566	401
SXS06H	2–9	12–16	4–18	13/15	-20/25	161566	460
MX2J060260	3–13	3–8	6–26	12/18	-15/20	MX2D	452
MX2M060260*	3–13	8–12	6–26	12/18	-15/20	MX2D	402
MX2H060260	3–13	12–16	6–26	12/18	-15/20	MX2D	452
MX2V060260	3–13	16–20	6–26	12/18	-15/20	MX2D	452

* Detailed specification sheet inside catalog.

PASSIVE FREQUENCY DOUBLERS (CONT.)

MODEL NUMBER	INPUT FREQUENCY (GHz)	INPUT POWER (dBm)	OUTPUT FREQUENCY (GHz)	CONVERSION LOSS (dB) (Typ./Max.)	HARMONIC REJECTION FUND./ODD (dBc, Typ.)	OUTLINE NUMBER	PAGE
MULTIOCTAVE BANDWIDTH (CONT.)							
SXS2J060260	3–13	3–8	6–26	13/18	-18/25	160057	459
SXS2M060260*	3–13	8–12	6–26	13/18	-18/25	160057	403
SXS2H060260	3–13	12–16	6–26	13/18	-18/25	160057	459
SXS08J	3–13	3–8	6–26	13/18	-18/25	163124	461
SXS07M*	3–13	8–12	6–26	13/18	-18/25	163124	404
SXS09H	3–13	12–16	6–26	13/18	-18/25	163124	461

* Detailed specification sheet inside catalog.
 NOTES: Custom bandwidths/rejection specs available. Please contact MITEQ.
 For higher-order passive multipliers, please contact MITEQ.

MODEL NUMBER	INPUT FREQUENCY (GHz)	INPUT POWER (dBm)	OUTPUT FREQUENCY (GHz)	CONVERSION LOSS (dB) (Typ./Max.)	HARMONIC REJECTION FUND./ODD (dBc, Typ.)	OUTLINE NUMBER	PAGE
TD0040LA2*	2–20	10–13	4–40	13/20	-15/20	120373	405

* Detailed specification sheet inside catalog.
 NOTES: Custom bandwidths/rejection specs available. Please contact MITEQ.
 For higher-order passive multipliers, please contact MITEQ.

ACTIVE FREQUENCY DOUBLERS

MODEL NUMBER	INPUT FREQUENCY (GHz)	INPUT POWER (dBm)	OUTPUT FREQUENCY (GHz)	OUTPUT POWER (dBm, Typ.)	CONVERSION GAIN (dB, Typ.)	HARMONIC REJECTION FUND./ODD (dBc, Typ.)	NOM. DC POWER (+15 V, mA)	OUTLINE NUMBER	NOTES	PAGE
SUBOCTAVE BANDWIDTH										
MAX2M180260	9-13	8-12	18-26	12-15	0-7	-20	175	MAX2K	1	455
MAX2P180260	9-13	-5+5	18-26	12-15	10-20	-20	250	MAX2M	1	456
MAX2M180260-20P	9-13	8-12	18-26	18-22	10-14	-20	375	MAX2L	1, 4	456
MAX2P180260-20P	9-13	-5+5	18-26	18-22	13-27	-20	450	MAX2N	1, 4	456
MAX2M260400*	13-20	8-12	26-40	12-15	0-7	-20	175	MAX2K	2	407
MAX2M260400W*	13-20	8-12	26-40	12-15	0-7	-20	175	MAX2G	2	408
MAX2M300500*	15-25	8-12	30-50	11-14	0-6	-20	175	MAX2K	3	409
MAX2M360500*	18-25	8-12	36-50	11-14	0-6	-20	175	MAX2K	3	410
MAX2M390440-20P*	19.5-22	8-12	39-44	18-22	10-14	-20	375	MAX2L	3, 4	411
MAX2M200380S	10-19	6-14	20-38	14-16	8-10	-20	200	MAX2M		456
OCTAVE BANDWIDTH										
MAX2J020040	1-2	3-8	2-4	3-8	0	-20	+5/100	MAX2A2		453
MAX2M020040*	1-2	8-12	2-4	8-12	0	-20	+5/100	MAX2A2		412
MAX2H020040	1-2	12-16	2-4	12-16	0	-20	+5/100	MAX2A		453
MAX2V020040	1-2	16-20	2-4	16-20	0	-20	+5/100	MAX2A		453
MAX2J040080	2-4	3-8	4-8	3-8	0	-20	+5/100	MAX2A2		453
MAX2M040080*	2-4	8-12	4-8	8-12	0	-20	+5/100	MAX2A2		413
MAX2H040080	2-4	12-16	4-8	12-16	0	-20	+5/100	MAX2B		453
MAX2V040080	2-4	16-20	4-8	16-20	0	-20	+5/100	MAX2B		453
SYS2J060120*	3-6	5	6-12	12	7	-20	+5/120	157637		414
SYS01J*	3-6	5	6-12	12	7	-20	+5/120	162011		415
SYS2H080160S	4-8	15	8-16	15	0	-20	150	157345		459
MAX2J080160	4-8	3-8	8-16	3-8	0	-20	125	MAX2B		453
MAX2M080160*	4-8	8-12	8-16	8-12	0	-20	125	MAX2B		416
MAX2H080160	4-8	12-16	8-16	12-16	0	-20	125	MAX2B		453
MAX2V080160	4-8	16-20	8-16	16-20	0	-20	125	MAX2B		453
SYS2J130260	6.5-13	3-8	13-26	3-8	0	-20	100	160833		460
SYS2M130260*	6.5-13	8-12	13-26	8-12	0	-20	100	160833		417
SYS2H130260	6.5-13	12-16	13-26	12-16	0	-20	100	160833		460
SYS2V130260	6.5-13	16-20	13-26	16-20	0	-20	350	160833		460
MAX2M180400	9-20	8-12	18-40	12-15	0-7	-20	175	MAX2K		455
MAX2P180400	9-20	-5+5	18-40	12-15	7-20	-20	275	MAX2M		456
MAX2M200400*	10-20	8-12	20-40	12-15	0-7	-20	175	MAX2K		418
MAX2P200400	10-20	-5+5	20-40	12-15	7-20	-20	175	MAX2M		456
MAX2M200400-20P*	10-20	8-12	20-40	18-22	6-14	-20	375	MAX2L	4	419
MAX2P200400-20P	10-20	-5+5	20-40	18-22	13-27	-20	475	MAX2N	4	456
MAX2M250500	12.5-25	10	25-50	10	2	-18	150	MAX2K		455
MULTIOCTAVE BANDWIDTH										
MAX2J010060	0.5-3	3-8	1-6	3-8	0	-20	+5/100	MAX2A2		453
MAX2M010060*	0.5-3	8-12	1-6	8-12	0	-20	+5/100	MAX2A2		420
MAX2H010060	0.5-3	12-16	1-6	12-16	0	-20	+5/100	MAX2A		453
MAX2V010060	0.5-3	16-20	1-6	16-20	0	-20	+5/100	MAX2A		453
MAX2J030180	1.5-9	3-8	3-18	3-8	0	-15/20	150	MAX2B		453
MAX2M030180*	1.5-9	8-12	3-18	8-12	0	-15/20	150	MAX2B		421
MAX2H030180	1.5-9	12-16	3-18	12-16	0	-15/20	150	MAX2B		453
MAX2V030180	1.5-9	16-20	3-18	16-20	0	-15/20	150	MAX2B		453
MAX2J060260	3-13	3-8	6-26	3-8	0	-12/15	210	MAX2C		454
MAX2M060260*	3-13	8-12	6-26	8-12	0	-12/15	210	MAX2C		422
MAX2H060260	3-13	12-16	6-26	12-16	0	-12/15	300	MAX2C		454
MAX2V060260	3-13	16-20	6-26	16-20	0	-12/15	350	MAX2C2		454
SYS2J150450*	7.5-22.5	3	15-45	+13	10	-20	220	163640	5	423

NOTES:

- (1) Available with WR42 on output.
 - (2) Available with WR28 on output.
 - (3) Available with WR22/WR19 on output.
 - (4) Requires negative bias -15 V at 70 mA.
 - (5) Requires negative bias -5 V at 50 mA.
- * Detailed specification sheet inside catalog.

SELECT BANDWIDTH DOUBLERS AND TRIPLERS

MODEL NUMBER	INPUT FREQUENCY (GHz)	INPUT POWER (dBm)	OUTPUT FREQUENCY (GHz)	OUTPUT POWER (dBm, Typ.)	HARMONIC SUPPRESSION (dBc, Typ.)	NOM. DC POWER (+15V, mA)	OUTLINE NUMBER	NOTE	PAGE
ACTIVE DOUBLERS WITH PRINTED FILTERS									
SYS2X1122*	9.5–11.5	-5	19–23	0	-50	250	**	1	424
SYS2X1326*	10–13.25	10-12	20–26.5	+16	-75	250	**	1	425
SYS2X2040*	10–20	9–13	20–40	+15	-16	250	**	1	426
SYS2X1224*	11.25–13.24	-5	22.48–26.48	+10	-70	250	**	1	427
SYS2X2640WG*	13–20	9–13	26–40	+15	-80	250	**	1	428
SYS2X1428*	14	12	28	+18	-70	180	**	1	429
SYS2X1530*	15	-20	30	+20	-90	450	**	1	430
SYS2X1734*	16–17.5	12	32–35	+18	-50	250	**	1	431
SYS2X1735*	17.5	-20	35	+18	-70	450	**	1	432

MODEL NUMBER	INPUT FREQUENCY (GHz)	INPUT POWER (dBm)	OUTPUT FREQUENCY (GHz)	OUTPUT POWER (dBm, Typ.)	HARMONIC SUPPRESSION (dBc, Typ.)	NOM. DC POWER (+15V, mA)	OUTLINE NUMBER	NOTE	PAGE
ACTIVE TRIPLERS WITH CARRIER OPTIONS									
SYS3J042072*	1.4–2.4	+4	4.2–7.2	+12	-20	+5/150	157637		433
SYS02J*	1.4–2.4	+4	4.2–7.2	+12	-20	+5/150	160212		434

MODEL NUMBER	INPUT FREQUENCY (GHz)	INPUT POWER (dBm)	OUTPUT FREQUENCY (GHz)	CONVERSION LOSS (dB, Typ./Max.)	HARMONIC SUPPRESSION (dBc, Typ.)	NOM. DC POWER (+15V, mA)	OUTLINE NUMBER	NOTE	PAGE
PASSIVE TRIPLERS ABOVE 26 GHz									
MX3M320400*	10.66–13.33	8–12	32–40	18/22	-55 (filtered)	N/A	MXF		435

MODEL NUMBER	INPUT FREQUENCY (GHz)	INPUT POWER (dBm)	OUTPUT FREQUENCY (GHz)	OUTPUT POWER (dBm, Typ.)	HARMONIC SUPPRESSION (dBc, Typ.)	NOM. DC POWER (+15V, mA)	OUTLINE NUMBER	NOTE	PAGE
ACTIVE TRIPLERS WITH PRINTED FILTERS									
SYS3X2327*	7.6–9	3	23–27	+10	-50	180	**	1	436
SYS3X3334*	11.1–11.6	15	33.3–34.8	+23	-80	320	**	1	437
SYS3X3550WG*	11.8–11.9	13	35.4–35.7	+14.5	-90	300	**	1	438
SYS3X3637*	12.2–12.5	13	36–37	+15	-60	200	**	1	439
SYS3X3738*	12.5–12.9	13	37–38	+16	-70	200	**	1	440
SYS3X3842*	12.6–14	12	38–42	+16	-70	200	**	1	441
SYS3X1442*	14	12	42	+12	-80	180	**	1	442

NOTES: The selected bandwidth designs on this page represent products that have built-in filtering for narrow bandwidth applications, and represent a cross section of the specialty multiplier products MITEQ has manufactured for specific situations in the commercial and military markets.

* Detailed specification sheet inside catalog.

** For outlines, see individual data pages.

(1) Requires negative bias -15 V nominal @ 20 mA maximum.

ACTIVE FREQUENCY TRIPLERS

MODEL NUMBER	INPUT FREQUENCY (GHz)	INPUT POWER (dBm)	OUTPUT FREQUENCY (GHz)	OUTPUT POWER (dBm, Typ.)	CONVERSION GAIN (dB, Typ.)	HARMONIC REJECTION IN/OUT (dBc, Min.)	POWER FLATNESS (±dB, Typ.)	VSWR IN/OUT (Typ.)	NOM. DC POWER (+5 V, mA)	OUTLINE NUMBER	PAGE
TRIPLERS – STANDARD BANDWIDTHS											
MAX3J045050	1.5–1.67	3–8	4.5–5	6–11	3	-60/-15	1	2:1/1.5:1	120	MAX3A	456
MAX3M045050	1.5–1.67	8–12	4.5–5	11–15	3	-60/-15	1	2:1/1.5:1	120	MAX3A	456
MAX3H045050	1.5–1.67	12–16	4.5–5	12–16	0	-60/-15	1	2:1/1.5:1	120	MAX3A	456
MAX3J050055	1.67–1.83	3–8	5–5.5	6–11	3	-60/-15	1	2:1/1.5:1	120	MAX3A	456
MAX3M050055	1.67–1.83	8–12	5–5.5	11–15	3	-60/-15	1	2:1/1.5:1	120	MAX3A	456
MAX3H050055	1.67–1.83	12–16	5–5.5	12–16	0	-60/-15	1	2:1/1.5:1	120	MAX3A	456
MAX3J055060	1.83–2	3–8	5.5–6	6–11	3	-60/-15	1	2:1/1.5:1	120	MAX3A	456
MAX3M055060	1.83–2	8–12	5.5–6	11–15	3	-60/-15	1	2:1/1.5:1	120	MAX3A	456
MAX3H055060	1.83–2	12–16	5.5–6	12–16	0	-60/-15	1	2:1/1.5:1	120	MAX3A	456
MAX3J060065	2–2.16	3–8	6–6.5	6–11	3	-60/-15	1	2:1/1.5:1	120	MAX3A	456
MAX3M060065	2–2.16	8–12	6–6.5	11–15	3	-60/-15	1	2:1/1.5:1	120	MAX3A	456
MAX3H060065	2–2.16	12–16	6–6.5	12–16	0	-60/-15	1	2:1/1.5:1	120	MAX3A	456
MAX3J065070	2.16–2.33	3–8	6.5–7	6–11	3	-60/-15	1	2:1/1.5:1	120	MAX3A	456
MAX3M065070	2.16–2.33	8–12	6.5–7	11–15	3	-60/-15	1	2:1/1.5:1	120	MAX3A	456
MAX3H065070	2.16–2.33	12–16	6.5–7	12–16	0	-60/-15	1	2:1/1.5:1	120	MAX3A	456
MAX3J070075	2.33–2.5	3–8	7–7.5	6–11	3	-60/-15	1	2:1/1.5:1	120	MAX3A	456
MAX3M070075	2.33–2.5	8–12	7–7.5	11–15	3	-60/-15	1	2:1/1.5:1	120	MAX3A	456
MAX3H070075	2.33–2.5	12–16	7–7.5	12–16	0	-60/-15	1	2:1/1.5:1	120	MAX3A	456
MAX3J075080	2.5–2.66	3–8	7.5–8	6–11	3	-60/-15	1	2:1/1.5:1	120	MAX3A	456
MAX3M075080	2.5–2.66	8–12	7.5–8	11–15	3	-60/-15	1	2:1/1.5:1	120	MAX3A	456
MAX3H075080	2.5–2.66	12–16	7.5–8	12–16	0	-60/-15	1	2:1/1.5:1	120	MAX3A	456
MAX3J080085	2.66–2.83	3–8	8–8.5	6–11	3	-60/-15	1	2:1/1.5:1	120	MAX3A	456
MAX3M080085	2.66–2.83	8–12	8–8.5	11–15	3	-60/-15	1	2:1/1.5:1	120	MAX3A	456
MAX3H080085	2.66–2.83	12–16	8–8.5	12–16	0	-60/-15	1	2:1/1.5:1	120	MAX3A	456
MAX3J043052	1.43–1.73	3–8	4.3–5.2	6–11	3	-60/-15	1	2:1/1.5:1	120	MAX3A	456
MAX3M043052	1.43–1.73	8–12	4.3–5.2	11–15	3	-60/-15	1	2:1/1.5:1	120	MAX3A	456
MAX3H043052	1.43–1.73	12–16	4.3–5.2	12–16	0	-60/-15	1	2:1/1.5:1	120	MAX3A	456
TRIPLERS – WIDE BANDWIDTHS											
MAX3J047056	1.56–1.86	3–8	4.7–5.6	6–11	3	-60/-15	1	2:1/1.5:1	120	MAX3A	456
MAX3M047056	1.56–1.86	8–12	4.7–5.6	11–15	3	-60/-15	1	2:1/1.5:1	120	MAX3A	456
MAX3H047056	1.56–1.86	12–16	4.7–5.6	12–16	0	-60/-15	1	2:1/1.5:1	120	MAX3A	456
MAX3J063074	2.1–2.46	3–8	6.3–7.4	6–11	3	-60/-15	1	2:1/1.5:1	120	MAX3A	456
MAX3M063074	2.1–2.46	8–12	6.3–7.4	11–15	3	-60/-15	1	2:1/1.5:1	120	MAX3A	456
MAX3H063074	2.1–2.46	12–16	6.3–7.4	12–16	0	-60/-15	1	2:1/1.5:1	120	MAX3A	456
MAX3J070083	2.3–2.76	3–8	7–8.3	6–11	3	-60/-15	1	2:1/1.5:1	120	MAX3A	456
MAX3M070083	2.3–2.76	8–12	7–8.3	11–15	3	-60/-15	1	2:1/1.5:1	120	MAX3A	456
MAX3H070083	2.3–2.76	12–16	7–8.3	12–16	0	-60/-15	1	2:1/1.5:1	120	MAX3A	456
MAX3M154172	5.150–5.740	13	15.450–17.220	13	0	-60/-15	1	2:1/1.5:1	150*	**	456
MAX3M172190	5.740–6.330	13	17.220–18.990	13	0	-60/-15	1	2:1/1.5:1	150*	**	456
MAX3M300300	10	10–15	30	10–13	0	-18	–	3:1/2:1	160*	MAX2M	456
MAX3M260400	8.66–13.33	10	26–40	13–16	3–6	-18	–	3:1/2:1	160	MAX2M	456
MAX3M300500	10–16.666	10	30–50	10–13	0–3	-20	2	3:1/2:1	160	MAX2K	455

* Nominal current at +15 VDC.

** Consult MITEQ for specific packaging information.

NOTE: MAX3 Series multipliers below 26 GHz have tunable comb filters. MITEQ can adjust these up and down to meet other frequency plans.

HIGHER ORDER ACTIVE MULTIPLIERS

MODEL NUMBER	INPUT FREQUENCY (GHz)	INPUT POWER (dBm)	OUTPUT FREQUENCY (GHz)	OUTPUT POWER (dBm, Typ.)	CONVERSION GAIN (dB, Typ.)	HARMONIC REJECTION IN/OUT (dBc, Min.)	POWER FLATNESS (±dB, Typ.)	VSWR IN/OUT (Typ.)	NOM. DC POWER (+15 V, mA)	OUTLINE NUMBER	PAGE
QUADRUPLERS											
MAX4J050055	1.25–1.375	3–8	5–5.5	6–11	3	-50/-15	1	2:1/1.5:1	150	MAX4A	457
MAX4M050055*	1.25–1.375	8–12	5–5.5	11–15	3	-50/-15	1	2:1/1.5:1	150	MAX4A	449
MAX4H050055	1.25–1.375	12–16	5–5.5	12–16	0	-50/-15	1	2:1/1.5:1	150	MAX4A	457
MAX4J055060	1.375–1.5	3–8	5.5–6	6–11	3	-50/-15	1	2:1/1.5:1	150	MAX4A	457
MAX4M055060	1.375–1.5	8–12	5.5–6	11–15	3	-50/-15	1	2:1/1.5:1	150	MAX4A	457
MAX4H055060	1.375–1.5	12–16	5.5–6	12–16	0	-50/-15	1	2:1/1.5:1	150	MAX4A	457
MAX4J060065	1.5–1.625	3–8	6–6.5	6–11	3	-50/-15	1	2:1/1.5:1	150	MAX4A	457
MAX4M060065	1.5–1.625	8–12	6–6.5	11–15	3	-50/-15	1	2:1/1.5:1	150	MAX4A	457
MAX4H060065	1.5–1.625	12–16	6–6.5	12–16	0	-50/-15	1	2:1/1.5:1	150	MAX4A	457
MAX4M062071*	1.55–1.78	8–12	6.2–7.1	11–15	3	-50/-15	2	2:1/1.5:1	150	MAX4A	449
MAX4J065070	1.625–1.75	3–8	6.5–7	6–11	3	-50/-15	1	2:1/1.5:1	150	MAX4A	457
MAX4M065070	1.625–1.75	8–12	6.5–7	11–15	3	-50/-15	1	2:1/1.5:1	150	MAX4A	457
MAX4H065070	1.625–1.75	12–16	6.5–7	12–16	0	-50/-15	1	2:1/1.5:1	150	MAX4A	457
MAX4J070075	1.75–1.875	3–8	7–7.5	6–11	3	-50/-15	1	2:1/1.5:1	150	MAX4A	457
MAX4M070075	1.75–1.875	8–12	7–7.5	11–15	3	-50/-15	1	2:1/1.5:1	150	MAX4A	457
MAX4H070075	1.75–1.875	12–16	7–7.5	12–16	0	-50/-15	1	2:1/1.5:1	150	MAX4A	457
MAX4V168176-23P	4.2–4.4	17	16.8–17.6	23	6	-60/-15	1.5	2:1/1.5:1	400	**	-
MAX4M400480*	10–12	10–15	40–48	8–11	0	-18	2	3:1/2.5:1	150	MAX2H	449
MAX4M380460	9.5–11.5	8–12	38–46	10–13	2	-18	2	3:1/2.5:1	180	MAX2M	456
MAX4M360480	9–12	8–12	36–48	10–13	2	-18	2	3:1/2.5:1	180	MAX2M	456
MAX4M360500	9–12.5	8–12	36–50	10–13	2	-18	2	3:1/2.5:1	180	MAX2M	456
SYS4X1146*	10.25–11.5	12	41–46	12	0	-60	2	2.5:1/2.75:1	180	**	443

* Detailed specification sheet inside catalog.
 ** Please contact MITEQ for specific packaging information.

NOTE: MAX4 Series multipliers below 26 GHz have tunable comb filters. MITEQ can adjust these up and down to meet other frequency plans.

HIGHER-ORDER ACTIVE MULTIPLIERS (CONT.)

MODEL NUMBER	INPUT FREQUENCY (GHz)	OUTPUT FREQUENCY (GHz)	INPUT/OUTPUT POWER (dBm)	CONVERSION GAIN (dB, Typ.)	VOLTAGE CURRENT (+5, -2.5, mA)	HARMONIC REJECTION IN/OUT (dBc, Min.)	POWER FLATNESS (±dB, Typ.)	VSWR IN/OUT (Typ.)	OUTLINE NUMBER	PAGE
LOW COST DOUBLERS WITH PRINTED FILTERS										
MAX2M045055	2.25–2.78	4.5–5.58	8–10	0	+5/120**	-65/-15	1.5	2:1	MAX2D	454
MAX2M055059	2.75–2.94	5.51–5.59	8–10	0	+5/120**	-65/-15	1.5	2:1	MAX2D	454
MAX4M088095	2.2–2.37	8.88–9.48	8–10	0	120	-65/-15	1.5	2:1	MAX4B	457
MAX4M109115	2.73–2.88	10.91–11.53	8–10	0	120	-65/-15	1.5	2:1	MAX4B	457
MAX4M114120	2.86–3.01	11.46–12.03	8–10	0	120	-65/-15	1.5	2:1	MAX4B	457
MAX4M114126	2.86–3.14	11.46–12.57	8–10	0	120	-65/-15	1.5	2:1	MAX4B	457
MAX4M124133	3.11–3.32	12.46–13.28	8–10	0	120	-65/-15	1.5	2:1	MAX4B	457
MAX4M127134*	3.17–3.32	12.71–13.3	8–10	0	120	-65/-15	1.5	2:1	MAX4B	450
MAX4M127148	3.18–3.85	12.72–14.84	8–10	0	120	-65/-15	1.5	2:1	MAX4C	457
MAX4M129138	3.24–3.45	12.97–13.79	8–10	0	120	-65/-15	1.5	2:1	MAX4B	457
MAX4M139144	3.48–3.61	13.95–14.46	8–10	0	120	-65/-15	1.5	2:1	MAX4C	457
MAX4M144146	3.61–3.65	14.4–14.66	8–10	0	120	-65/-15	1.5	2:1	MAX4C	457
MAX4M145154	3.62–4.22	14.5–15.4	8–10	0	120	-65/-15	1.5	2:1	MAX4C	457
MAX4M150162	3.75–4.05	15–16.17	8–10	0	120	-65/-15	1.5	2:1	MAX4C	457
MAX4M152163	3.8–4.08	15.21–16.31	8–10	0	120	-65/-15	1.5	2:1	MAX4C	457
MAX4M160169	4–4.22	16–16.9	8–10	0	120	-65/-15	1.5	2:1	MAX4C	457

* Detailed specification sheet inside catalog. Data taken with +12 dBm drive.
 ** No negative voltage required for this product.
 NOTES: These multipliers are designed with printed filters, and for lower cost than tunable products. The frequency plans can be easily changed with slight filter modifications.

MODEL NUMBER	INPUT FREQUENCY (GHz)	OUTPUT FREQUENCY (GHz)	INPUT/OUTPUT POWER (dBm)	CONVERSION GAIN (dB, Typ.)	VOLTAGE CURRENT (+5, -2.5, mA)	HARMONIC REJECTION IN/OUT (dB)	POWER FLATNESS (±dB, Typ.)	VSWR IN/OUT (Typ.)	COUPLED PORT PWR RANGE (dB)*	OUTLINE NUMBER	PAGE
LOW COST DOUBLERS AND QUADRUPLERS WITH MONITOR PORTS											
MAX2M045055-C	2.25–2.78	4.5–5.58	8–10	0	+5/120**	-65/-15	1.5	2:1	-17 to -23	MAX2E	454
MAX2M055059-C	2.75–2.94	5.51–5.59	8–10	0	+5/120**	-65/-15	1.5	2:1	-17 to -23	MAX2E	454
MAX4M104110-C	2.6–2.75	10.4–11	8–10	0	120	-65/-15	1.5	2:1	-17 to -23	MAX4D	457
MAX4M114126-C	2.86–3.14	11.46–12.57	8–10	0	120	-65/-15	1.5	2:1	-17 to -23	MAX4D	457
MAX4M127148-C	3.18–3.85	12.72–14.84	8–10	0	120	-65/-15	1.5	2:1	-17 to -23	MAX4E	458
MAX4M150162-C	3.75–4.05	15–16.17	8–10	0	120	-65/-15	1.5	2:1	-17 to -23	MAX4E	458

* Used to monitor main port.
 ** No negative voltage required for this product.
 NOTES: These multipliers are designed with an additional coupler.
 In certain applications, there could be a need to monitor the output for an alarm, should the source fail.

HIGHER ORDER ACTIVE MULTIPLIERS (CONT.)

MODEL NUMBER	INPUT FREQUENCY (GHz)	INPUT POWER (dBm)	OUTPUT FREQUENCY (GHz)	OUTPUT POWER (dBm, Typ.)	CONVERSION GAIN (dB, Typ.)	HARMONIC REJECTION IN/OUT (dBc, Min.)	POWER FLATNESS (±dB, Typ.)	VSWR IN/OUT (Typ.)	NOM. DC POWER (+15 V, mA)	OUTLINE NUMBER	PAGE
QUINTUPLERS											
MAX5J085090	1.7–1.8	3–8	8.5–9	6–11	3	-60/-15	1	2:1/1.5:1	150	MAX5A	458
MAX5M085090	1.7–1.8	8–12	8.5–9	11–15	3	-60/-15	1	2:1/1.5:1	150	MAX5A	458
MAX5H085090	1.7–1.8	12–16	8.5–9	12–16	0	-60/-15	1	2:1/1.5:1	150	MAX5A	458
MAX5J090095	1.8–1.9	3–8	9–9.5	6–11	3	-60/-15	1	2:1/1.5:1	150	MAX5A	458
MAX5M090095	1.8–1.9	8–12	9–9.5	11–15	3	-60/-15	1	2:1/1.5:1	150	MAX5A	458
MAX5H090095	1.8–1.9	12–16	9–9.5	12–16	0	-60/-15	1	2:1/1.5:1	150	MAX5A	458
MAX5J095105	1.9–2.1	3–8	9.5–10.5	6–11	3	-60/-15	1	2:1/1.5:1	150	MAX5A	458
MAX5M095105	1.9–2.1	8–12	9.5–10.5	11–15	3	-60/-15	1	2:1/1.5:1	150	MAX5A	458
MAX5H095105	1.9–2.1	12–16	9.5–10.5	12–16	0	-60/-15	1	2:1/1.5:1	150	MAX5A	458
MAX5J105115	2.1–2.3	3–8	10.5–11.5	6–11	3	-60/-15	1	2:1/1.5:1	150	MAX5A	458
MAX5M105115	2.1–2.3	8–12	10.5–11.5	11–15	3	-60/-15	1	2:1/1.5:1	150	MAX5A	458
MAX5H105115	2.1–2.3	12–16	10.5–11.5	12–16	0	-60/-15	1	2:1/1.5:1	150	MAX5A	458
MAX5J115125	2.3–2.5	3–8	11.5–12.5	6–11	3	-60/-15	1	2:1/1.5:1	150	MAX5A	458
MAX5M115125	2.3–2.5	8–12	11.5–12.5	11–15	3	-60/-15	1	2:1/1.5:1	150	MAX5A	458
MAX5H115125	2.3–2.5	12–16	11.5–12.5	12–16	0	-60/-15	1	2:1/1.5:1	150	MAX5A	458
MAX5J125135	2.5–2.7	3–8	12.5–13.5	6–11	3	-60/-15	1	2:1/1.5:1	150	MAX5A	458
MAX5M125135	2.5–2.7	8–12	12.5–13.5	11–15	3	-60/-15	1	2:1/1.5:1	150	MAX5A	458
MAX5H125135	2.5–2.7	12–16	12.5–13.5	12–16	0	-60/-15	1	2:1/1.5:1	150	MAX5A	458
MAX5J135145	2.7–2.9	3–8	13.5–14.5	6–11	3	-60/-15	1	2:1/1.5:1	150	MAX5A	458
MAX5M135145	2.7–2.9	8–12	13.5–14.5	11–15	3	-60/-15	1	2:1/1.5:1	150	MAX5A	458
MAX5H135145	2.7–2.9	12–16	13.5–14.5	12–16	0	-60/-15	1	2:1/1.5:1	150	MAX5A	458
MAX5J114127	2.28–2.56	3–8	11.4–12.8	6–11	3	-60/-15	1	2:1/1.5:1	150	MAX5A	458
MAX5M114127	2.28–2.56	8–12	11.4–12.8	11–15	3	-60/-15	1	2:1/1.5:1	150	MAX5A	458
MAX5H114127	2.28–2.56	12–16	11.4–12.8	12–16	0	-60/-15	1	2:1/1.5:1	150	MAX5A	458
MAX5J127142	2.54–2.84	3–8	12.7–14.2	6–11	3	-60/-15	1	2:1/1.5:1	150	MAX5A	458
MAX5M127142	2.54–2.84	8–12	12.7–14.2	11–15	3	-60/-15	1	2:1/1.5:1	150	MAX5A	458
MAX5H127142	2.54–2.84	12–16	12.7–14.2	12–16	0	-60/-15	1	2:1/1.5:1	150	MAX5A	458
SYS5J100100*	2	10	10	10	0	-70	N/A	2.5:1/2:1	250	149228	444

* Detailed specification sheet inside catalog.
NOTE: MAX5 Series multipliers have tunable comb filters. MITEQ can adjust these up and down to meet other frequency plans.

OTHER HIGHER ORDER DESIGNS

MODEL NUMBER	INPUT FREQUENCY (MHz)	INPUT POWER (dBm)	OUTPUT FREQUENCY (GHz)	CONVERSION LOSS (dB, Typ.)	HARMONIC SUPPRESSION (dBc, Typ.)	NOM. DC POWER (+15V, mA)	OUTLINE NUMBER	PAGE
OTHER HIGHER ORDER DESIGNS								
SYS20M028032*	142–158	10–13	2.85–3.15	-10	-55	170	**	445
COMB MULTIPLIER DESIGNS								
EOM0218HW4*	500–150	7–13	2–18	17(X2) 18(X4) 24(X9) 33(X12)	N/A	115	**	447

* Detailed specification sheet inside catalog.
** For outlines, see individual data pages.

PASSIVE FREQUENCY DOUBLERS

MODEL: MX2M260400

ELECTRICAL SPECIFICATIONS

Input frequency range	13 – 20 GHz
Output frequency range	26 – 40 GHz
Input power range	8 – 12 dBm nominal
Conversion loss	10 dB typical 13 dB maximum
Harmonic rejection	
Fundamental	15 dB typical
Odd harmonic	15 dB typical

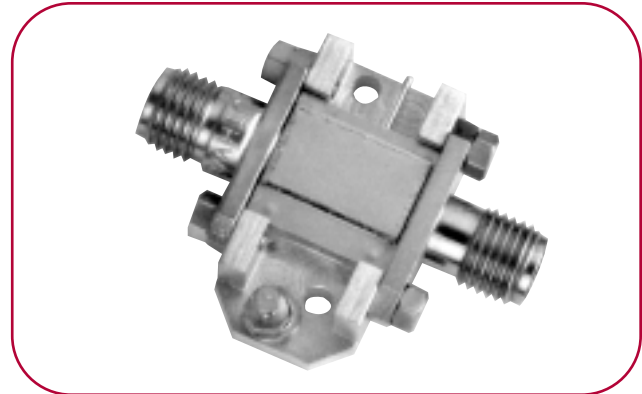

CONVERSION LOSS VS. FREQUENCY

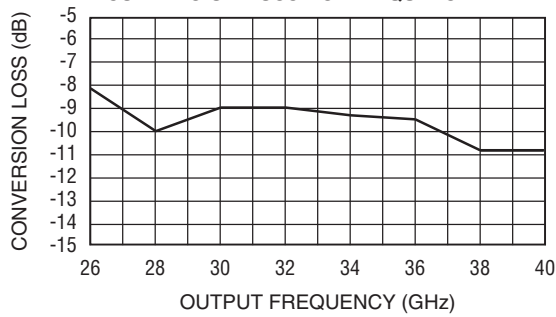

FUNDAMENTAL HARMONIC REJECTION VS. FREQUENCY

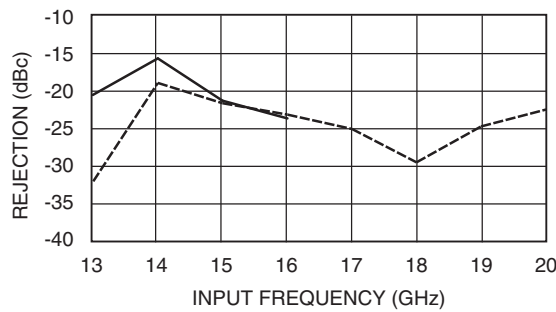

OUTPUT POWER VS. INPUT POWER ($P_{IN} = +10$ dBm)

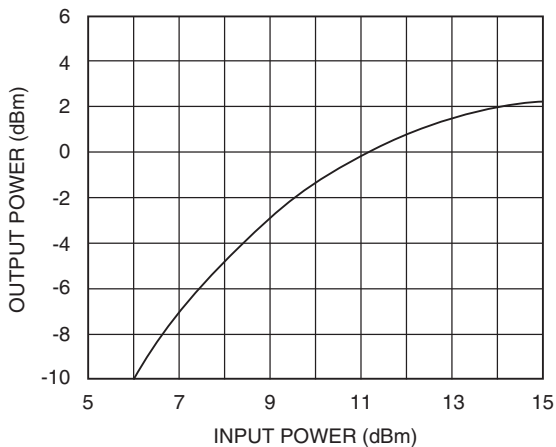

OUTLINE DRAWING

MXF

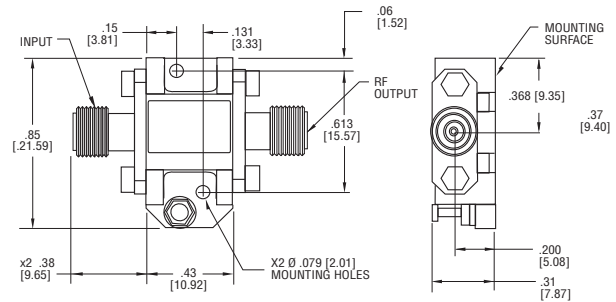

NOTES:

- Optional SMA, K type male connectors in input, K or V type male connectors in output.
- All dimensions shown in brackets [] are in millimeters.

PASSIVE FREQUENCY DOUBLERS (CONT.)

MODEL: MX2M020040

ELECTRICAL SPECIFICATIONS

Input frequency range	1 – 2 GHz minimum
Output frequency range	2 – 4 GHz minimum
Input power range	8 – 12 dBm nominal
Conversion loss	9.5 dB typical 13 dB maximum
Optional input power	
MX2J020040	3–8 dBm
MX2H020040	12–16 dBm
MX2V020040	16–20 dBm
Harmonic rejection	
Fundamental	20 dB typical
Odd harmonic	20 dB typical



CONVERSION LOSS VS. FREQUENCY

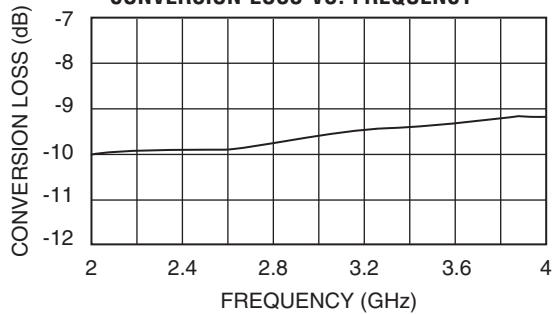

FUNDAMENTAL REJECTION VS. FREQUENCY

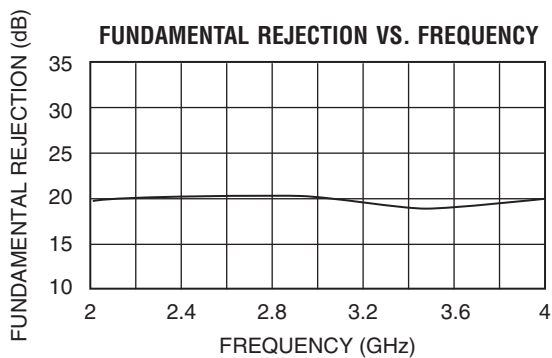

OUTPUT POWER VS. INPUT POWER ($P_{IN} = +10$ dBm)

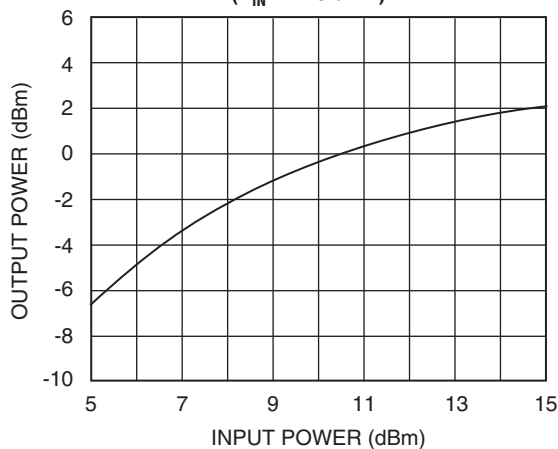

OUTLINE DRAWING

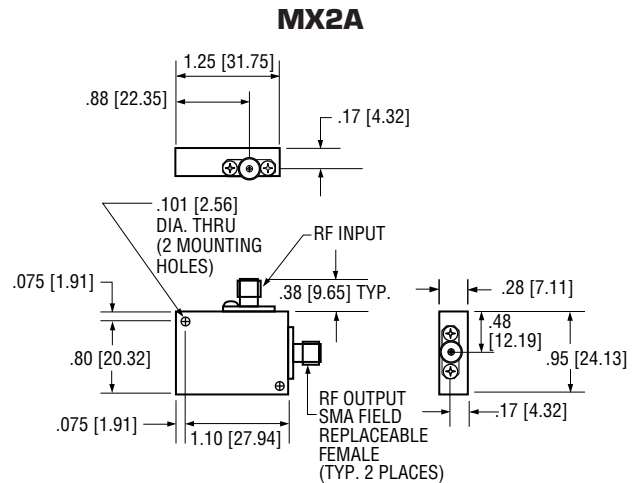

NOTE:

1. All dimensions shown in brackets [] are in millimeters.

PASSIVE FREQUENCY DOUBLERS (CONT.)

MODEL: MX2M040080-2C

ELECTRICAL SPECIFICATIONS

Input frequency range	2 – 4 GHz minimum
Output frequency range	4 – 8 GHz minimum
Input power range	8 – 12 dBm nominal
Conversion loss	11 dB typical 13 dB maximum
Optional input power	
MX2J040080-2C	3–8 dBm
MX2H040080-2C	12–16 dBm
MX2V040080-2C	16–20 dBm
Harmonic rejection	
Fundamental	20 dB typical
Odd harmonic	20 dB typical

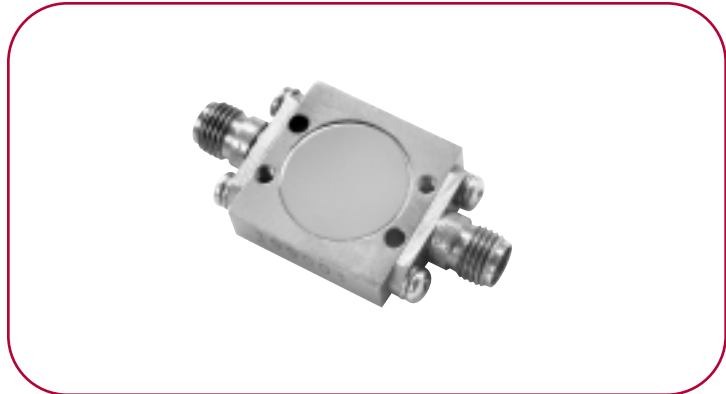

CONVERSION LOSS VS. FREQUENCY

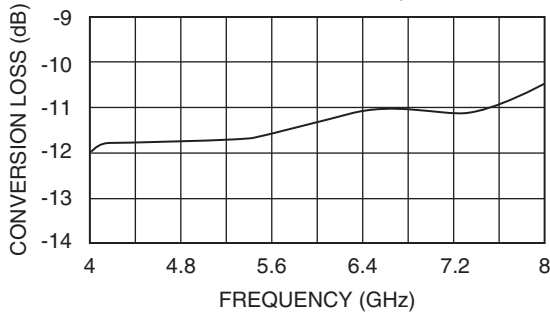

FUNDAMENTAL REJECTION VS. FREQUENCY

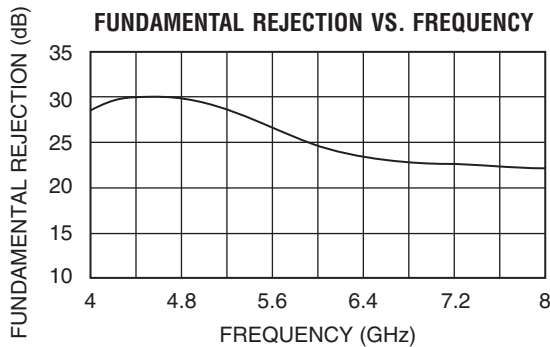

OUTPUT POWER VS. INPUT POWER ($P_{IN} = +10$ dBm)

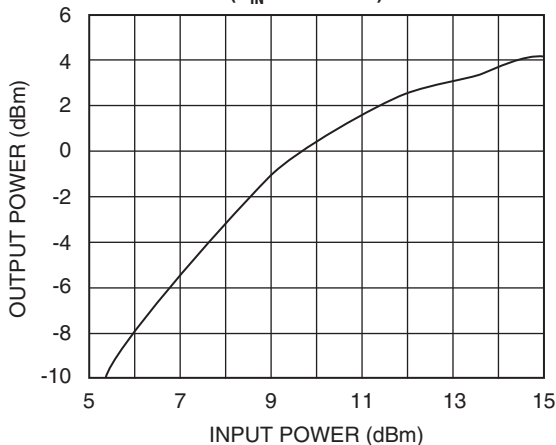

OUTLINE DRAWING

MX2C

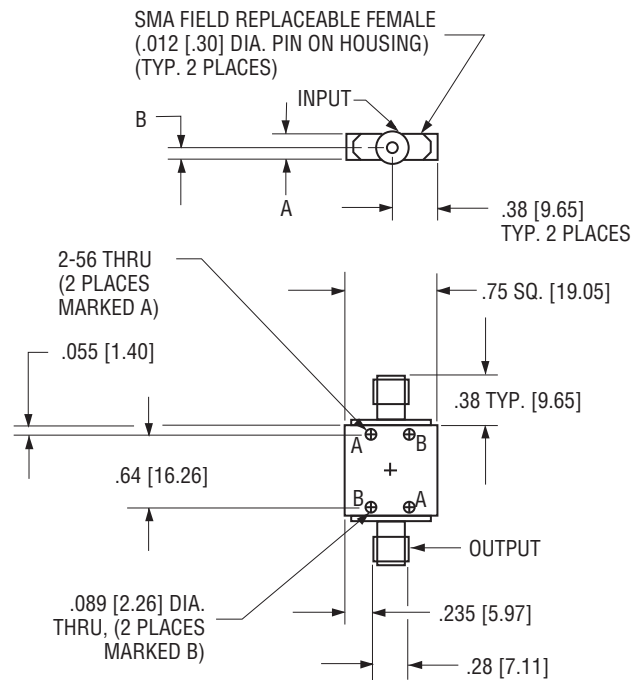

OUTLINE DASH NO.	DIM A	DIM B
-1	.226 [5.74]	.121 [3.07]

NOTE:
1. All dimensions shown in brackets [] are in millimeters.

PASSIVE FREQUENCY DOUBLERS (CONT.)

MODEL: MX2M080160-2C

ELECTRICAL SPECIFICATIONS

Input frequency range	4 – 8 GHz minimum
Output frequency range	8 – 16 GHz minimum
Input power range	8 – 12 dBm nominal
Conversion loss	11 dB typical 13 dB maximum
Optional input power	
MX2J080160-2C	3–8 dBm
MX2H080160-2C	12–16 dBm
MX2V080160-2C	16–20 dBm
Harmonic rejection	
Fundamental	20 dB typical
Odd harmonic	20 dB typical

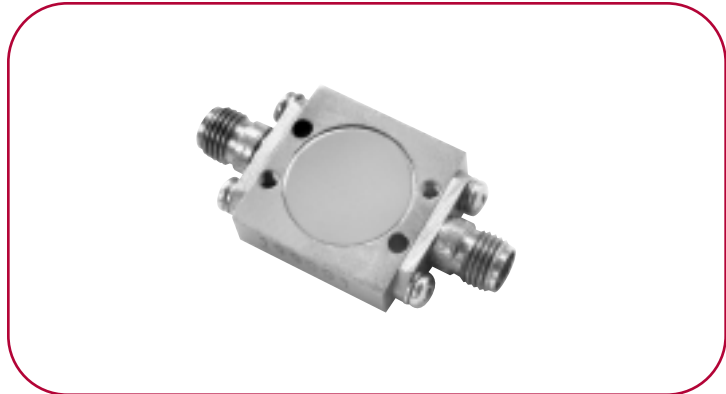

CONVERSION LOSS VS. FREQUENCY

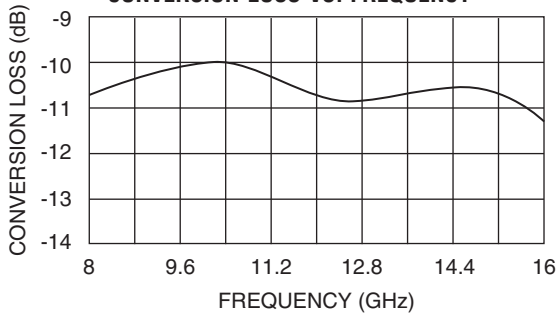

FUNDAMENTAL REJECTION VS. FREQUENCY

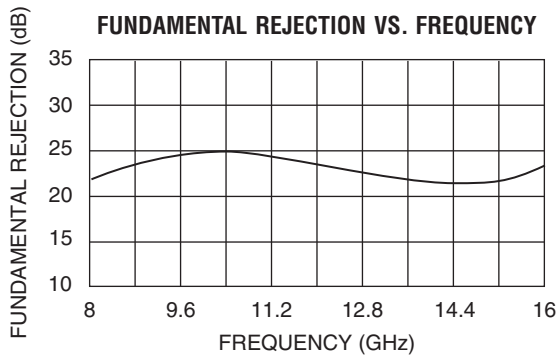

OUTPUT POWER VS. INPUT POWER ($P_{IN} = +10$ dBm)

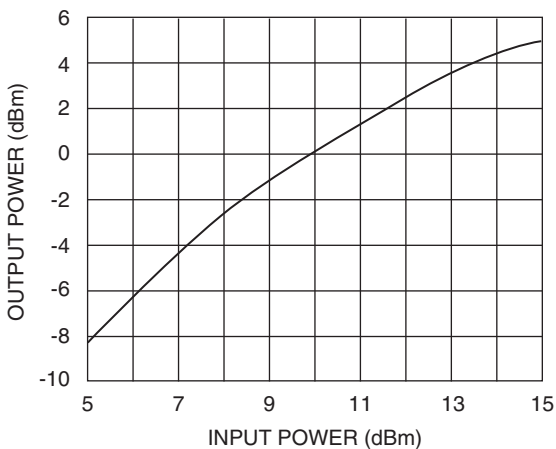

OUTLINE DRAWING

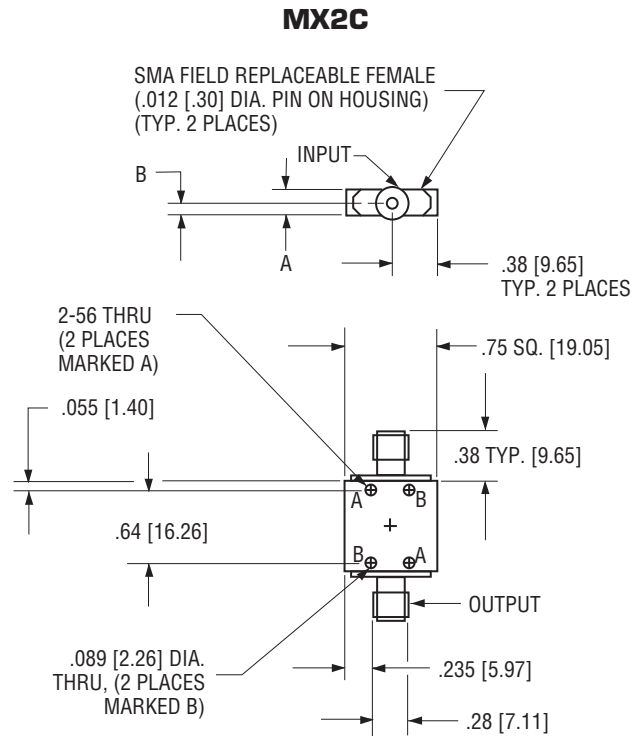

OUTLINE
DASH NO.

DIM A

DIM B

-1

.226 [5.74]

.121 [3.07]

NOTE:

1. All dimensions shown in brackets [] are in millimeters.

PASSIVE FREQUENCY DOUBLERS (CONT.)

MODEL: MX2M130260

ELECTRICAL SPECIFICATIONS

Input frequency range	6.5 – 13 GHz minimum
Output frequency range	13 – 26 GHz minimum
Input power range	8 – 12 dBm nominal
Conversion loss	11 dB typical 13 dB maximum
Optional input power	
MX2J130260	3–8 dBm
MX2H130260	12–16 dBm
MX2V130260	16–20 dBm
Harmonic rejection	
Fundamental	15 dB typical
Odd harmonic	15 dB typical

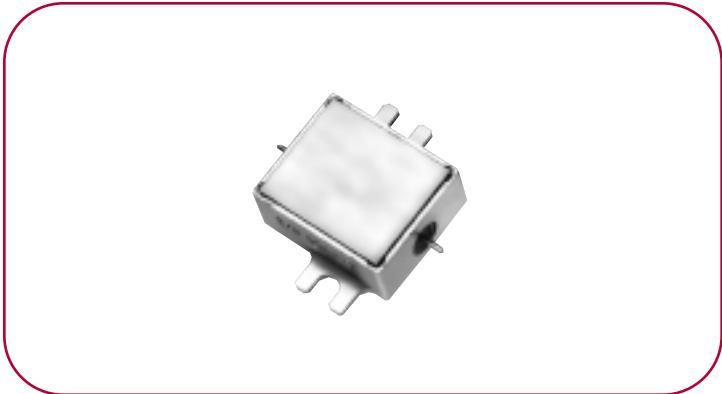

CONVERSION LOSS VS. FREQUENCY

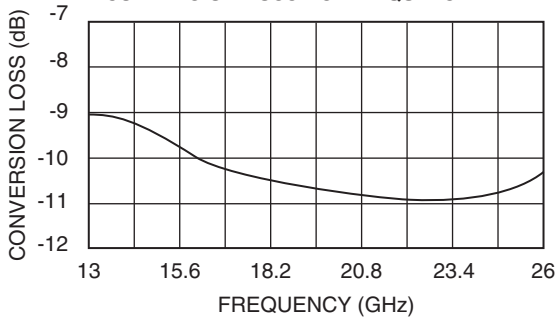

FUNDAMENTAL REJECTION VS. FREQUENCY

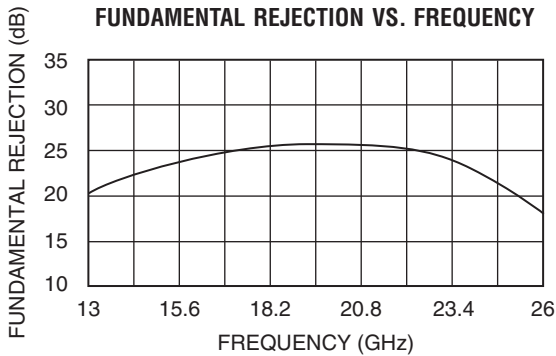

OUTPUT POWER VS. INPUT POWER ($P_{IN} = +10$ dBm)

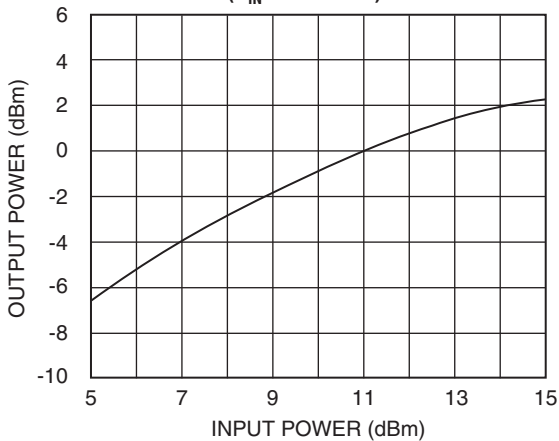

OUTLINE DRAWING

MX2D

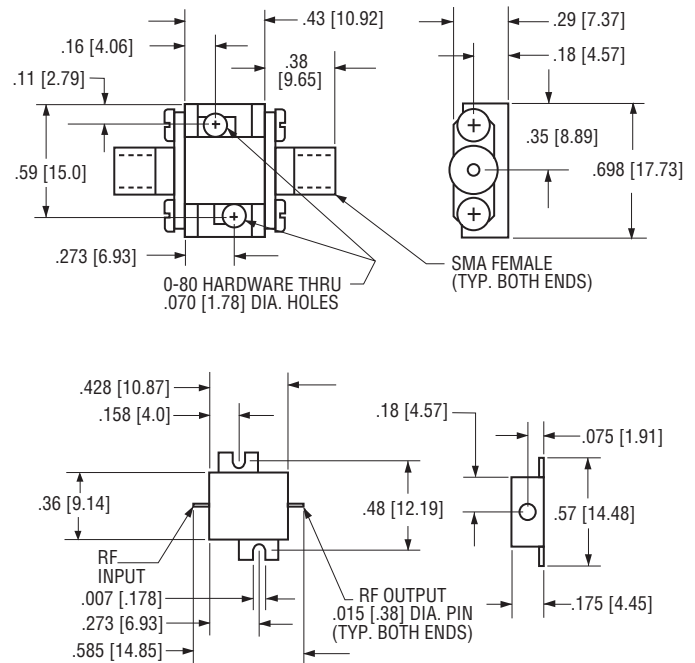

NOTES:

1. Doubler may be readily used as is, or as a drop-in by removing the SMA connectors and mounting hardware as shown.
2. All dimensions shown in brackets [] are in millimeters.

PASSIVE FREQUENCY DOUBLERS (CONT.)

MODEL: MX2M004010

ELECTRICAL SPECIFICATIONS

Input frequency range	0.02 – 0.5 GHz minimum
Output frequency range	0.04 – 1 GHz minimum
Input power range	8 – 12 dBm nominal
Conversion loss	10.5 dB typical 13 dB maximum
Optional input power	
MX2J004010	3–8 dBm
MX2H004010	12–16 dBm
MX2V004010	16–20 dBm
Harmonic rejection	
Fundamental	25 dB typical
Odd harmonic	25 dB typical



CONVERSION LOSS VS. FREQUENCY

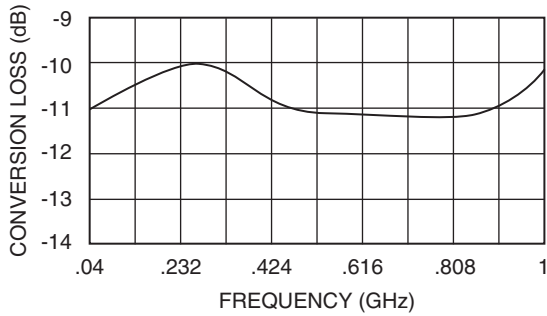

FUNDAMENTAL REJECTION VS. FREQUENCY

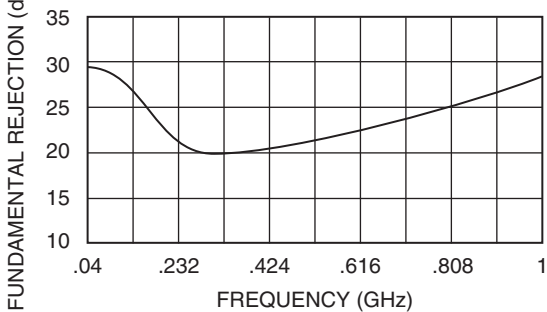

OUTPUT POWER VS. INPUT POWER ($P_{IN} = +10$ dBm)

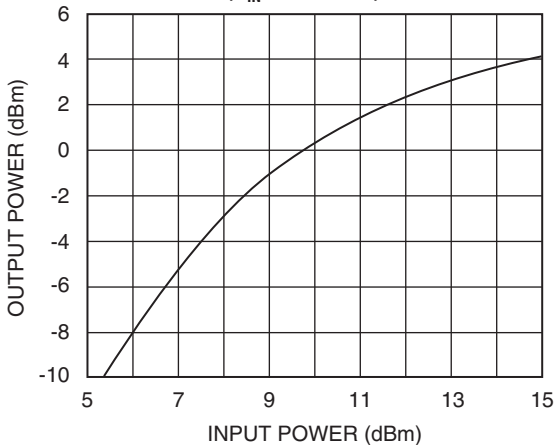

OUTLINE DRAWING

MX2A

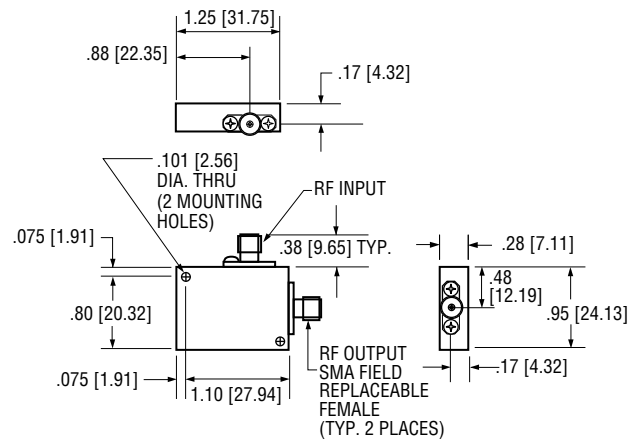

NOTE:

1. All dimensions shown in brackets [] are in millimeters.

PASSIVE FREQUENCY DOUBLERS (CONT.)

MODEL: MX2M010060

ELECTRICAL SPECIFICATIONS

Input frequency range	0.5 – 3 GHz minimum
Output frequency range	1 – 6 GHz minimum
Input power range	8 – 12 dBm nominal
Conversion loss	10.5 dB typical 15 dB maximum
Optional input power	
MX2J010060	3–8 dBm
MX2H010060	12–16 dBm
MX2V010060	16–20 dBm
Harmonic rejection	
Fundamental	15 dB typical
Odd harmonic	20 dB typical



CONVERSION LOSS VS. FREQUENCY

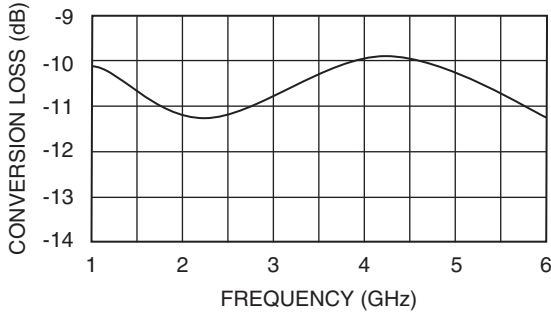

FUNDAMENTAL REJECTION VS. FREQUENCY

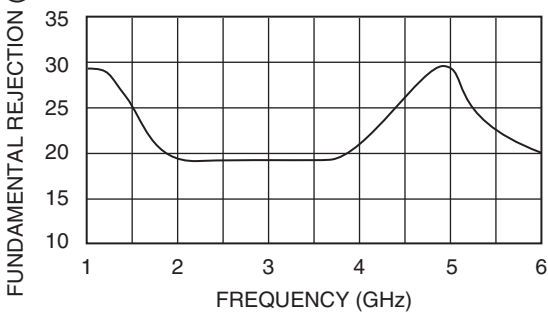

OUTPUT POWER VS. INPUT POWER ($P_{IN} = +10$ dBm)

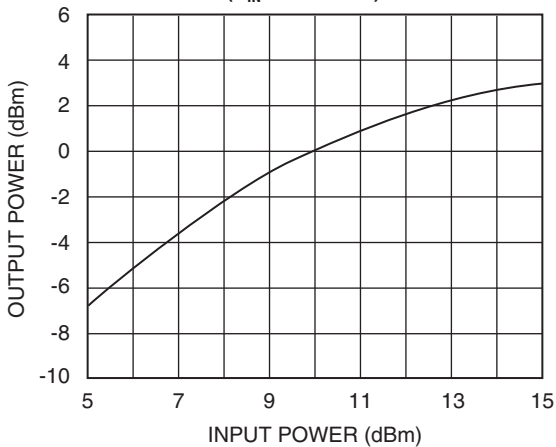

OUTLINE DRAWING

MX2A

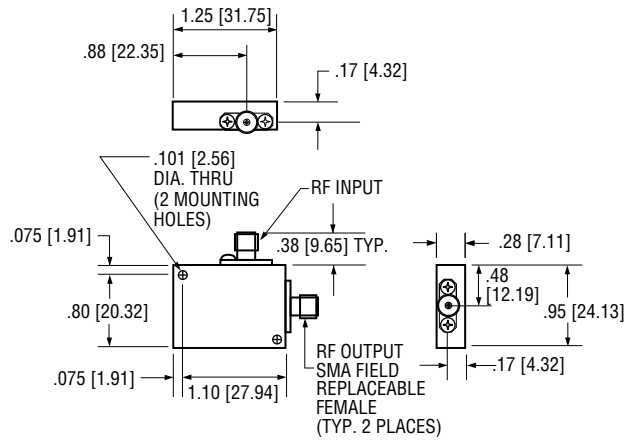

NOTE:

1. All dimensions shown in brackets [] are in millimeters.

PASSIVE FREQUENCY DOUBLERS (CONT.)

MODEL: SXS2M010060

ELECTRICAL SPECIFICATIONS

Input frequency range	0.5 – 3 GHz minimum
Output frequency range	1 – 6 GHz minimum
Input power range	8 – 12 dBm nominal
Conversion loss	13 dB typical 16 dB maximum
Optional input power	
SXS2J010060	3–8 dBm
SXS2H010060	12–16 dBm
Harmonic rejection	
Fundamental	-20 dB typical
Odd harmonic	-25 dB typical

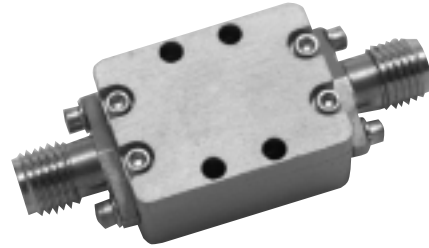

CONVERSION LOSS AND FUNDAMENTAL REJECTION VS. FREQUENCY

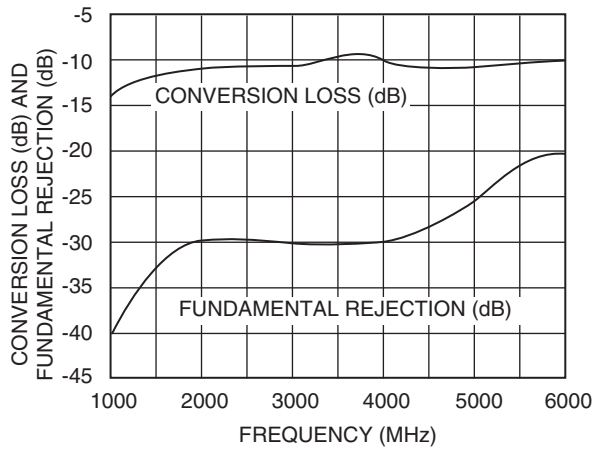

OUTLINE DRAWING

160057

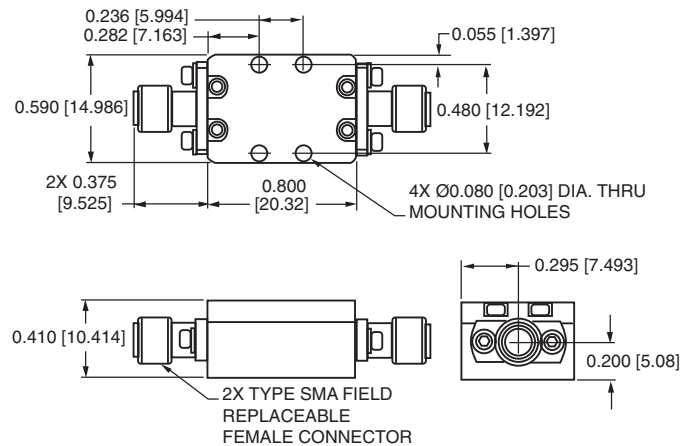

NOTE:

1. All dimensions shown in brackets [] are in millimeters.

PASSIVE FREQUENCY DOUBLER (CONT.)

MODEL: SXS01M

ELECTRICAL SPECIFICATIONS

Input frequency range	0.5 – 3 GHz minimum
Output frequency range	1 – 6 GHz minimum
Input power range	8 – 12 dBm nominal
Conversion loss	13 dB typical 16 dB maximum
Optional input power	
SXS02J	3–8 dBm
SXS03H	12–16 dBm
Harmonic rejection	
Fundamental	-20 dB typical
Odd harmonic	-25 dB typical

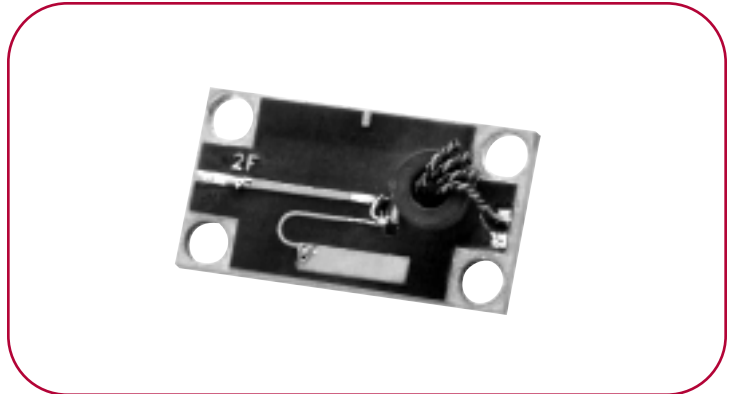

CONVERSION LOSS AND FUNDAMENTAL REJECTION VS. FREQUENCY

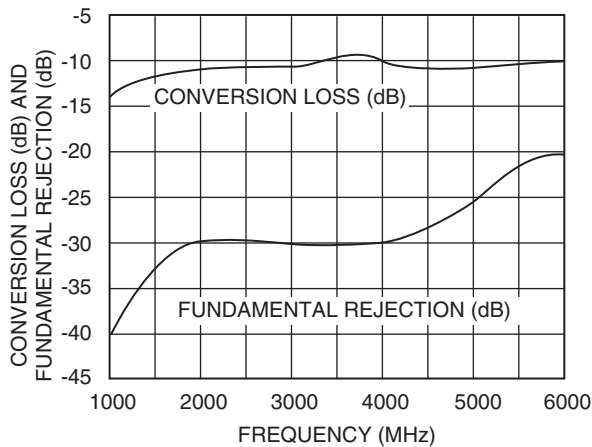

OUTLINE DRAWING

161565

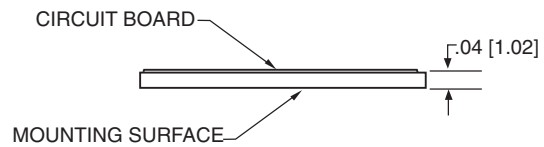
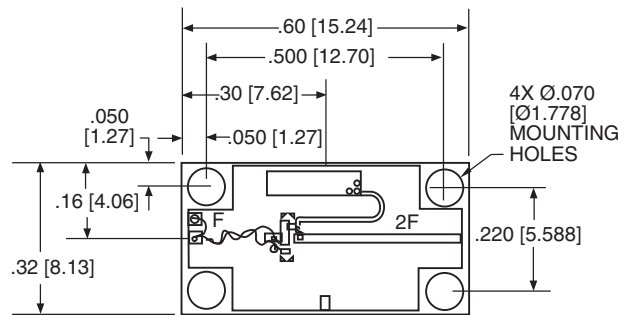

NOTE:

1. All dimensions shown in brackets [] are in millimeters.

PASSIVE FREQUENCY DOUBLERS (CONT.)

MODEL: MX2M030180-2C

ELECTRICAL SPECIFICATIONS

Input frequency range	1.5 – 9 GHz minimum
Output frequency range	3 – 18 GHz minimum
Input power range	8 – 12 dBm nominal (performance guaranteed at +10 dBm)
Conversion loss 15 dB maximum	12 dB typical
Optional input power	
M/N MX2J030180-2C	3–8 dBm (performance guaranteed at 5.5 dBm)
M/N MX2H030180-2C	12–16 dBm (performance guaranteed at 14 dBm)
M/N MX2V030180-2C	16–20 dBm (performance guaranteed at 18 dBm)
Harmonic rejection	
Fundamental	15 dB typical
Odd harmonic	20 dB typical



CONVERSION LOSS VS. FREQUENCY

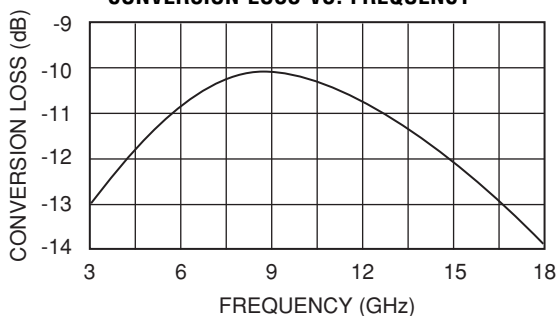

FUNDAMENTAL REJECTION VS. FREQUENCY

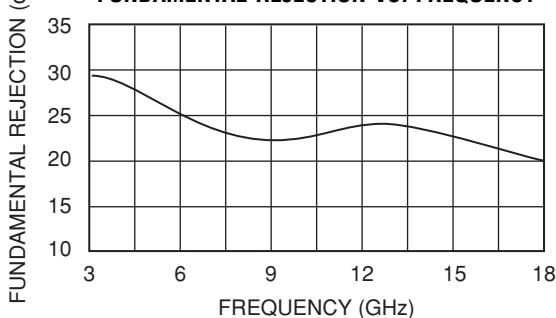

OUTPUT POWER VS. INPUT POWER
($P_{IN} = +10$ dBm)

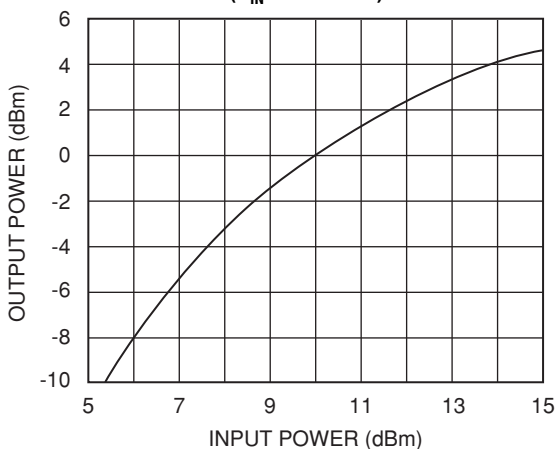

OUTLINE DRAWING

MX2C

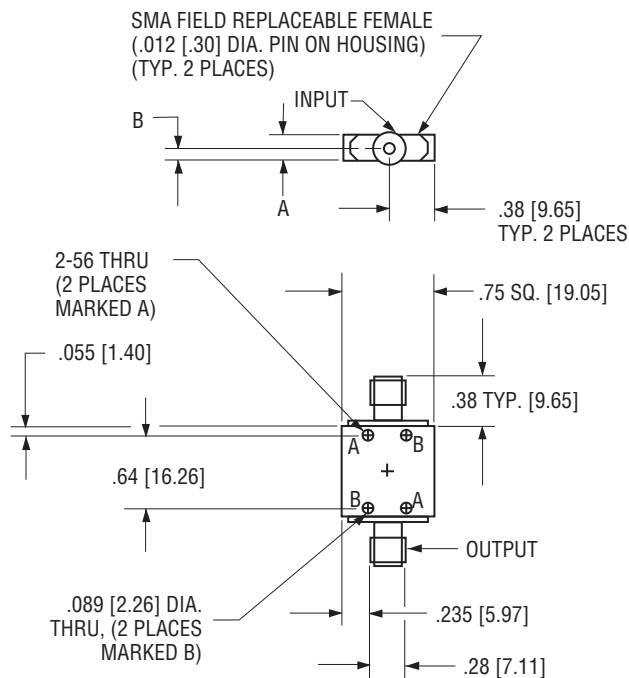

OUTLINE DASH NO.

DIM A

DIM B

-1

.226 [5.74]

.121 [3.07]

Notes:

- Dimensions are in inches [millimeters]
Tolerance as follows:
.xx = ± 0.01 [.xx = ± 0.25]
.xxx = ± 0.005 [.xxx = ± 0.13]

PASSIVE FREQUENCY DOUBLER (CONT.)

MODEL: SXS2M040180

ELECTRICAL SPECIFICATIONS

Input frequency range	2 – 9 GHz minimum
Output frequency range	4 – 18 GHz minimum
Input power range	8 – 12 dBm nominal
Conversion loss	13 dB typical 15 dB maximum
Optional input power	
SXS2J040180	3–8 dBm
SXS2H040180	12–16 dBm
Harmonic rejection	
Fundamental	-20 dB typical
Odd harmonic	-25 dB typical

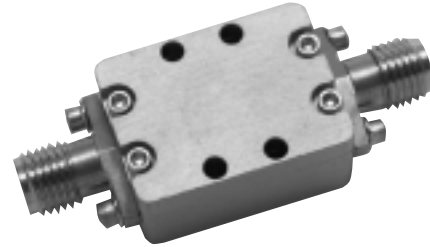

CONVERSION LOSS AND FUNDAMENTAL REJECTION VS. FREQUENCY

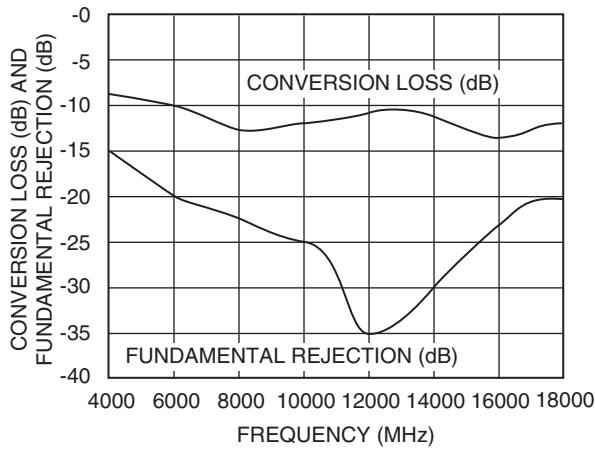

OUTLINE DRAWING

160057

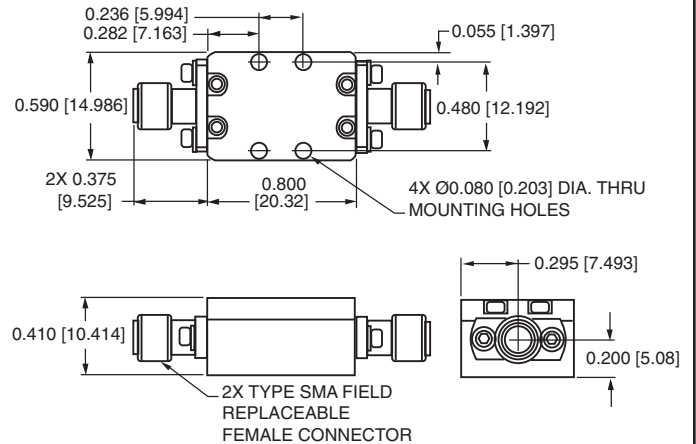

NOTE:

1. All dimensions shown in brackets [] are in millimeters.

PASSIVE FREQUENCY DOUBLERS (CONT.)

MODEL: SXS04M

ELECTRICAL SPECIFICATIONS

Frequency (MHz)	Conversion Loss (dB)	Fundamental Rejection (dB)
4000	-10	-15
6000	-11	-20
8000	-12	-24
10000	-12	-26
12000	-11	-35
14000	-11	-30
16000	-12	-24
18000	-11	-20



CONVERSION LOSS AND FUNDAMENTAL REJECTION VS. FREQUENCY

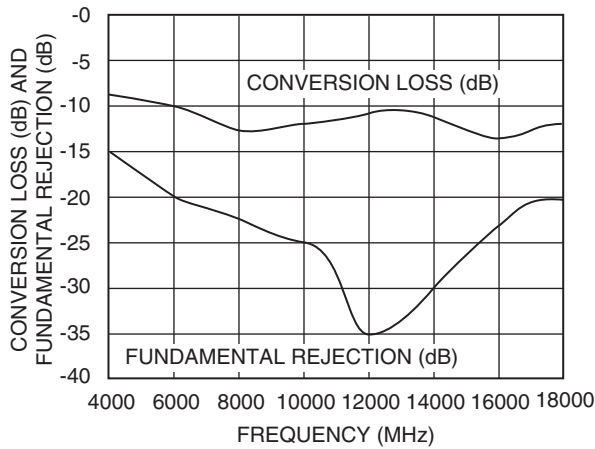

OUTLINE DRAWING

161566

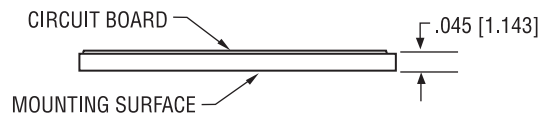
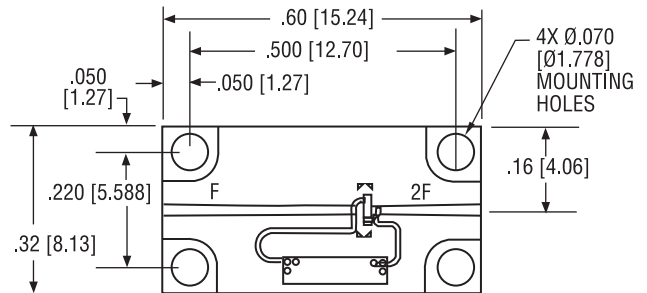

NOTE:

1. All dimensions shown in brackets [] are in millimeters.

PASSIVE FREQUENCY DOUBLERS (CONT.)

MODEL: MX2M060260

ELECTRICAL SPECIFICATIONS

Input frequency range	3 – 13 GHz minimum
Output frequency range	6 – 26 GHz minimum
Input power range	8 – 12 dBm nominal
Conversion loss	12 dB typical 18 dB maximum
Optional input power	
MX2J060260	3–8 dBm
MX2H060260	12–16 dBm
MX2V060260	16–20 dBm
Harmonic rejection	
Fundamental	15 dB typical
Odd harmonic	20 dB typical

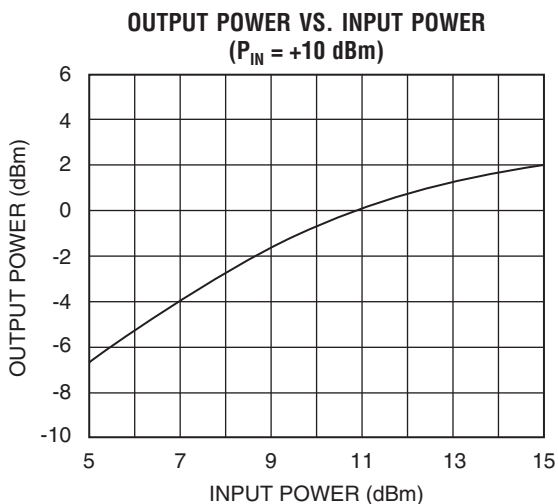
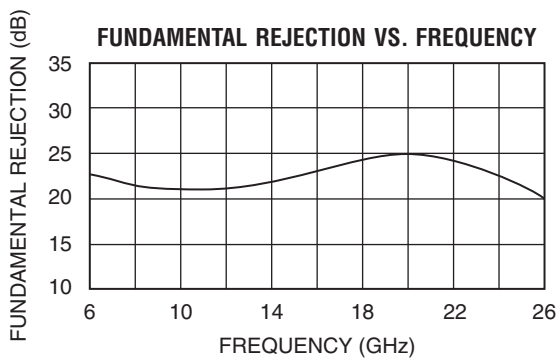
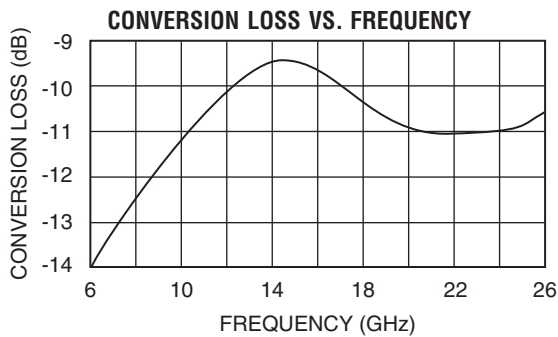
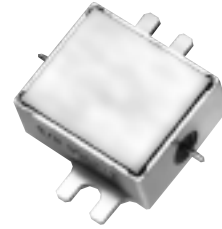

OUTLINE DRAWING

MX2D

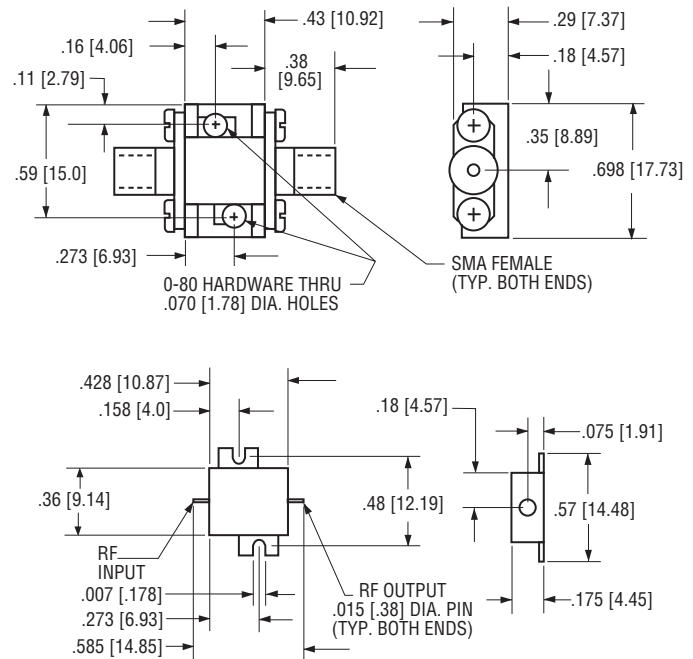

NOTES:

- Doubler may be readily used as is, or as a drop-in by removing the SMA connectors and mounting hardware as shown.
- All dimensions shown in brackets [] are in millimeters.

PASSIVE FREQUENCY DOUBLERS (CONT.)

MODEL: SXS2M060260

ELECTRICAL SPECIFICATIONS

Input frequency range	3 – 13 GHz minimum
Output frequency range	6 – 26 GHz minimum
Input power range	8 – 12 dBm nominal
Conversion loss	13 dB typical 17 dB maximum
Optional input power	
SXS2J060260	3–8 dBm
SXS2H060260	12–16 dBm
Harmonic rejection	
Fundamental	-18 dB typical
Odd harmonic	-25 dB typical

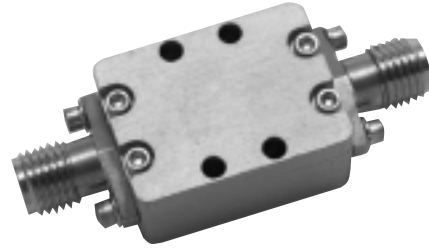

CONVERSION LOSS AND FUNDAMENTAL REJECTION VS. FREQUENCY

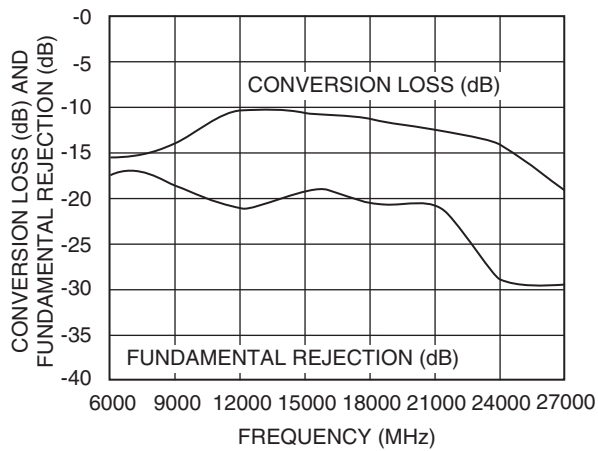

OUTLINE DRAWING

160057

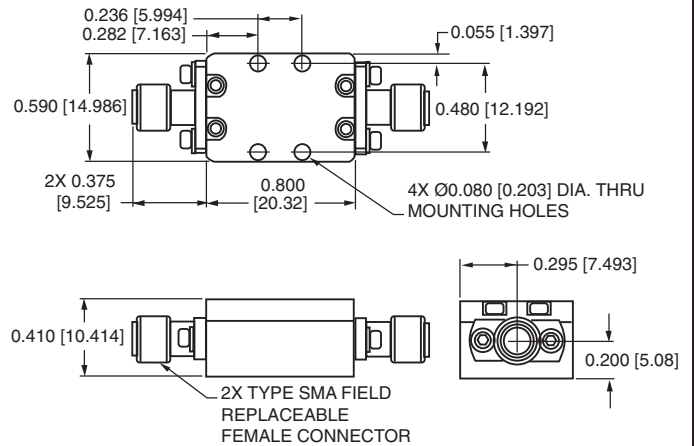

NOTE:

1. All dimensions shown in brackets [] are in millimeters.

PASSIVE FREQUENCY DOUBLERS (CONT.)

MODEL: SXS07M

ELECTRICAL SPECIFICATIONS

Input frequency range	3 – 13 GHz minimum
Output frequency range	6 – 26 GHz minimum
Input power range	8 – 12 dBm nominal
Conversion loss	13 dB typical 18 dB maximum
Optional input power	
SXS08J	3–8 dBm
SXS09H	12–16 dBm
Harmonic rejection	
Fundamental	-18 dB typical
Odd harmonic	-25 dB typical

FUNCTIONAL BLOCK DIAGRAM

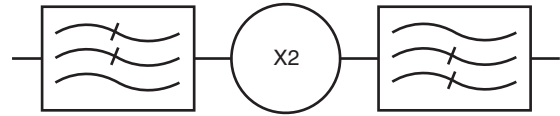

CONVERSION LOSS AND FUNDAMENTAL REJECTION VS. FREQUENCY

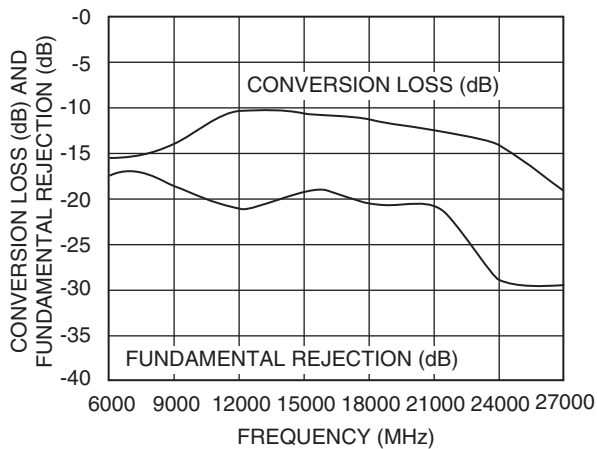

OUTLINE DRAWING

163124

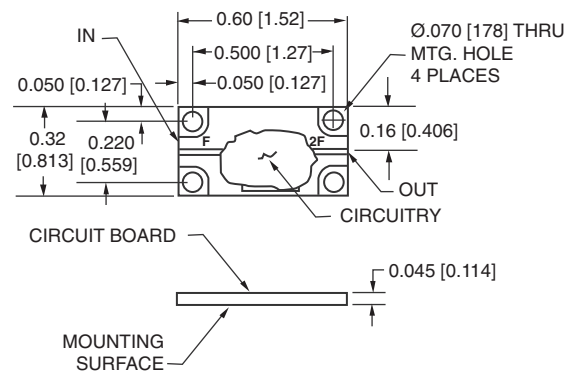

NOTE:

1. All dimensions shown in brackets [] are in millimeters.

4 TO 40 GHz OUTPUT LOW-NOISE FREQUENCY DOUBLER

MODEL: TD0040LA2

FEATURES

- RF input..... 2 to 20 GHz
- RF output 4 to 40 GHz
- Conversion loss 13 dB typical
- Isolation F_{in}/F_{out} 30 dB typical
- Output phase noise equivalent to passive Schottky diode mixer



This triple-balanced passive frequency multiplier is useful as a signal source in millimeter receivers or transmitters. A minimum input power of +10 dBm is required to achieve -3 dBm output using low-level diodes. Higher level diodes will yield +5 dBm output with +20 dBm input. An active version is also available with a +10 dBm output utilizing MITEQ's low-noise amplifiers.

ELECTRICAL SPECIFICATIONS

INPUT PARAMETERS	CONDITION	UNITS	MIN.	TYP.	MAX.
RF frequency range		GHz	2		20
RF VSWR		Ratio		3:1	
RF power range		dBm	+7	+10	+13
TRANSFER CHARACTERISTICS	CONDITION	UNITS	MIN.	TYP.	MAX.
Conversion loss (RF = +10 dBm)	4 to 40 GHz	dB		15	18
	12 to 32 GHz	dB		13	15
	18 to 26 GHz	dB		11	13
Isolation RF in to RF out	4 to 40 GHz	dB	20	25	
	12 to 32 GHz	dB	25	30	
	18 to 26 GHz	dB	27	33	
OUTPUT PARAMETERS	CONDITION	UNITS	MIN.	TYP.	MAX.
IF frequency range		GHz	4		40
Power diode	L	dBm		-3	
	H	dBm		5	
Active option	Input = +10	dBm		12	

TD0040LA2 TYPICAL TEST DATA

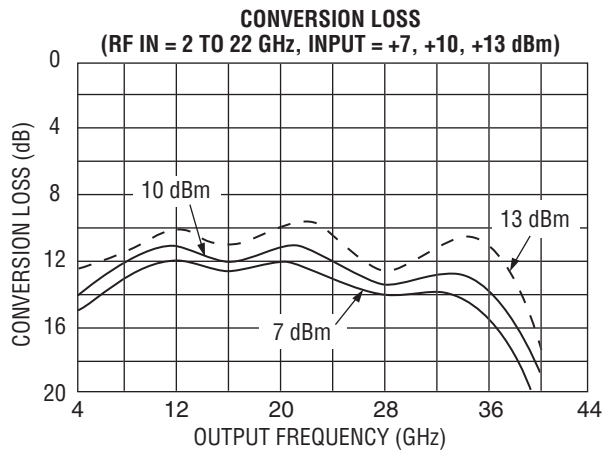
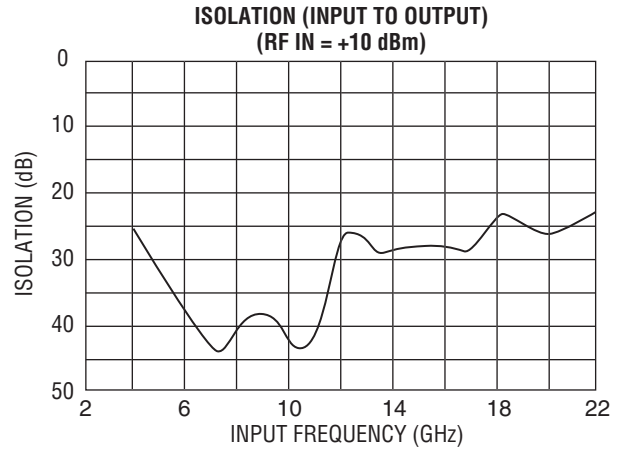
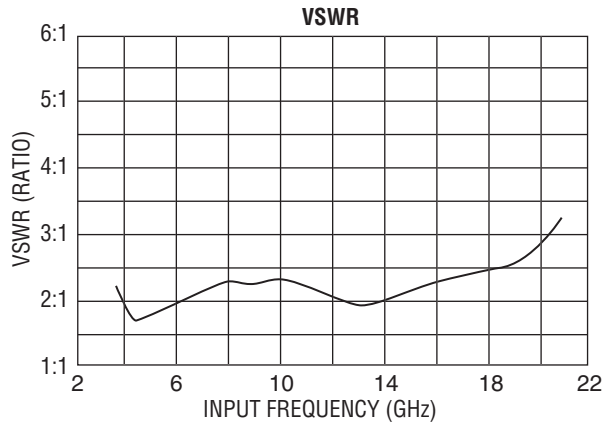

MAXIMUM RATINGS

Specification temperature..... +25°C
 Operating temperature -54 to +85°C
 Storage temperature -65 to +125°C

GENERAL NOTES

1. Input or output LNAs available.
2. Existing package is hermetically sealed.
3. Burn out = +23 dBm input.

OUTLINE DRAWING

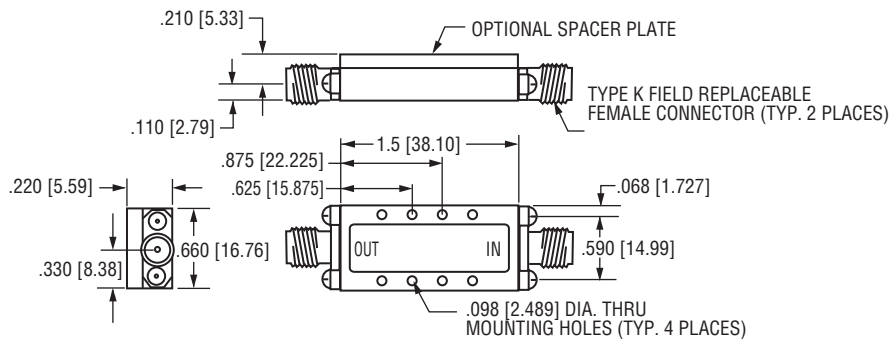

NOTE: All dimensions shown in brackets [] are in millimeters.

ACTIVE FREQUENCY DOUBLERS

MODEL: MAX2M260400

ELECTRICAL SPECIFICATIONS

Input frequency range	13 – 20 GHz
Output frequency range	26 – 40 GHz
Input power range	10 – 15 dBm nominal
Harmonic rejection	
Fundamental	18 dB typical
Odd harmonic	18 dB typical

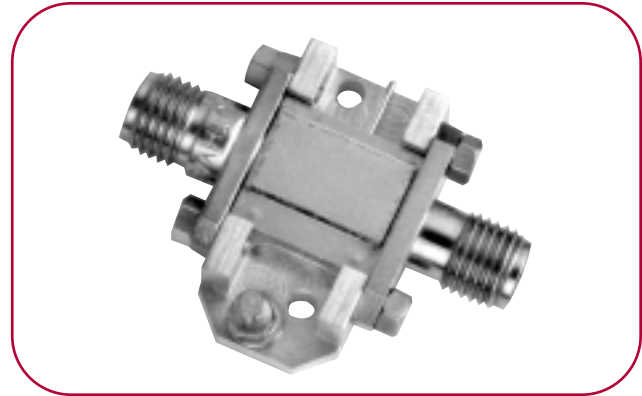

OUTPUT POWER VS. FREQUENCY

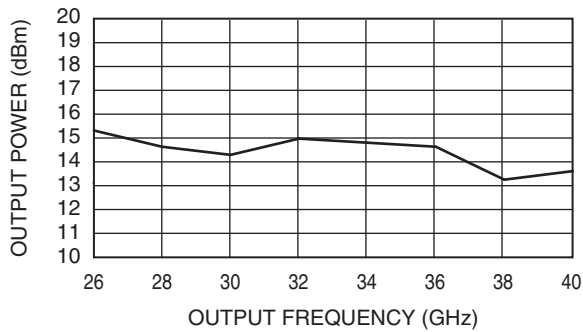

FUNDAMENTAL REJECTION VS. FREQUENCY ($P_{IN} = +10$ dBm)

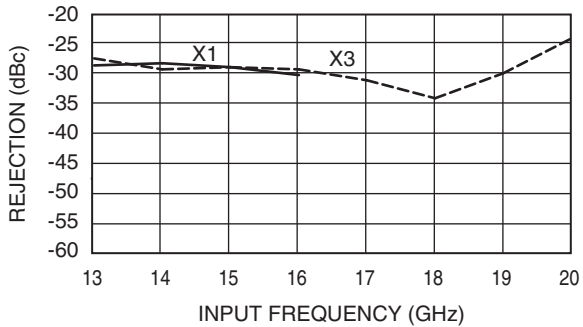

OUTLINE DRAWING

MAX2K

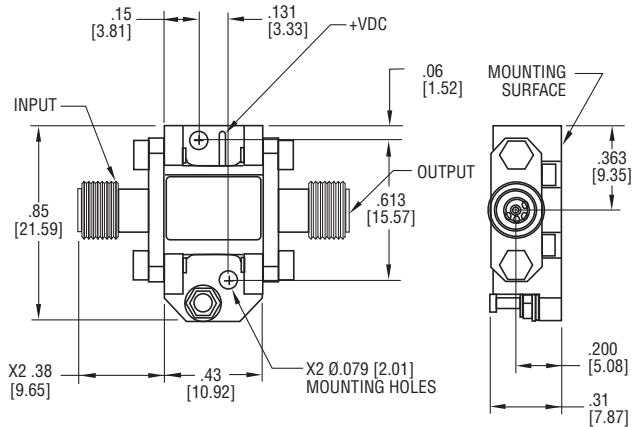

NOTES:

1. Optional input connectors SMA, K or output connectors K or V type male.
2. Optional waveguide output available, please contact MITEQ.
3. All dimensions shown in brackets [] are in millimeters.

ACTIVE FREQUENCY DOUBLERS (CONT.)

MODEL: MAX2M260400W (WAVEGUIDE WR28 OUTPUT)

ELECTRICAL SPECIFICATIONS

Input frequency range	13 – 20 GHz
Output frequency range	26 – 40 GHz
Input power range	8 – 12 dBm
Harmonic rejection	
Fundamental	> 20 dBc typical
Odd harmonic	> 20 dBc typical

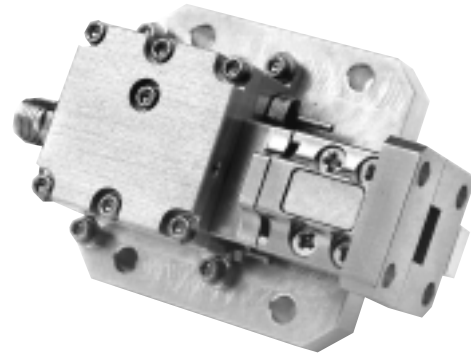

OUTPUT POWER VS. FREQUENCY

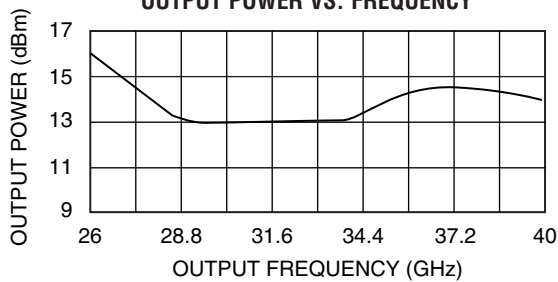

FUNDAMENTAL REJECTION VS. FREQUENCY
($P_{IN} = +10$ dBm)

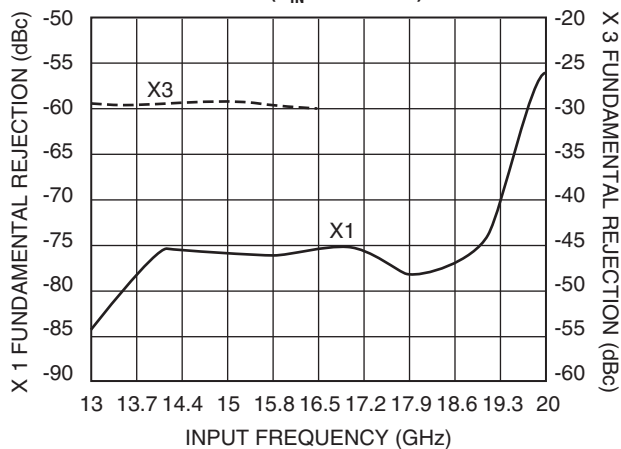

OUTLINE DRAWING

MAX2G

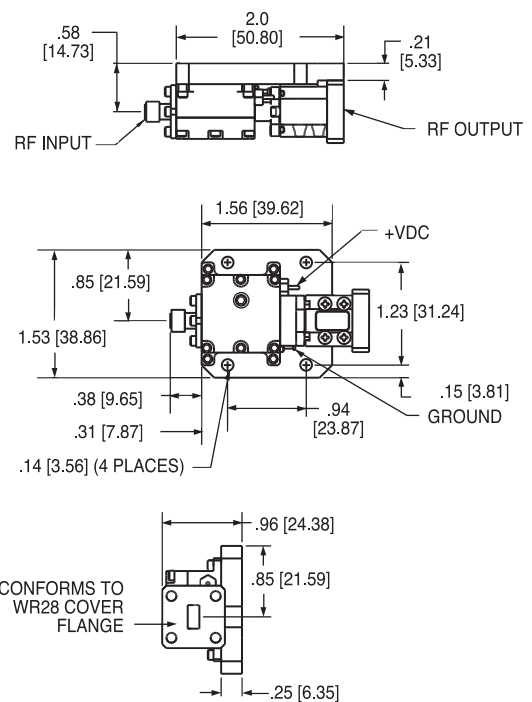

NOTES:

- Optional SMA or K type male/female connectors in input.
- All dimensions shown in brackets [] are in millimeters.

ACTIVE FREQUENCY DOUBLERS (CONT.)

MODEL: MAX2M300500

ELECTRICAL SPECIFICATIONS

Input frequency range	15 – 25 GHz
Output frequency range	30 – 50 GHz
Input power range	8 – 12 dBm
Harmonic rejection	
Fundamental	20 dBc typical
Odd harmonic	20 dBc typical

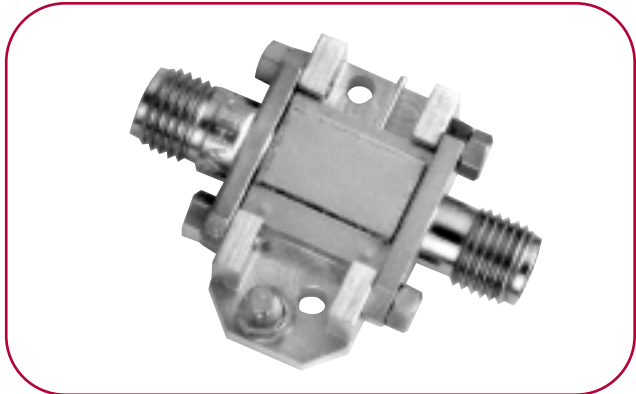

OUTPUT POWER VS. FREQUENCY

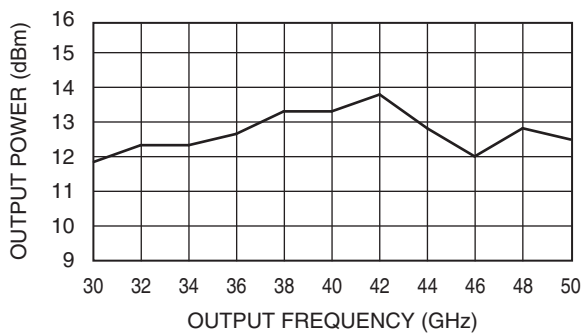

FUNDAMENTAL REJECTION VS. FREQUENCY ($P_{IN} = +10$ dBm)

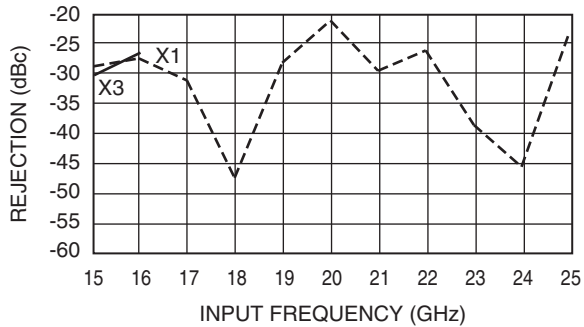

OUTLINE DRAWING

MAX2K

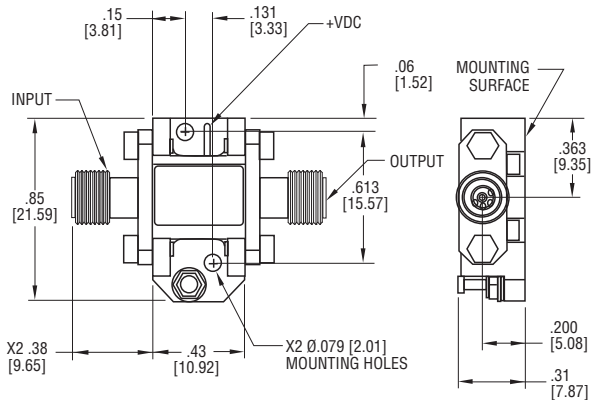

NOTES:

1. Optional input connectors SMA, K or output connectors V type male/female.
2. Optional waveguide output available, please contact MITEQ.
3. All dimensions shown in brackets [] are in millimeters.

ACTIVE FREQUENCY DOUBLERS (CONT.)

MODEL: MAX2M360500

ELECTRICAL SPECIFICATIONS

Input frequency range	18 – 25 GHz
Output frequency range	36 – 50 GHz
Input power range	10 – 15 dBm nominal
Harmonic rejection	
Fundamental	20 dBc typical
Odd harmonic	20 dBc typical

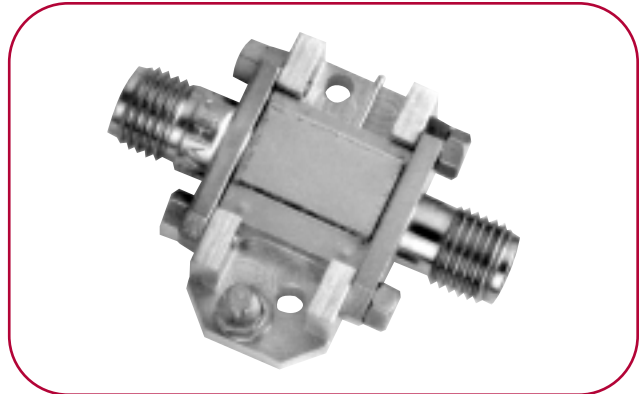

OUTPUT POWER VS. FREQUENCY

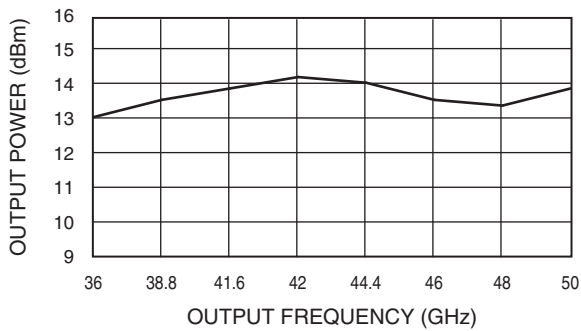

FUNDAMENTAL REJECTION VS. FREQUENCY ($P_{IN} = +10$ dBm)

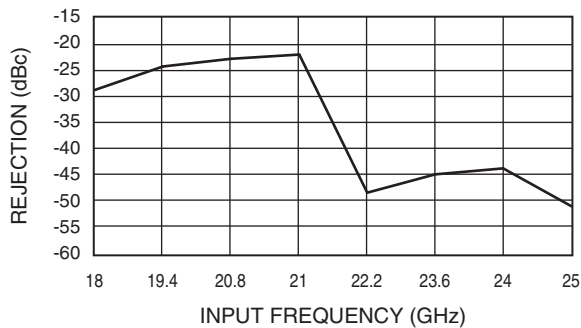

OUTLINE DRAWING

MAX2K

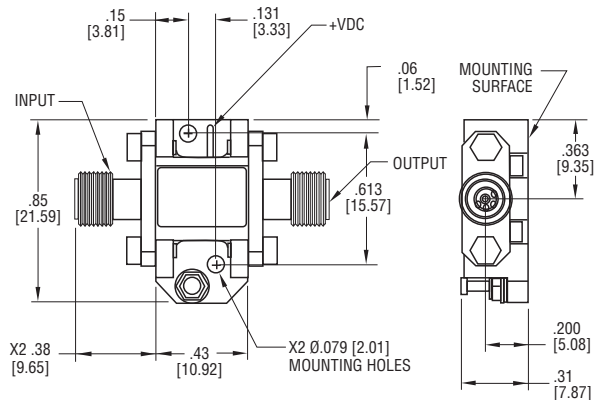

NOTES:

- Optional input connectors SMA, K or output connectors V type male/female.
- Optional waveguide output available, please contact MITEQ.
- All dimensions shown in brackets [] are in millimeters.

ACTIVE FREQUENCY DOUBLERS (CONT.)

MODEL: MAX2M390440-20P

ELECTRICAL SPECIFICATIONS

Input frequency range	19.5 – 22 GHz
Output frequency range	39 – 44 GHz minimum
Input power range	8 – 12 dBm nominal
Harmonic rejection	
Fundamental	20 dBc minimum
Odd harmonic	20 dBc minimum

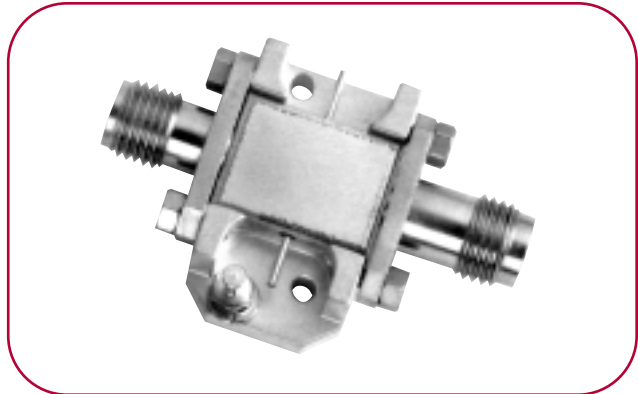

OUTPUT POWER VS. FREQUENCY

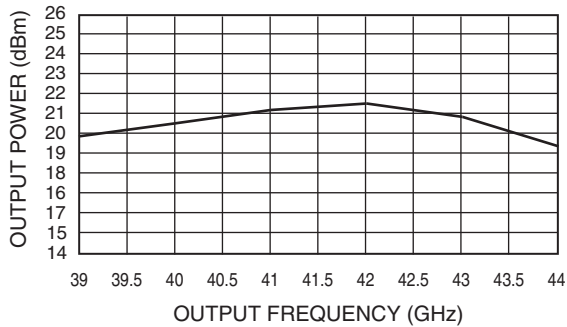

FUNDAMENTAL REJECTION VS. FREQUENCY
($P_{IN} = +10$ dBm)

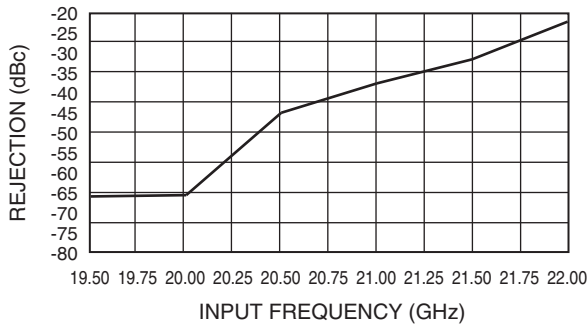

OUTLINE DRAWING

MAX2L

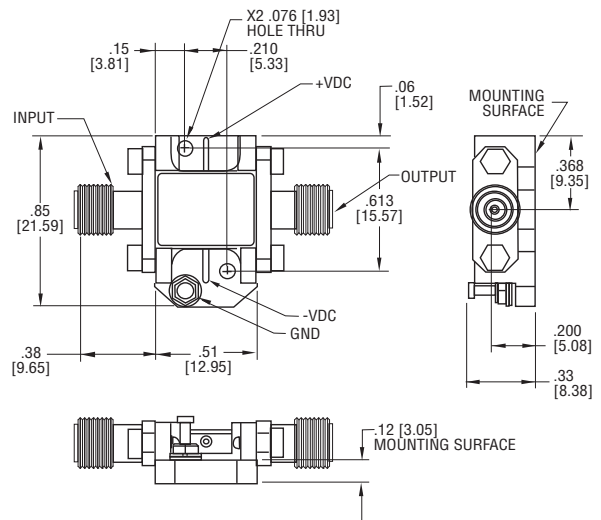

NOTES:

- Optional input connectors SMA, K or output connectors K or V type male.
- Optional waveguide output available, please contact MITEQ.
- All dimensions shown in brackets [] are in millimeters.

ACTIVE FREQUENCY DOUBLERS (CONT.)

MODEL: MAX2M020040

ELECTRICAL SPECIFICATIONS

Input frequency range	1 – 2 GHz minimum
Output frequency range	2 – 4 GHz minimum
Input power range	8 – 12 dBm nominal
Conversion loss	0 dB typical
Optional input/output power	
MAX2J020040	3–8 dBm
MAX2H020040	12–16 dBm
MAX2V020040	16–20 dBm
Harmonic rejection	
Fundamental	20 dB typical
Odd harmonic	20 dB typical
DC voltage/current	+5 volts @ 95 mA typical



OUTPUT POWER VS. FREQUENCY

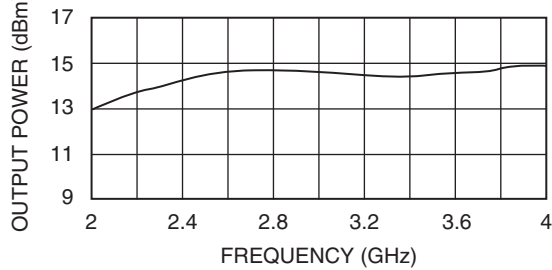

FUNDAMENTAL REJECTION VS. FREQUENCY ($P_{IN} = +10$ dBm)

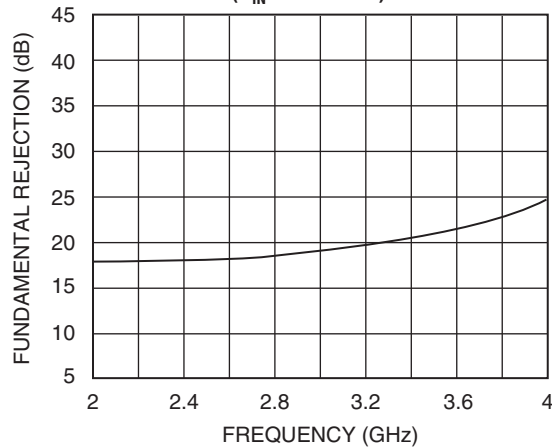

OUTLINE DRAWING

MAX2A2

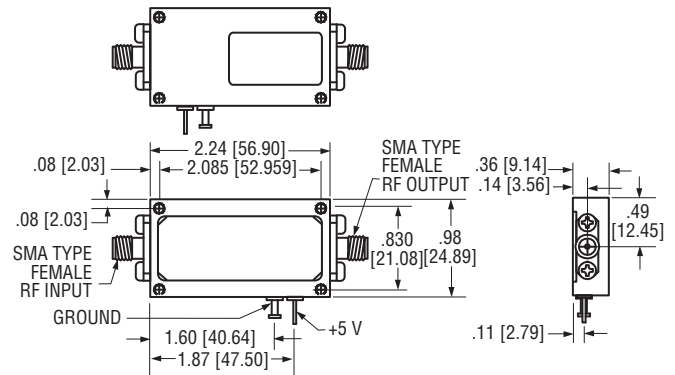

NOTE:

1. All dimensions shown in brackets [] are in millimeters.

ACTIVE FREQUENCY DOUBLERS (CONT.)

MODEL: MAX2M040080

ELECTRICAL SPECIFICATIONS

Parameter	Value

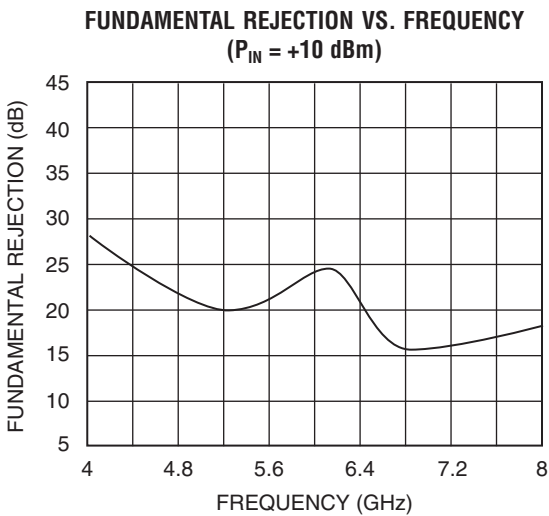
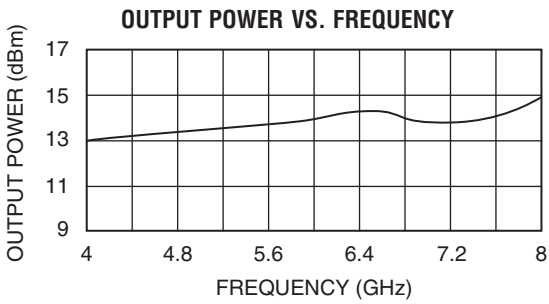

OUTLINE DRAWING

MAX2A2

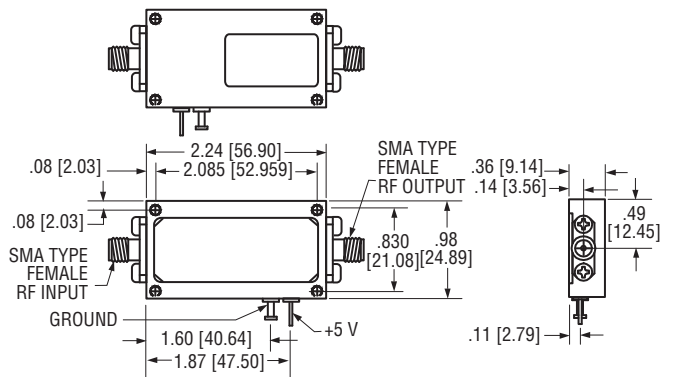

NOTE:

1. All dimensions shown in brackets [] are in millimeters.

ACTIVE FREQUENCY DOUBLERS (CONT.)

MODEL: SYS2J060120

ELECTRICAL SPECIFICATIONS

Input frequency range	3 – 6 GHz minimum
Output frequency range	6 – 12 GHz minimum
Input power range	5 dBm
Output level	+12 dB minimum
Input harmonic rejection	
Fundamental	-20 dB typical
Odd harmonic	-20 dB typical
DC voltage/current	+5/120

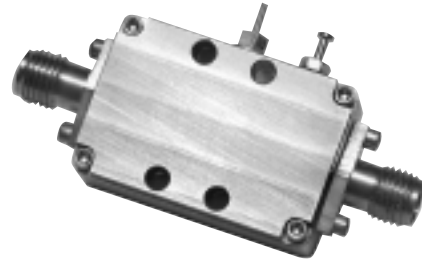

OUTPUT POWER VS. FREQUENCY

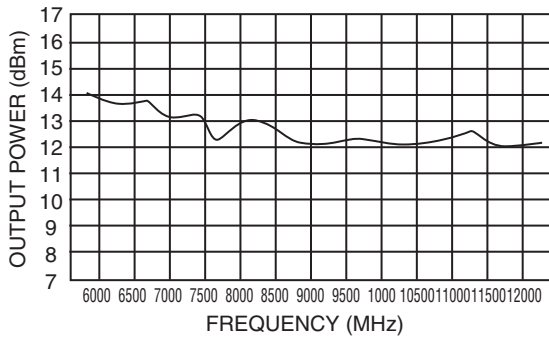

HARMONIC REJECTION

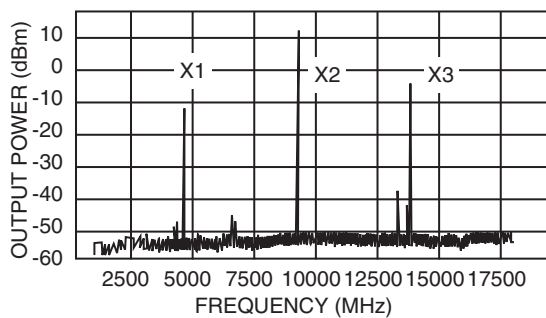

OUTLINE DRAWING

157637

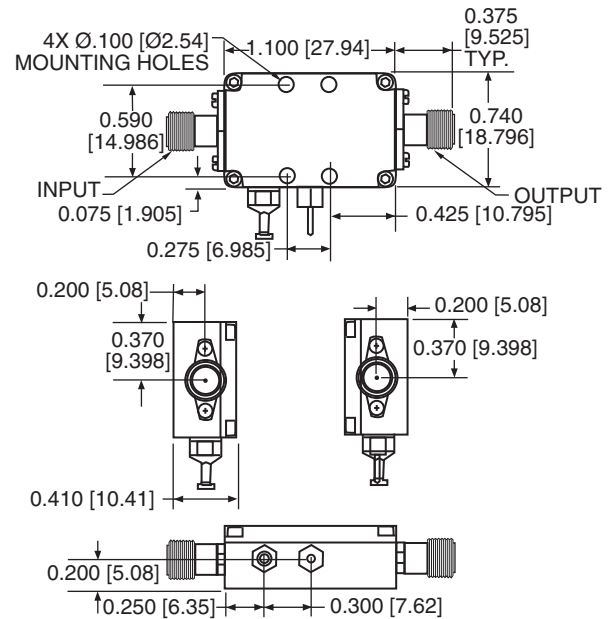

NOTE:

1. All dimensions shown in brackets [] are in millimeters.

ACTIVE FREQUENCY DOUBLERS (CONT.)

MODEL: SYS01J

ELECTRICAL SPECIFICATIONS

Input frequency range	3 – 6 GHz minimum
Output frequency range	6 – 12 GHz minimum
Input power range	5 dBm
Output level	+12 dB minimum
Input harmonic rejection	
Fundamental	-20 dB typical
Odd harmonic	-20 dB typical
DC voltage/current	+5/120

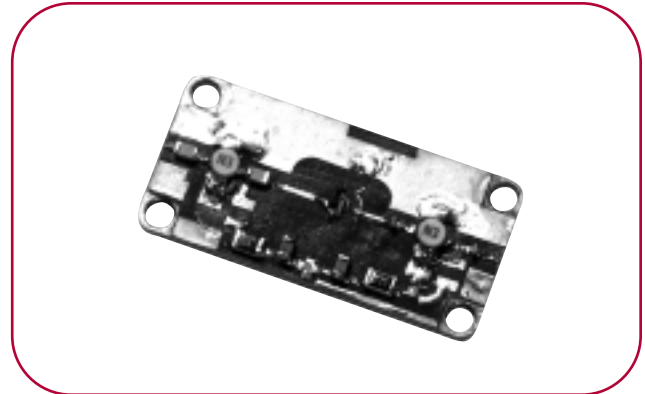

OUTPUT POWER VS. FREQUENCY

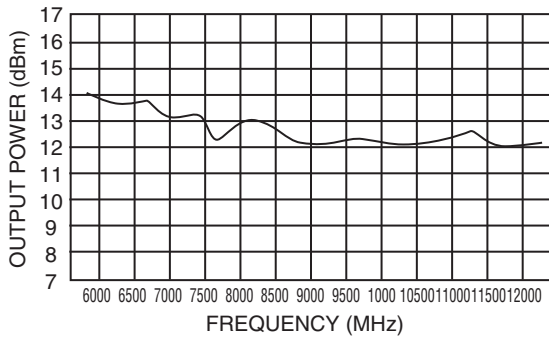

HARMONIC REJECTION

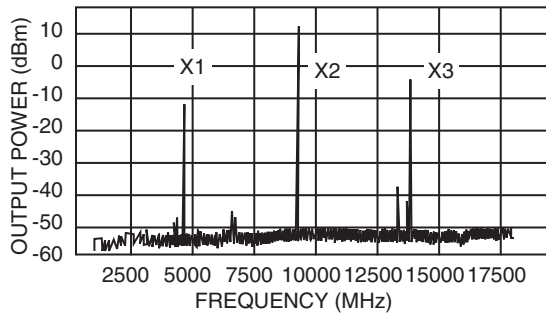

OUTLINE DRAWING

162011

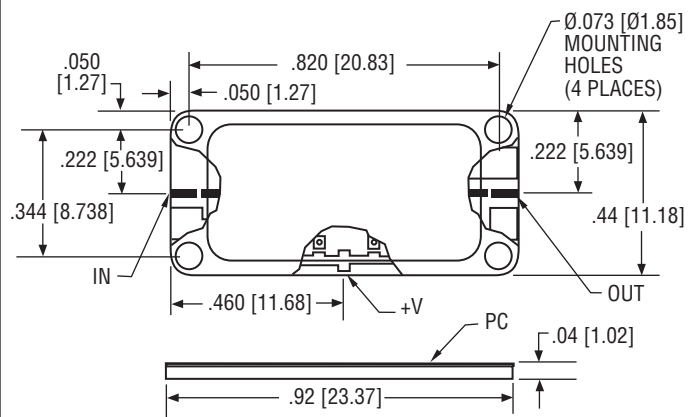

NOTE:

1. All dimensions shown in brackets [] are in millimeters.

ACTIVE FREQUENCY DOUBLERS (CONT.)

MODEL: MAX2M080160

ELECTRICAL SPECIFICATIONS

Input frequency range	4 – 8 GHz minimum
Output frequency range	8 – 16 GHz minimum
Input power range	8 – 12 dBm nominal
Conversion loss	0 dB typical
Optional input/output power	
MAX2J080160	3–8 dBm
MAX2H080160	12–16 dBm
MAX2V080160	16–20 dBm
Harmonic rejection	
Fundamental	20 dB typical
Odd harmonic	20 dB typical
DC voltage/current	+15 volts @ 160 mA typical

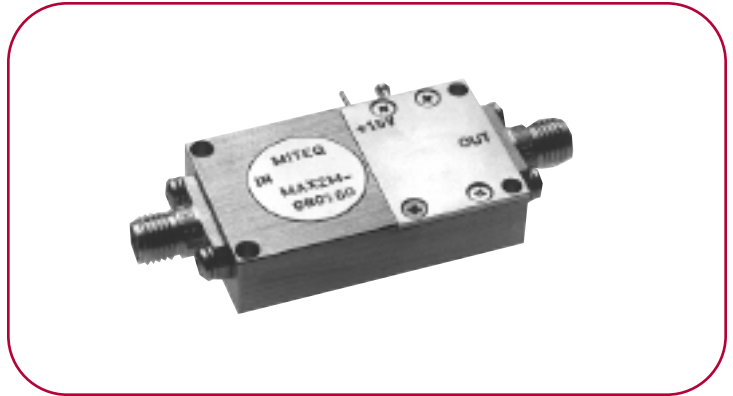

OUTPUT POWER VS. FREQUENCY

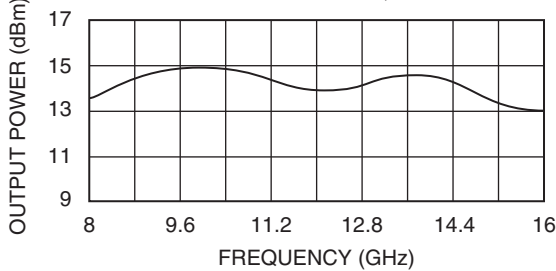

FUNDAMENTAL REJECTION VS. FREQUENCY
($P_{IN} = +10$ dBm)

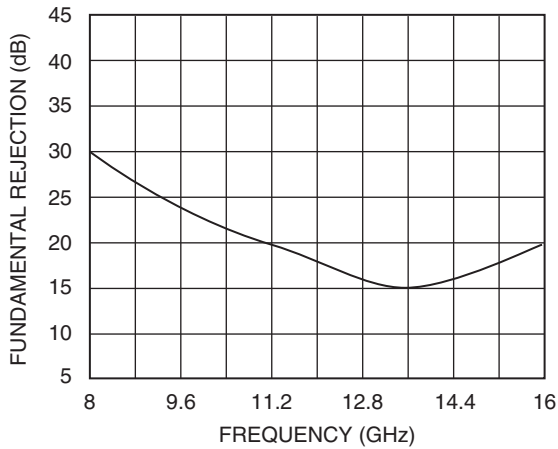

OUTLINE DRAWING

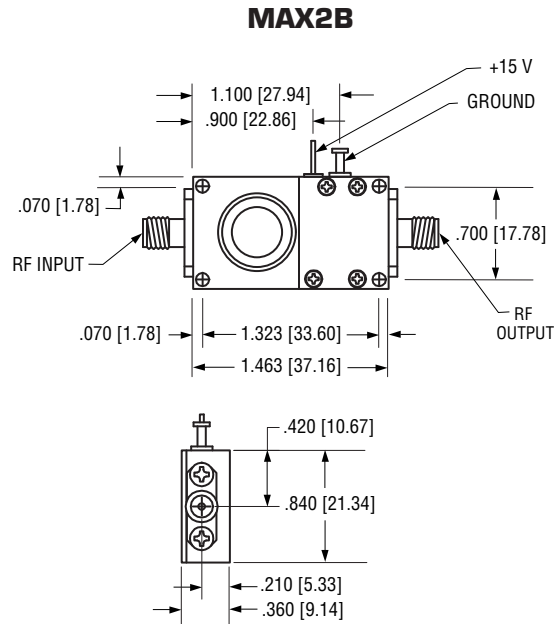

NOTE:

1. All dimensions shown in brackets [] are in millimeters.

ACTIVE FREQUENCY DOUBLERS (CONT.)

MODEL: SYS2M130260

ELECTRICAL SPECIFICATIONS

Input frequency range	6.5 – 13 GHz minimum
Output frequency range	13 – 26 GHz minimum
Input power range	8 – 12 dBm nominal
Conversion gain	0 dB typical
Optional input/output power	
SYS2J130260	3–8 dBm
SYS2H130260	12–16 dBm
SYS2V130260	16–20 dBm
Harmonic rejection	
Fundamental	-20 dB typical
Odd harmonic	-20 dB typical
DC voltage/current	+15/100
SYS2V130260	+15/350

FUNCTIONAL BLOCK DIAGRAM

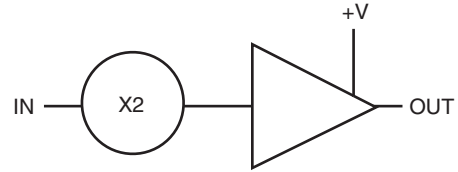

OUTPUT POWER VS. FREQUENCY

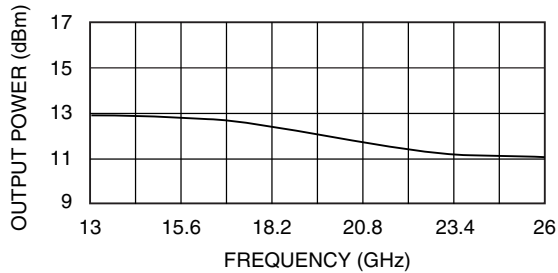

FUNDAMENTAL REJECTION VS. FREQUENCY ($P_{IN} = +10$ dBm)

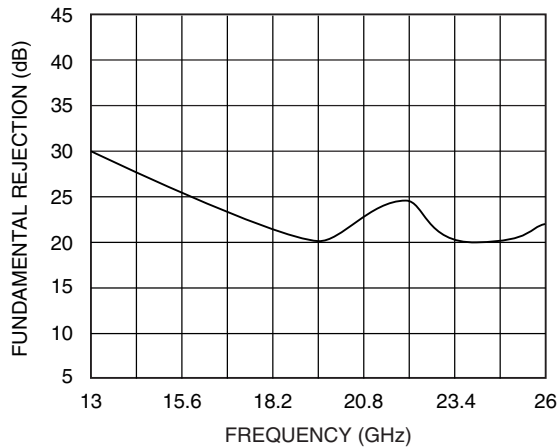

OUTLINE DRAWING

160833

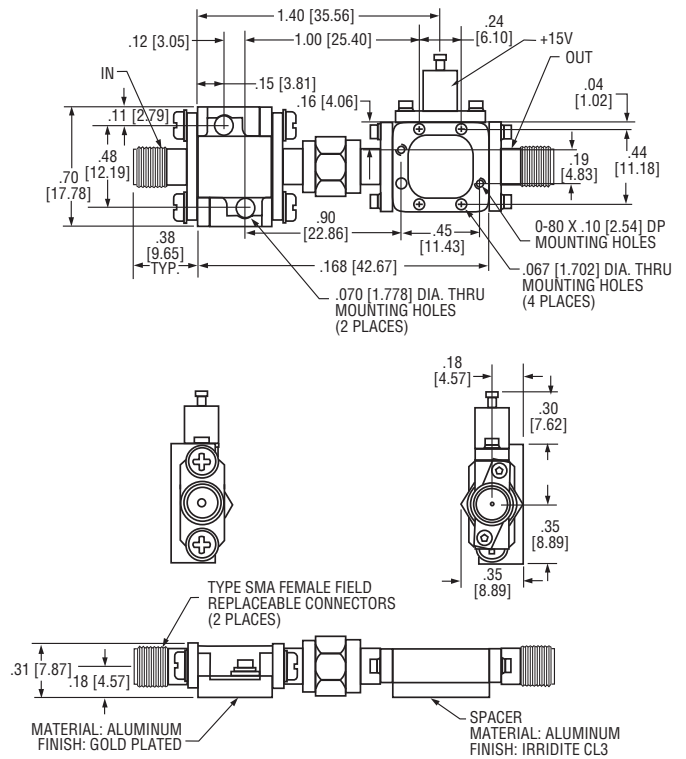

NOTE:

1. All dimensions shown in brackets [] are in millimeters.

ACTIVE FREQUENCY DOUBLERS (CONT.)

MODEL: MAX2M200400

ELECTRICAL SPECIFICATIONS

Input frequency range	10 – 20 GHz
Output frequency range	20 – 40 GHz
Input power range	8 – 12 dBm
Harmonic rejection	
Fundamental	20 dBc minimum
Odd harmonic	20 dBc minimum

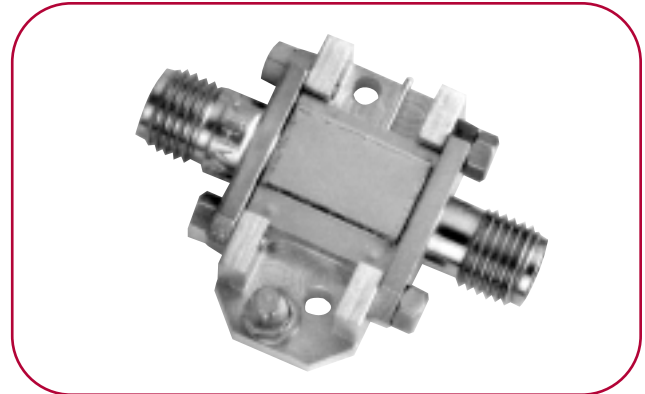

OUTPUT POWER VS. FREQUENCY

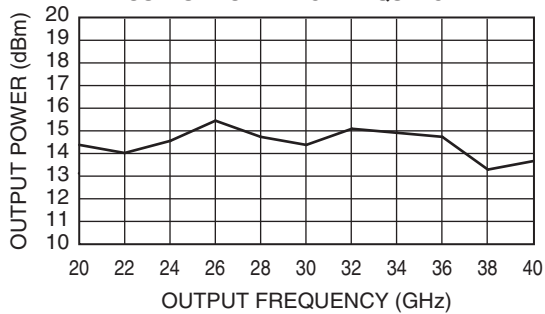

FUNDAMENTAL HARMONIC REJECTION VS. FREQUENCY ($P_{IN} = +10$ dBm)

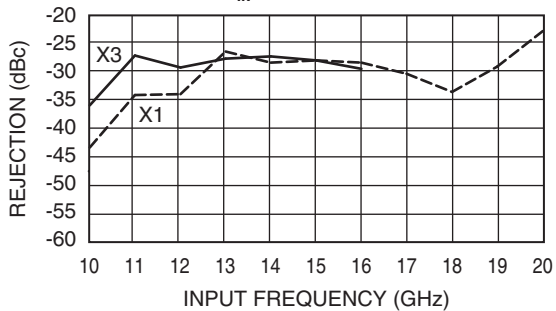

OUTLINE DRAWING

MAX2K

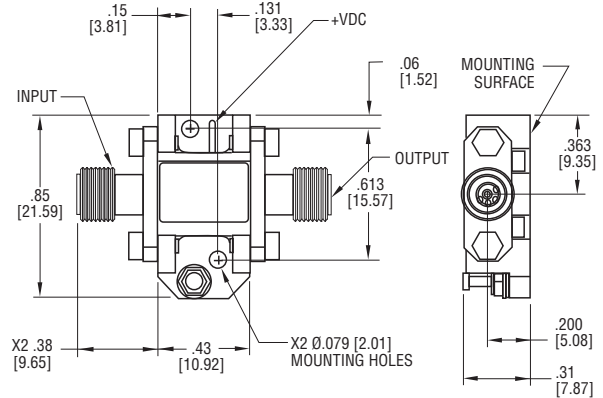

NOTES:

- Optional input connectors SMA, K or output connectors K or V type male.
- Optional waveguide output available, please contact MITEQ.
- All dimensions shown in brackets [] are in millimeters.

ACTIVE FREQUENCY DOUBLERS (CONT.)

MODEL: MAX2M200400-20P

ELECTRICAL SPECIFICATIONS

Input frequency range	10 – 20 GHz
Output frequency range	20 – 40 GHz
Input power range	8 – 12 dBm
Harmonic rejection	
Fundamental	20 dBc minimum
Odd harmonic	20 dBc minimum

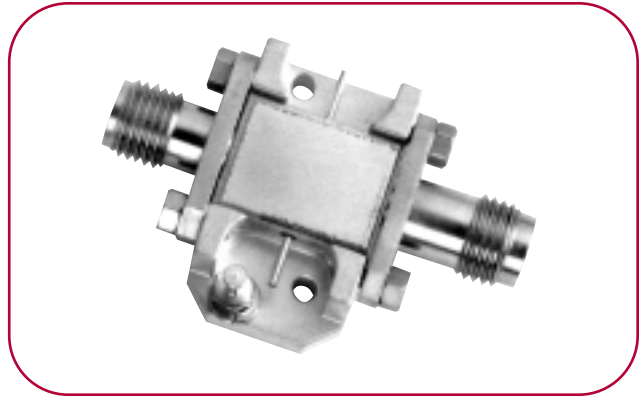

OUTPUT POWER VS. FREQUENCY

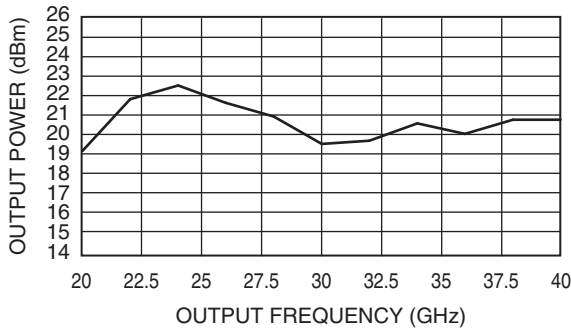

FUNDAMENTAL HARMONIC REJECTION VS. FREQUENCY
($P_{IN} = +10$ dBm)

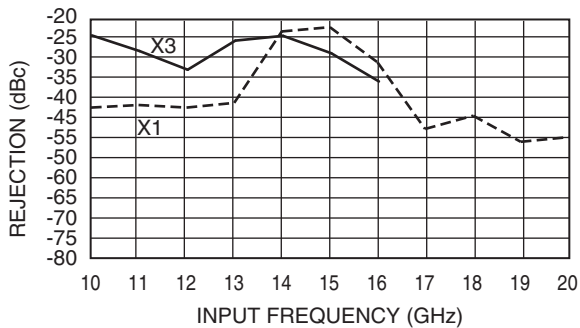

OUTLINE DRAWING

MAX2L

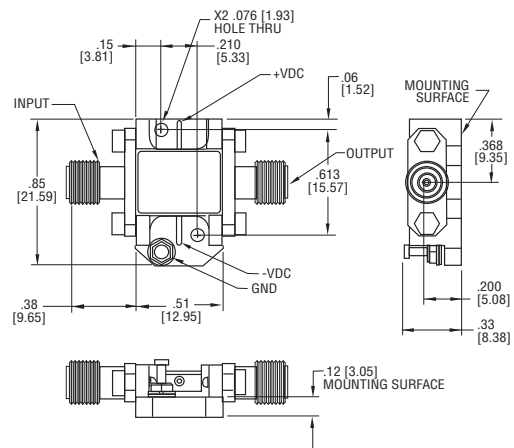

NOTES:

- Optional input connectors SMA, K or output connectors K or V type male.
- Optional waveguide output available, please contact MITEQ.
- All dimensions shown in brackets [] are in millimeters.

ACTIVE FREQUENCY DOUBLERS (CONT.)

MODEL: MAX2M010060

ELECTRICAL SPECIFICATIONS

Input frequency range	0.5 – 3 GHz minimum
Output frequency range	1 – 6 GHz minimum
Input power range	8 – 12 dBm nominal
Conversion loss	0 dB typical
Optional input/output power	
MAX2J010060	3–8 dBm
MAX2H010060	12–16 dBm
MAX2V010060	16–20 dBm
Harmonic rejection	
Fundamental	20 dB typical
Odd harmonic	20 dB typical
DC voltage/current	+5 volts @ 95 mA typical

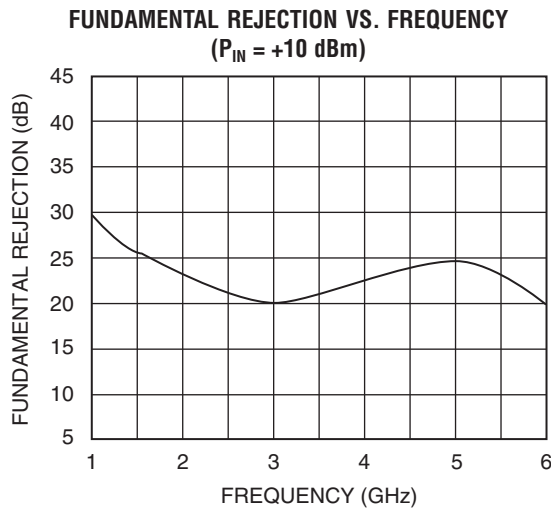
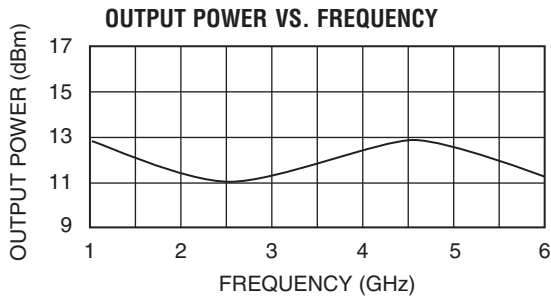

OUTLINE DRAWING

MAX2A2

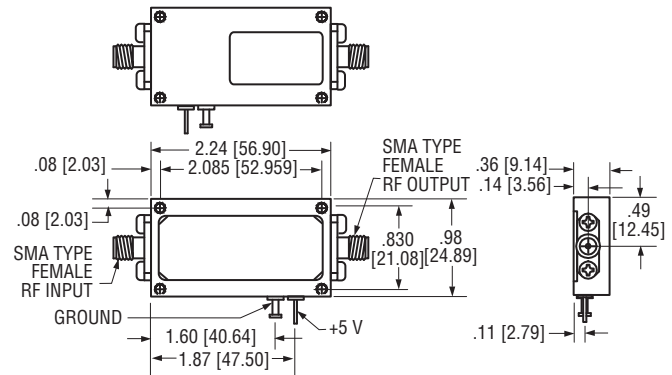

NOTE:

1. All dimensions shown in brackets [] are in millimeters.

ACTIVE FREQUENCY DOUBLERS (CONT.)

MODEL: MAX2M030180

ELECTRICAL SPECIFICATIONS

Input frequency range	1.5 – 9 GHz minimum
Output frequency range	3 – 18 GHz minimum
Input power range	8 – 12 dBm nominal
Conversion loss	0 dB typical
Optional input/output power	
MAX2J030180	3–8 dBm
MAX2H030180	12–16 dBm
MAX2V030180	16–20 dBm
Harmonic rejection	
Fundamental	15 dB typical
Odd harmonic	20 dB typical
DC voltage/current	+15 volts @ 160 mA typical

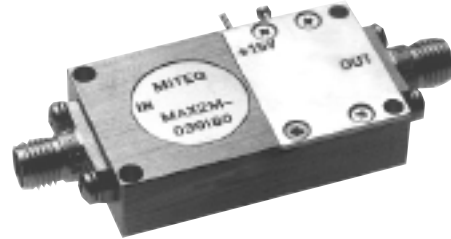

OUTPUT POWER VS. FREQUENCY

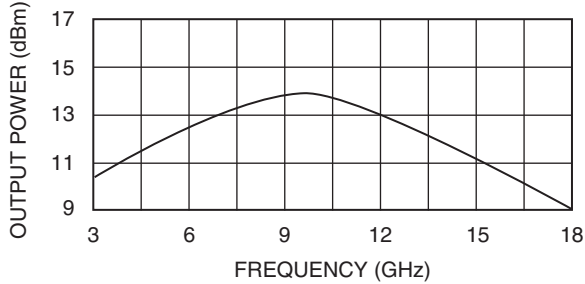

FUNDAMENTAL REJECTION VS. FREQUENCY
($P_{IN} = +10$ dBm)

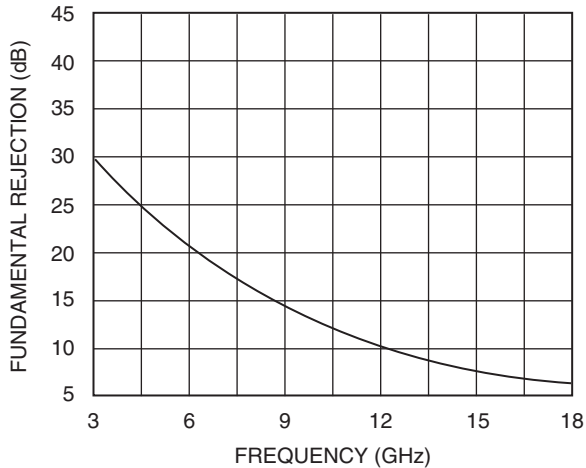

OUTLINE DRAWING

MAX2B

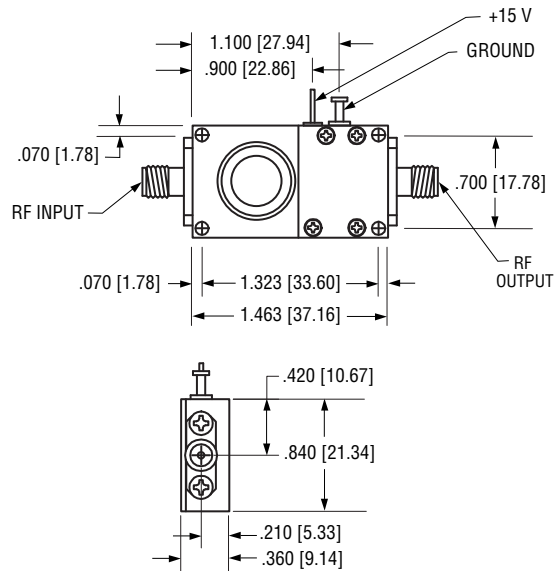

NOTE:

1. All dimensions shown in brackets [] are in millimeters.

ACTIVE FREQUENCY DOUBLERS (CONT.)

MODEL: MAX2M060260

ELECTRICAL SPECIFICATIONS

Input frequency range	3 – 13 GHz minimum
Output frequency range	6 – 26 GHz minimum
Input power range	8 – 12 dBm nominal
Conversion loss	0 dB typical
Harmonic rejection	
Fundamental	12 dB typical
Odd harmonic	15 dB typical

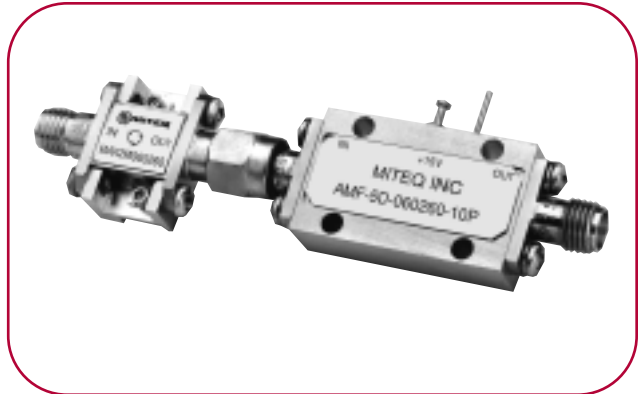

OUTPUT POWER VS. FREQUENCY

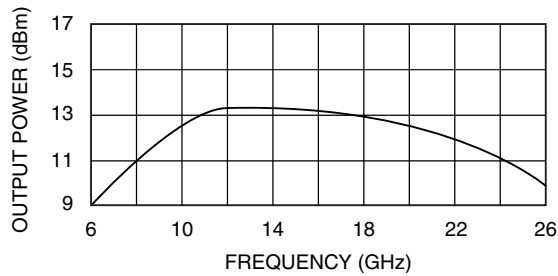

FUNDAMENTAL REJECTION VS. FREQUENCY
($P_{IN} = +10$ dBm)

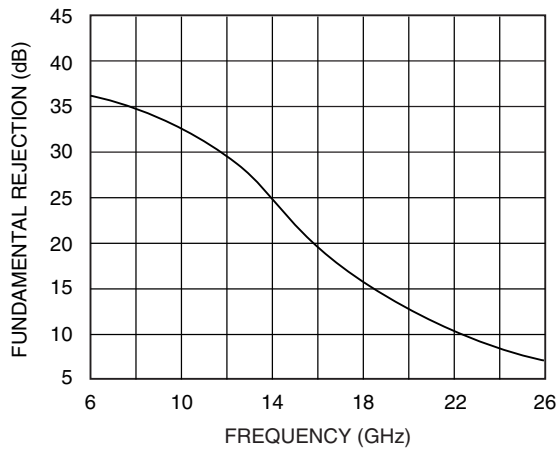

OUTLINE DRAWING

MAX2C

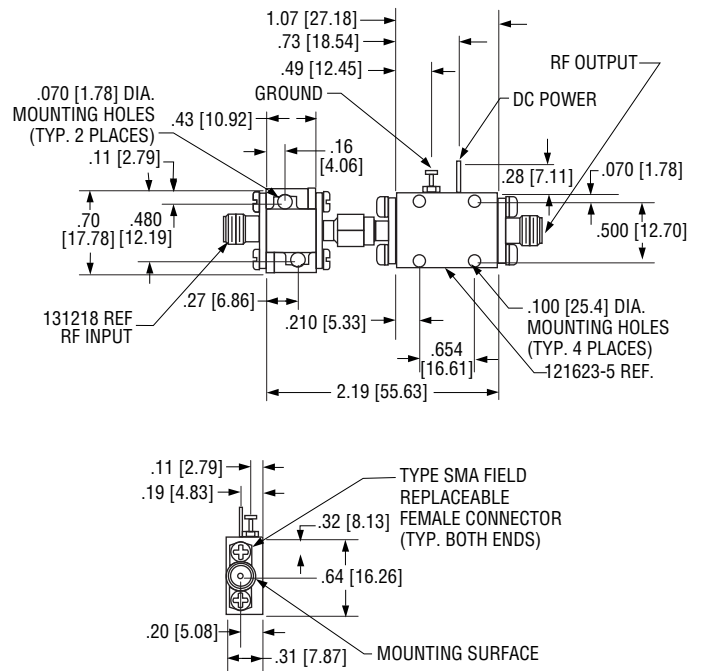

NOTE:

1. All dimensions shown in brackets [] are in millimeters.

ACTIVE FREQUENCY DOUBLERS (CONT.)

MODEL: SYS2J150450

ELECTRICAL SPECIFICATIONS

Input frequency range	7.5 – 22 GHz minimum
Output frequency range	15 – 45 GHz minimum
Requires regulated	-5 V, 50 mA +15 V, 220 mA
Input power range	3 dBm nominal
Conversion gain	10 dB typical
Harmonic rejection	
Fundamental	-20 dB typical
Odd harmonic	-20 dB typical

CONVERSION GAIN VS. FREQUENCY

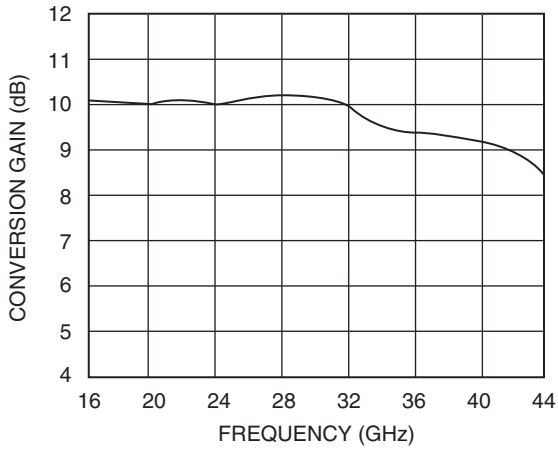

FUNDAMENTAL REJECTION VS. FREQUENCY

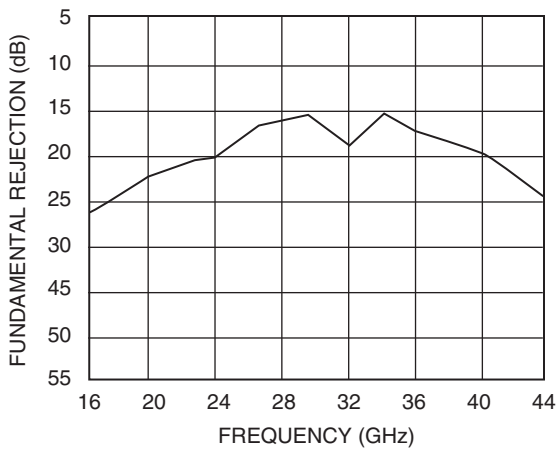

OUTLINE DRAWING

163640

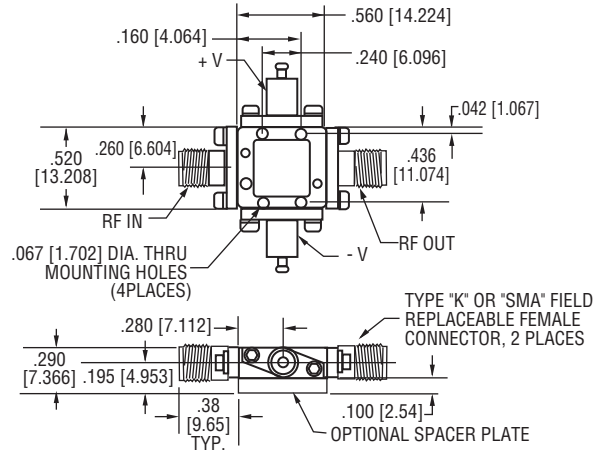

NOTES:

1. Unit's mounting surface shall be attached to a heatsink capable of dissipating the device's power consumption without exceeding the operating temperature limits.
2. Refer to the actual device specification sheet for bias requirements. Negative bias input voltage (v-) may not be included on certain models.
3. Unless noted on the specification sheet, when negative bias is required, do not power the unit with positive bias for more than one second without the negative bias being applied.
4. All dimensions shown in brackets [] are in millimeters.

ACTIVE 2X FREQUENCY MULTIPLIER

MODEL: SYS2X1122

FEATURES

- High fundamental rejection..... -50 dBc
- Output power..... 0 dBm
- RF output monitor
- Packaging Hermetically sealed

ELECTRICAL SPECIFICATIONS

INPUT PARAMETERS	CONDITION	UNITS	MIN.	TYP.	MAX.
RF frequency range		GHz	9.5		11.5
RF VSWR	50 ohm reference	Ratio		2.5:1	
RF power range		dBm	-5		
V+ bias voltage	@ 250 mA max.	VDC	9		16
V- bias voltage	@ 15 mA max.	VDC	-9		-16
TRANSFER CHARACTERISTICS	CONDITION	UNITS	MIN.	TYP.	MAX.
Output power		dBm	0		
Fundamental leakage	Input	dBc			-50
OUTPUT PARAMETERS	CONDITION	UNITS	MIN.	TYP.	MAX.
RF frequency range		GHz	19		23
RF VSWR	50 ohm reference	Ratio		2.5:1	
RF power		dBm	0		
RF monitor		dBm		-20	

NOTE: Test data supplied at 25°C;
fundamental rejection, output power and RF monitor.

MAXIMUM RATINGS

Specification temperature..... +25°C
Operating temperature -40 to +65°C
Storage temperature..... -65 to +95°C

OUTLINE DRAWING

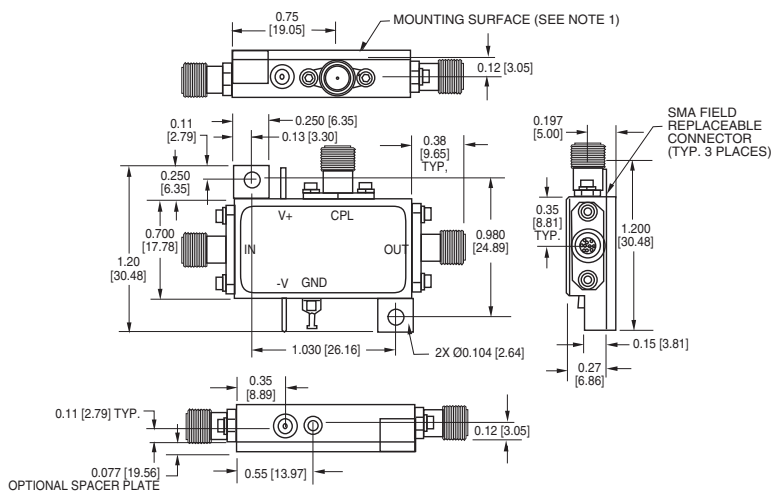

- NOTES: 1. Unit's mounting surface shall be attached to a heatsink capable of dissipating the devices power consumption without exceeding the operating temperature limits.
2. All dimensions shown in brackets [] are in millimeters.

ADD SUFFIX TO MODEL NO.

WG (WR42)
S

OPTIONS

WR42 output waveguide
Single positive supply

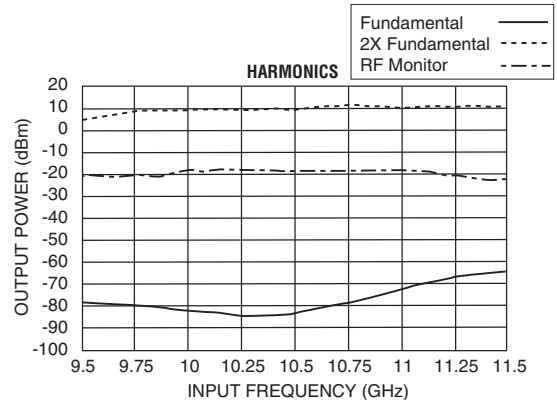

ACTIVE 2X FREQUENCY MULTIPLIER (CONT.)

MODEL: SYS2X1326

FEATURES

- Fundamental rejection -70 dBc
- Output power +16 dBm
- Packaging Hermetically sealed

ELECTRICAL SPECIFICATIONS

INPUT PARAMETERS	CONDITION	UNITS	MIN.	TYP.	MAX.
RF frequency range		GHz	10		13.25
RF VSWR	50 ohm reference	Ratio		2.5:1	
RF power range		dBm	+10		+12
V+ bias voltage	@ 250 mA max.	VDC	9		16
V- bias voltage	@ 15 mA max.	VDC	-9		-16
TRANSFER CHARACTERISTICS	CONDITION	UNITS	MIN.	TYP.	MAX.
Output power		dBm	+16		
Fundamental leakage	f_o 21–26.5 GHz	Input		-70	-50
	f_o 20–21.5 GHz			-40	-25
OUTPUT PARAMETERS	CONDITION	UNITS	MIN.	TYP.	MAX.
RF frequency range		GHz	20		26.5
RF VSWR	50 ohm reference	Ratio		2.5:1	

MAXIMUM RATINGS

Specification temperature +25°C
 Operating temperature -40 to +65°C
 Storage temperature -65 to +95°C

ADD SUFFIX TO

MODEL NO.

WG
S

OPTIONS

WR42 waveguide adaptor
Single positive supply

NOTE: Test data supplied at 25°C; fundamental rejection and output power.

OUTLINE DRAWING

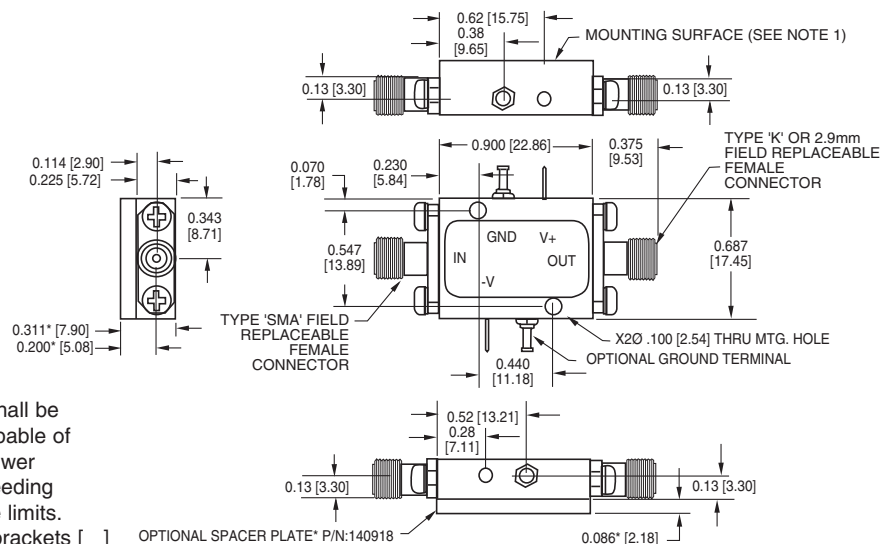

- NOTES: 1. Unit's mounting surface shall be attached to a heatsink capable of dissipating the device's power consumption without exceeding the operating temperature limits.
 2. All dimensions shown in brackets [] are in millimeters.

OPTIONAL SPACER PLATE* P/N:140918

ACTIVE 2X FREQUENCY MULTIPLIER (CONT.)

MODEL: SYS2X2040

FEATURES

- RF input..... 10 to 20 GHz
- RF output 20 to 40 GHz
- Packaging Hermetically sealed

ELECTRICAL SPECIFICATIONS

INPUT PARAMETERS	CONDITION	UNITS	MIN.	TYP.	MAX.
RF frequency range		GHz	10		20
RF VSWR	50 ohm reference	Ratio		3:1	
RF power range		dBm	+9		+13
V+ bias voltage	@ 250 mA max.	VDC	9		16
V- bias voltage	@ 15 mA max.	VDC	-9		-16
TRANSFER CHARACTERISTICS	CONDITION	UNITS	MIN.	TYP.	MAX.
Output power		dBm	+12	+15	
Fundamental leakage	Input	dBc		-16	-5
OUTPUT PARAMETERS	CONDITION	UNITS	MIN.	TYP.	MAX.
RF frequency range		GHz	20		40
RF VSWR	50 ohm reference	Ratio		2.75:1	
RF power		dBm		+15	

NOTE: Test data supplied at 25°C;
fundamental rejection and output power.

OUTLINE DRAWING

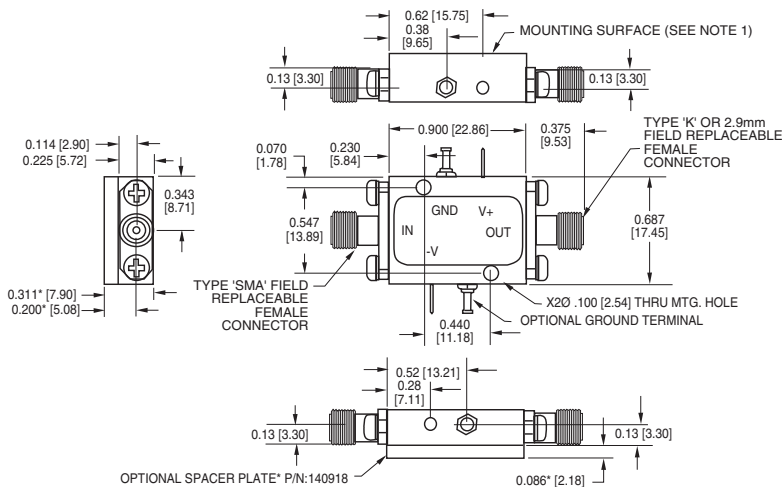

- NOTES: 1. Unit's mounting surface shall be attached to a heatsink capable of dissipating the devices power consumption without exceeding the operating temperature limits.
2. All dimensions shown in brackets [] are in millimeters.

MAXIMUM RATINGS

Specification temperature..... +25°C
Operating temperature -40 to +65°C
Storage temperature..... -65 to +95°C

ADD SUFFIX TO MODEL NO.

S

OPTION

Single positive supply

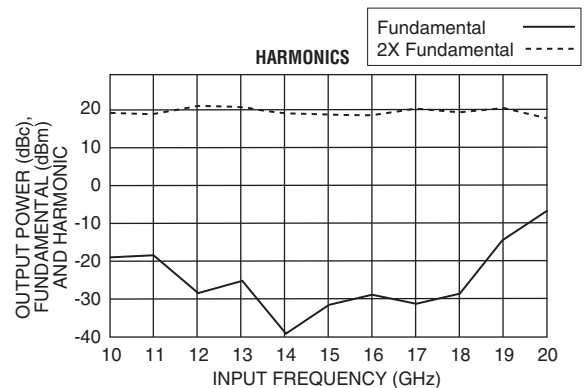

ACTIVE 2X FREQUENCY MULTIPLIER (CONT.)

MODEL: SYS2X1224

FEATURES

- High fundamental rejection..... -70 dBc
- Output power..... +10 dBm
- RF output monitor
- Packaging Hermetically sealed

ELECTRICAL SPECIFICATIONS

INPUT PARAMETERS	CONDITION	UNITS	MIN.	TYP.	MAX.
RF frequency range		GHz	11.24		13.24
RF VSWR	50 ohm reference	Ratio		2.5:1	
RF power range		dBm	-5		
V+ bias voltage	@ 250 mA max.	VDC	9		16
V- bias voltage	@ 15 mA max.	VDC	-9		-16
TRANSFER CHARACTERISTICS	CONDITION	UNITS	MIN.	TYP.	MAX.
Output power		dBm	+3	+10	
Fundamental leakage	Input	dBc		-70	-50
OUTPUT PARAMETERS	CONDITION	UNITS	MIN.	TYP.	MAX.
RF frequency range		GHz	22.48		26.48
RF VSWR	50 ohm reference	Ratio		2.5:1	
RF power		dBm	0		
RF monitor		dBm		-20	

NOTE: Test data supplied at 25°C;
fundamental rejection, output power and RF monitor.

MAXIMUM RATINGS

Specification temperature..... +25°C
Operating temperature -40 to +65°C
Storage temperature..... -65 to +95°C

OUTLINE DRAWING

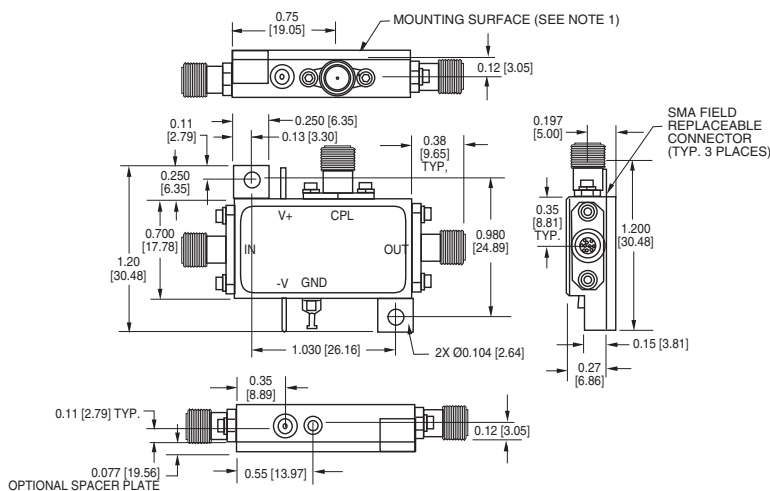

- NOTES: 1. Unit's mounting surface shall be attached to a heatsink capable of dissipating the devices power consumption without exceeding the operating temperature limits.
2. All dimensions shown in brackets [] are in millimeters.

ADD SUFFIX TO MODEL NO.

WG (WR42)
S

OPTIONS

WR42 output waveguide
Single positive supply

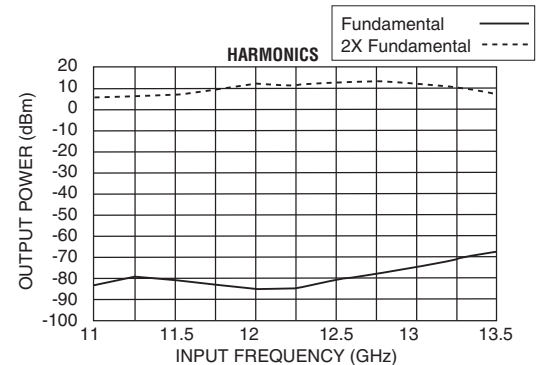

ACTIVE 2X FREQUENCY MULTIPLIER (CONT.)

MODEL: SYS2X2640WG

FEATURES

- Fundamental rejection -80 dBc
- Output power +15 dBm
- Packaging Hermetically sealed

ELECTRICAL SPECIFICATIONS

INPUT PARAMETERS	CONDITION	UNITS	MIN.	TYP.	MAX.
RF frequency range		GHz	13		20
RF VSWR	50 ohm reference	Ratio		2.5:1	
RF power range		dBm	+9		+13
V+ bias voltage	@ 250 mA max.	VDC	9		16
V- bias voltage	@ 15 mA max.	VDC	-9		-16
TRANSFER CHARACTERISTICS	CONDITION	UNITS	MIN.	TYP.	MAX.
Output power		dBm	+13	+15	
Fundamental leakage	Input	dBc		-80	-50
Third-harmonic leakage	Input	dBc		-30	-15
OUTPUT PARAMETERS	CONDITION	UNITS	MIN.	TYP.	MAX.
RF frequency range		GHz	26		40
RF VSWR	50 ohm reference	Ratio		2.5:1	
RF power		dBm		+15	

NOTE: Test data supplied at 25°C;
fundamental rejection and output power.

MAXIMUM RATINGS

Specification temperature +25°C
Operating temperature -40 to +65°C
Storage temperature -65 to +95°C

OUTLINE DRAWING

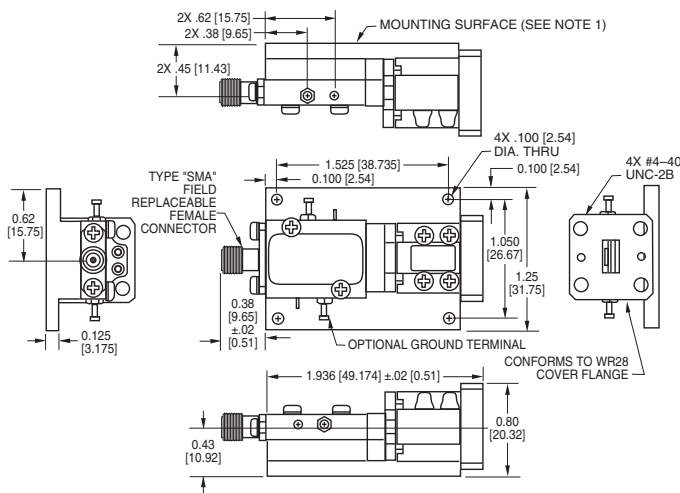

- NOTES: 1. Unit's mounting surface shall be attached to a heatsink capable of dissipating the devices power consumption without exceeding the operating temperature limits.
2. All dimensions shown in brackets [] are in millimeters.

ADD SUFFIX TO
MODEL NO.
S

OPTION
Single positive supply

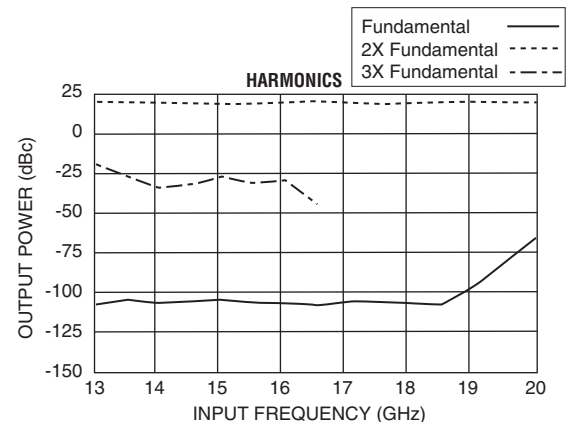

ACTIVE 2X FREQUENCY MULTIPLIER (CONT.)

MODEL: SYS2X1428

FEATURES

- High fundamental rejection..... -70 dBc
- Output power..... +17 dBm
- Packaging Hermetically sealed

ELECTRICAL SPECIFICATIONS

INPUT PARAMETERS	CONDITION	UNITS	MIN.	TYP.	MAX.
RF frequency range		GHz		14	
RF VSWR	50 ohm reference	Ratio		2.5:1	
RF power range		dBm		+12	
V+ bias voltage	@ 220 mA max.	VDC	9		16
V- bias voltage	@ 15 mA max.	VDC	-9		-16
TRANSFER CHARACTERISTICS	CONDITION	UNITS	MIN.	TYP.	MAX.
Output power		dBm	+14	+17	
Fundamental leakage	Input	dBc		-70	-60
Third-harmonic leakage	Input	dBc		-60	
OUTPUT PARAMETERS	CONDITION	UNITS	MIN.	TYP.	MAX.
RF frequency range		GHz		28	
RF VSWR	50 ohm reference	Ratio		2.5:1	

NOTE: Test data supplied at 25°C;
fundamental rejection and output power.

OUTLINE DRAWING

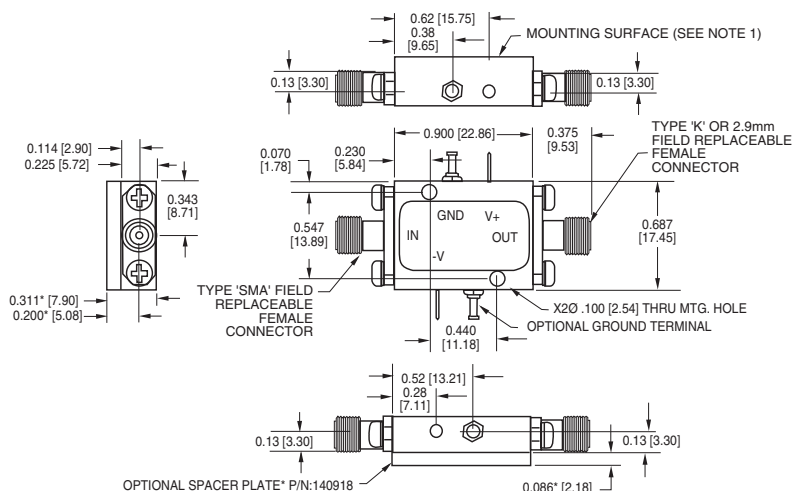

- NOTES: 1. Unit's mounting surface shall be attached to a heatsink capable of dissipating the devices power consumption without exceeding the operating temperature limits.
2. All dimensions shown in brackets [] are in millimeters.

MAXIMUM RATINGS

Specification temperature..... +25°C
Operating temperature -40 to +65°C
Storage temperature..... -65 to +95°C

ADD SUFFIX TO MODEL NO.

WG (WR28)
S
VH

OPTIONS

WR28 output waveguide
Single positive supply
Very high fundamental rejection (80 dBc)

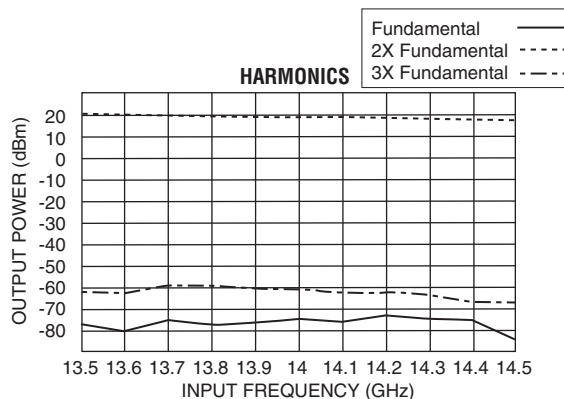

ACTIVE 2X FREQUENCY MULTIPLIER (CONT.)

MODEL: SYS2X1530

FEATURES

- High fundamental rejection..... -90 dBc
- Output power..... +20 dBm
- RF output monitor
- Packaging Hermetically sealed

ELECTRICAL SPECIFICATIONS

INPUT PARAMETERS	CONDITION	UNITS	MIN.	TYP.	MAX.
RF frequency range		GHz		15	
RF VSWR	50 ohm reference	Ratio		2.5:1	
RF power range		dBm	-20		
V+ bias voltage	@ 450 mA max.	VDC	9		16
V- bias voltage	@ 15 mA max.	VDC	-9		-16
TRANSFER CHARACTERISTICS	CONDITION	UNITS	MIN.	TYP.	MAX.
Output power		dBm	+18	+20	
Fundamental leakage	Input	dBc		-90	-75
Third-harmonic leakage	Input	dBc		-80	
OUTPUT PARAMETERS	CONDITION	UNITS	MIN.	TYP.	MAX.
RF frequency range		GHz		30	
RF VSWR	50 ohm reference	Ratio		2.5:1	
RF monitor		dBm		-2	

NOTE: Test data supplied at 25°C;
fundamental rejection, output power and RF monitor.

MAXIMUM RATINGS

Specification temperature..... +25°C
Operating temperature -40 to +65°C
Storage temperature..... -65 to +95°C

OUTLINE DRAWING

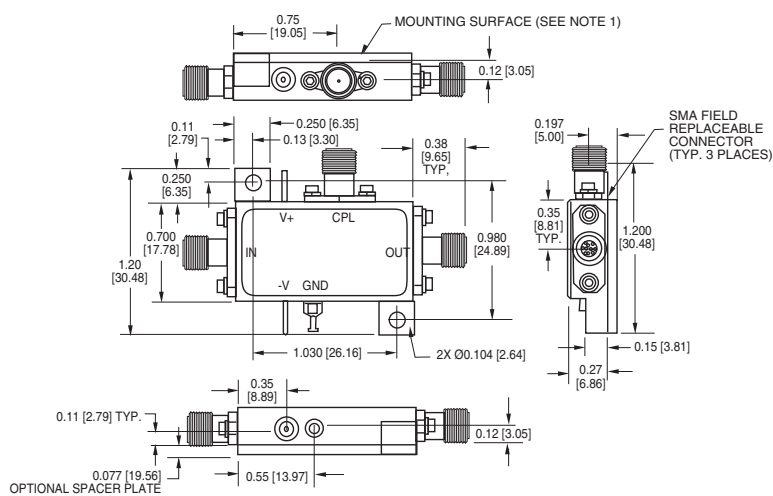

NOTES: 1. Unit's mounting surface shall be attached to a heatsink capable of dissipating the devices power consumption without exceeding the operating temperature limits.
2. All dimensions shown in brackets [] are in millimeters.

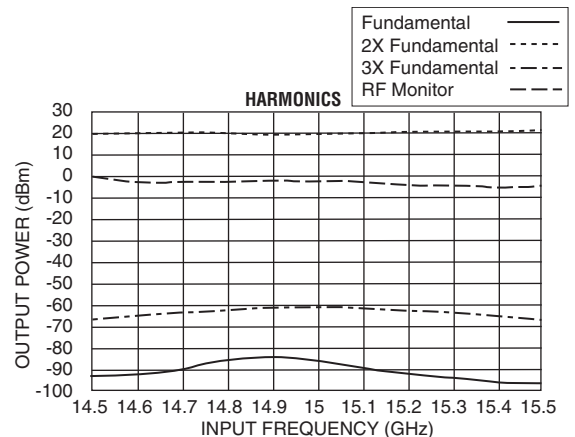

ACTIVE 2X FREQUENCY MULTIPLIER (CONT.)

MODEL: SYS2X1734

FEATURES

- High fundamental rejection..... -50 dBc
- Output power..... +18 dBm
- Packaging Hermetically sealed

ELECTRICAL SPECIFICATIONS

INPUT PARAMETERS	CONDITION	UNITS	MIN.	TYP.	MAX.
RF frequency range		GHz	16	17	17.5
RF VSWR	50 ohm reference	Ratio		2.5:1	
RF power range		dBm		+12	
V+ bias voltage	@ 250 mA max.	VDC	9		16
V- bias voltage	@ 15 mA max.	VDC	-9		-16
TRANSFER CHARACTERISTICS	CONDITION	UNITS	MIN.	TYP.	MAX.
Output power		dBm	+13	+18	
Fundamental leakage	Input	dBc		-50	
OUTPUT PARAMETERS	CONDITION	UNITS	MIN.	TYP.	MAX.
RF frequency range		GHz	32	34	35
RF VSWR	50 ohm reference	Ratio		2.5:1	

NOTE: Test data supplied at 25°C;
fundamental rejection and output power.

OUTLINE DRAWING

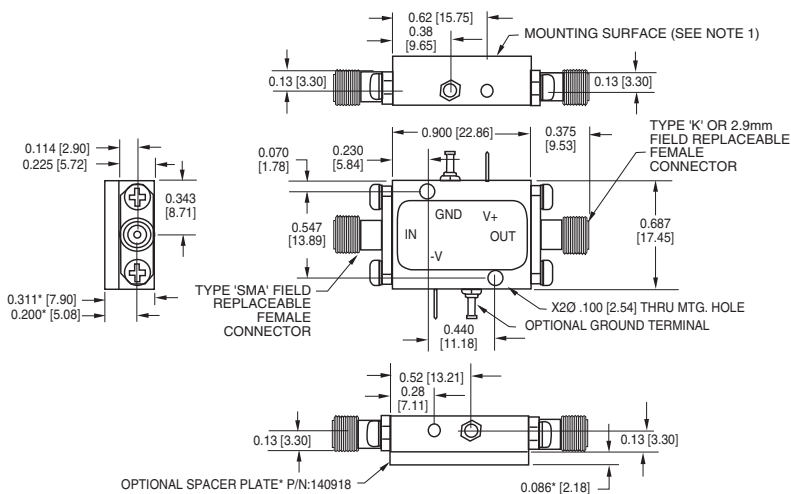

- NOTES: 1. Unit's mounting surface shall be attached to a heatsink capable of dissipating the devices power consumption without exceeding the operating temperature limits.
2. All dimensions shown in brackets [] are in millimeters.

MAXIMUM RATINGS

Specification temperature..... +25°C
Operating temperature -40 to +65°C
Storage temperature..... -65 to +95°C

ADD SUFFIX TO MODEL NO.

WG
S

OPTIONS

WR28 output waveguide
Single positive supply

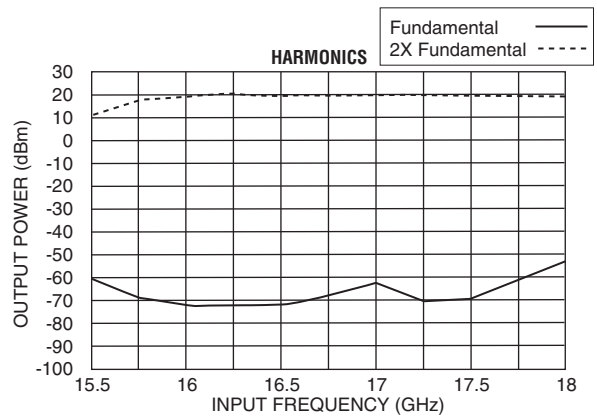

ACTIVE 2X FREQUENCY MULTIPLIER (CONT.)

MODEL: SYS2X1735

FEATURES

- High fundamental rejection..... -70 dBc
- Output power..... +18 dBm
- RF output monitor
- Packaging Hermetically sealed

ELECTRICAL SPECIFICATIONS

INPUT PARAMETERS	CONDITION	UNITS	MIN.	TYP.	MAX.
RF frequency range		GHz		17.5	
RF VSWR	50 ohm reference	Ratio		2.5:1	
RF power range		dBm	-20		
V+ bias voltage	@ 450 mA max.	VDC	9		16
V- bias voltage	@ 15 mA max.	VDC	-9		-16
TRANSFER CHARACTERISTICS	CONDITION	UNITS	MIN.	TYP.	MAX.
Output power		dBm	+18		
Fundamental leakage	Input	dBc		-70	-50
OUTPUT PARAMETERS	CONDITION	UNITS	MIN.	TYP.	MAX.
RF frequency range		GHz		35	
RF VSWR	50 ohm reference	Ratio		2.5:1	
RF monitor		dBm		-2	

NOTE: Test data supplied at 25°C;
fundamental rejection, output power and RF monitor.

OUTLINE DRAWING

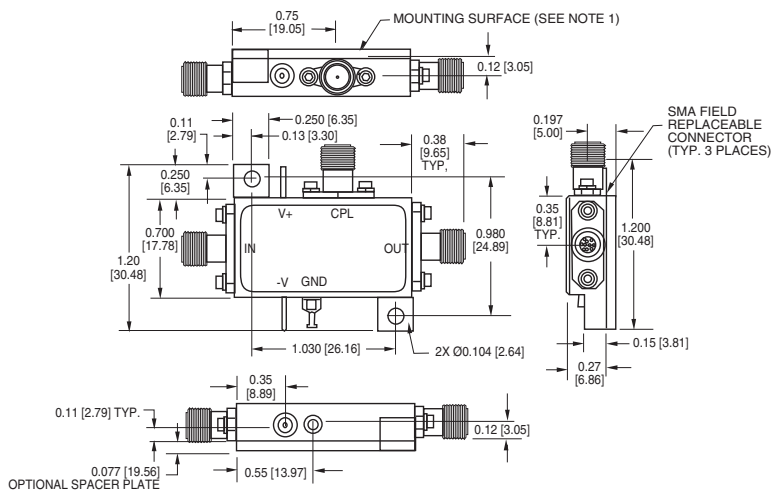

- NOTES: 1. Unit's mounting surface shall be attached to a heatsink capable of dissipating the devices power consumption without exceeding the operating temperature limits.
2. All dimensions shown in brackets [] are in millimeters.

MAXIMUM RATINGS

Specification temperature..... +25°C
Operating temperature -40 to +65°C
Storage temperature..... -65 to +95°C

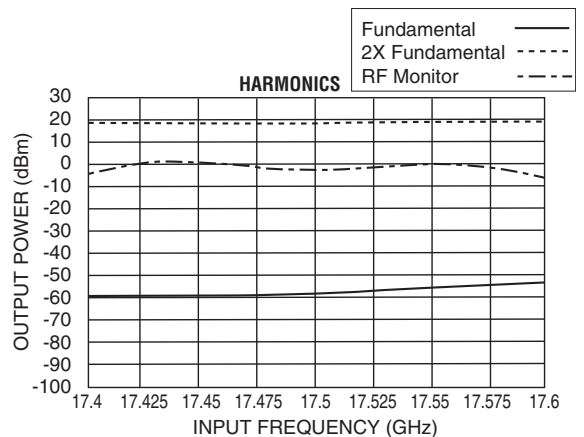

ACTIVE FREQUENCY TRIPLERS

MODEL: SYS3J042072

ELECTRICAL SPECIFICATIONS

Input frequency range	1.4 – 2.4 GHz
Output frequency range	4.2 – 7.2 GHz
Input power range	4 dBm
Output level	+12 dB typical
Harmonic rejection	
Input	-20 dB typical
Output	-15 dB typical
Input, output VSWR	2.5:1 typical
DC voltage/current	+5/150

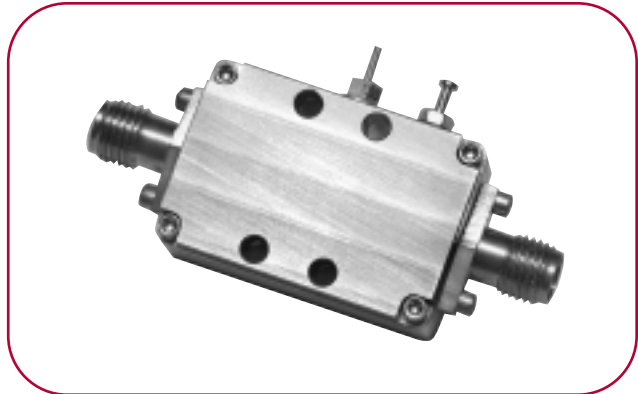

OUTPUT POWER VS. FREQUENCY
($P_{IN} = +10$ dBm)

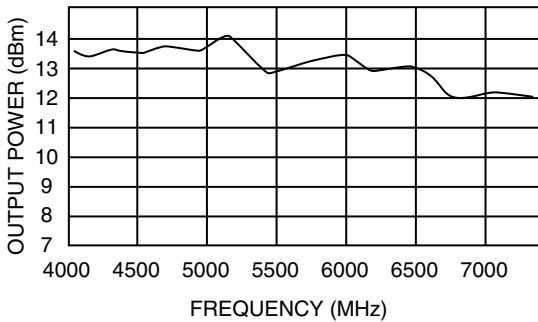

HARMONIC REJECTION

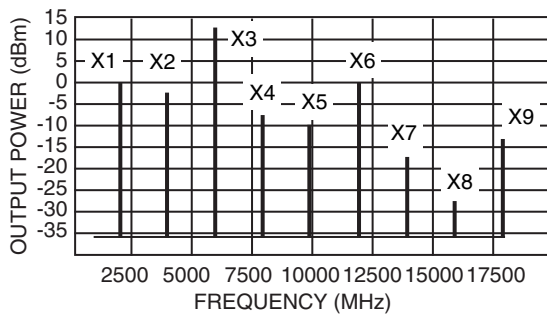

OUTLINE DRAWING

157637

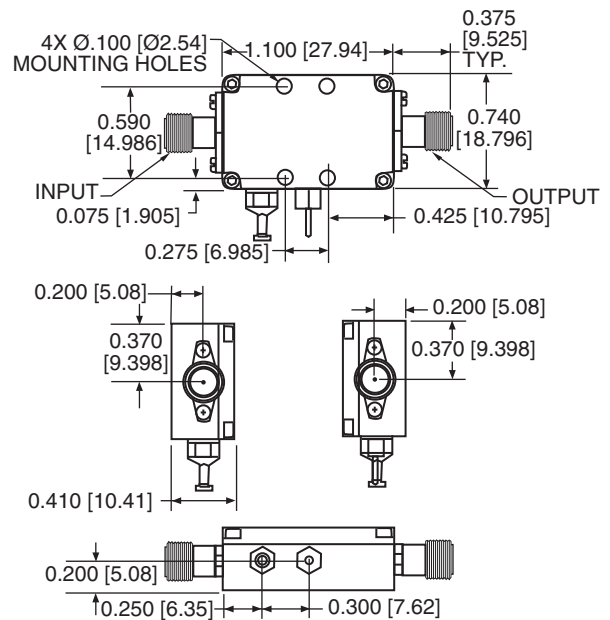

NOTE:

1. All dimensions shown in brackets [] are in millimeters.

ACTIVE FREQUENCY TRIPLERS (CONT.)

MODEL: SYS02J

ELECTRICAL SPECIFICATIONS

Input frequency range	1.4 – 2.4 GHz
Output frequency range	4.2 – 7.2 GHz
Input power range	4 dBm
Output level	+12 dB typical minimum
Harmonic rejection	
Input	-20 dB typical
Output	-15 dB typical
Input, output VSWR	2.5:1 typical
DC voltage/current	+5/150

FUNCTIONAL BLOCK DIAGRAM

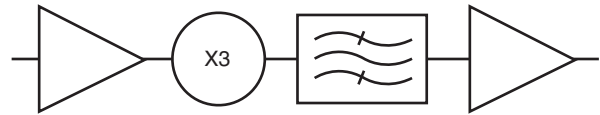

OUTPUT POWER VS. FREQUENCY
($P_{IN} = +10$ dBm)

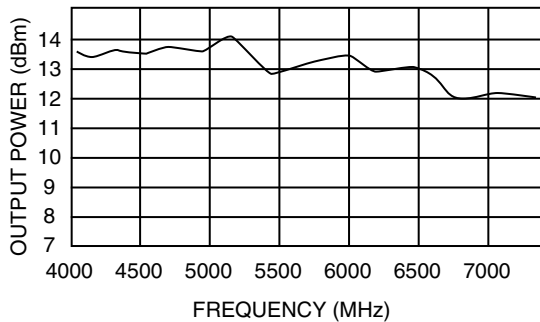

HARMONIC REJECTION

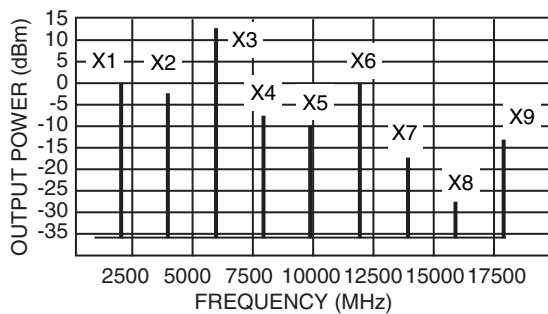

OUTLINE DRAWING

160212

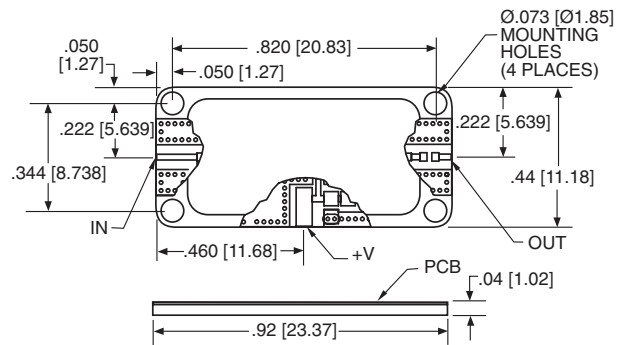

NOTE:

1. All dimensions shown in brackets [] are in millimeters.

PASSIVE FREQUENCY TRIPLERS

MODEL: MX3M320400

ELECTRICAL SPECIFICATIONS

Input frequency range	10.66 – 13.33 GHz
Output frequency range	32 – 40 GHz
Input power range	8 – 12 dBm
Harmonic rejection	
Fundamental	-55 dBc typical
Odd harmonic	-55 dBc typical

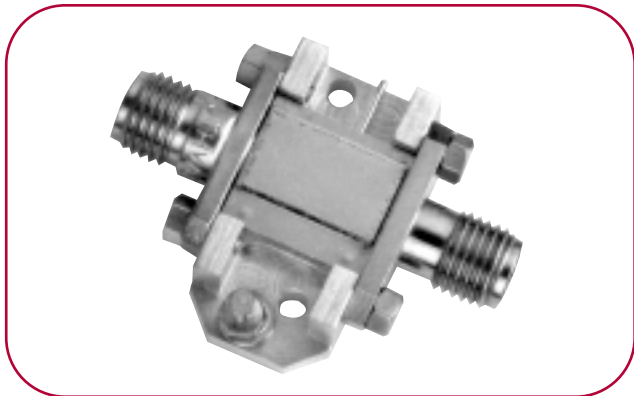

OUTPUT POWER VS. FREQUENCY

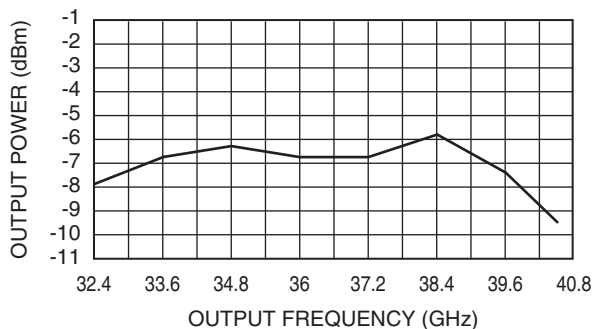

FUNDAMENTAL HARMONIC REJECTION VS. FREQUENCY

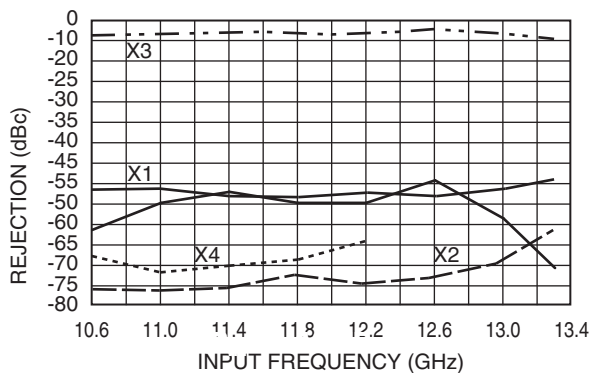

OUTLINE DRAWING

MXF

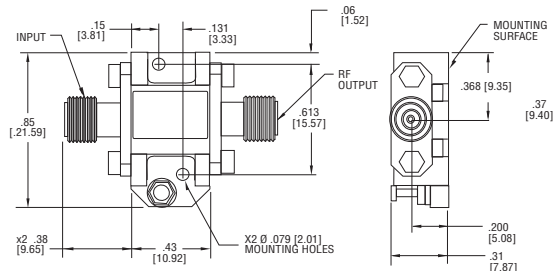

NOTES:

- Optional input connectors SMA, K or output connectors K, V or GPO type male.
- Optional waveguide output available, please contact MITEQ.
- All dimensions shown in brackets [] are in millimeters.

ACTIVE 3X FREQUENCY MULTIPLIER

MODEL: SYS3X2327

FEATURES

- High fundamental rejection..... -50 dBc
- Output power..... +10 dBm
- Packaging Hermetically sealed

ELECTRICAL SPECIFICATIONS

INPUT PARAMETERS	CONDITION	UNITS	MIN.	TYP.	MAX.
RF frequency range		GHz	7.66		9
RF VSWR	50 ohm reference	Ratio		2.5:1	
RF power range		dBm	+3		
V+ bias voltage	@ 180 mA max.	VDC	9		16
TRANSFER CHARACTERISTICS	CONDITION	UNITS	MIN.	TYP.	MAX.
Output power		dBm	+7	+10	
Fundamental leakage	Input	dBc		-50	-30
Second-harmonic leakage	Input	dBc		-35	-15
Fourth-harmonic leakage	Input	dBc		-35	-5
OUTPUT PARAMETERS	CONDITION	UNITS	MIN.	TYP.	MAX.
RF frequency range		GHz	23		27
RF VSWR	50 ohm reference	Ratio		2.5:1	

NOTE: Test data supplied at 25°C; fundamental rejection, output power, second- and fourth-harmonic suppression.

MAXIMUM RATINGS

Specification temperature..... +25°C
 Operating temperature -40 to +65°C
 Storage temperature..... -65 to +95°C

OUTLINE DRAWING

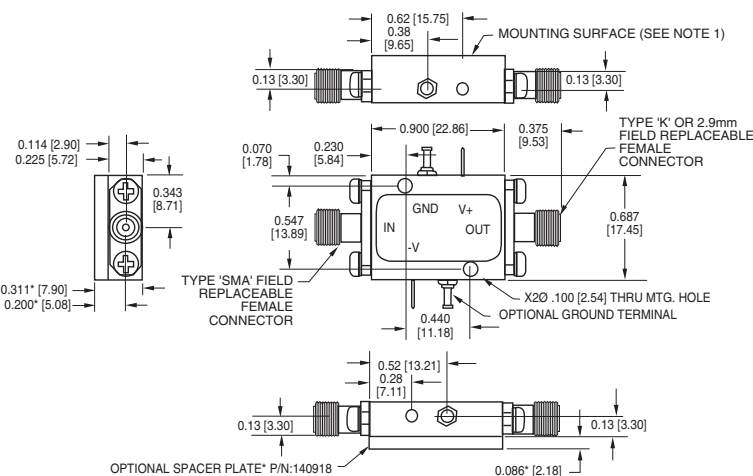

- NOTES: 1. Unit's mounting surface shall be attached to a heatsink capable of dissipating the devices power consumption without exceeding the operating temperature limits.
 2. All dimensions shown in brackets [] are in millimeters.

ADD SUFFIX TO MODEL NO.

WG (WR42)
 S

OPTIONS

WR42 output waveguide
 Single positive supply

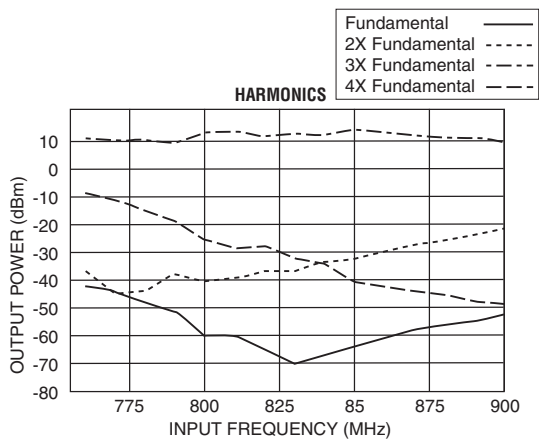

ACTIVE 3X FREQUENCY MULTIPLIER (CONT.)

MODEL: SYS3X3334

FEATURES

- High fundamental rejection -80 dBc
- High output power +23 dBm
- Packaging Hermetically sealed

ELECTRICAL SPECIFICATIONS

INPUT PARAMETERS	CONDITION	UNITS	MIN.	TYP.	MAX.
RF frequency range		GHz	11.1		11.6
RF VSWR	50 ohm reference	Ratio		2:1	
RF power range		dBm	+15		
V+ bias voltage	@ 320 mA max.	VDC	9		16
V- bias voltage	@ 25 mA max.	VDC	-9		-16
TRANSFER CHARACTERISTICS	CONDITION	UNITS	MIN.	TYP.	MAX.
Output power		dBm	+21	+23	
Fundamental leakage	Input	dBc		-80	-70
Second-harmonic leakage	Input	dBc		-80	-60
OUTPUT PARAMETERS	CONDITION	UNITS	MIN.	TYP.	MAX.
RF frequency range		GHz	33.3		34.8
RF VSWR	50 ohm reference	Ratio		2:1	

NOTE: Test data supplied at 25°C;
fundamental rejection and output power.

OUTLINE DRAWING

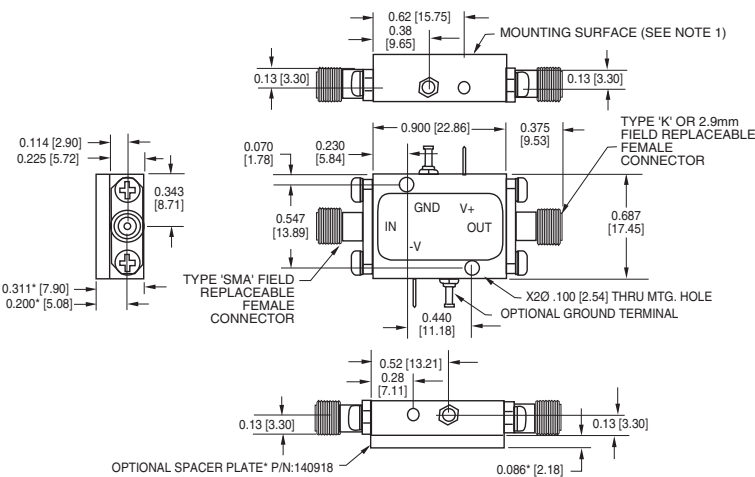

- NOTES: 1. Unit's mounting surface shall be attached to a heatsink capable of dissipating the devices power consumption without exceeding the operating temperature limits.
2. All dimensions shown in brackets [] are in millimeters.

MAXIMUM RATINGS

Specification temperature +25°C
Operating temperature -40 to +65°C
Storage temperature -65 to +95°C

ADD SUFFIX TO MODEL NO.

WG
S

OPTIONS

WR28 output waveguide
Single positive supply

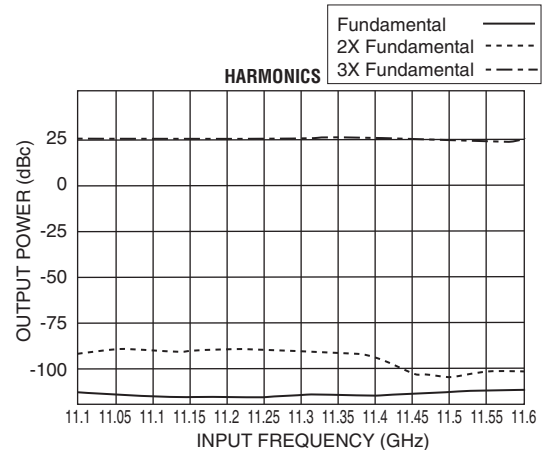

ACTIVE 3X FREQUENCY MULTIPLIER (CONT.)

MODEL: SYS3X3550WG

FEATURES

- High fundamental rejection..... -90 dBc
- Output power..... +14.5 dBm
- Packaging Hermetically sealed

ELECTRICAL SPECIFICATIONS

INPUT PARAMETERS	CONDITION	UNITS	MIN.	TYP.	MAX.
RF frequency range		GHz	11.8		11.9
RF VSWR	50 ohm reference	Ratio		2:1	
RF power range		dBm	+13		
V+ bias voltage	@ 300 mA max.	VDC		15	
V- bias voltage	@ 20 mA max.	VDC		-15	
TRANSFER CHARACTERISTICS	CONDITION	UNITS	MIN.	TYP.	MAX.
Output power		dBm	+14.5		
Fundamental leakage	Input	dBc		-90	
Second-harmonic leakage	Input	dBc		-65	-55
OUTPUT PARAMETERS	CONDITION	UNITS	MIN.	TYP.	MAX.
RF frequency range		GHz	35.4		35.7
RF VSWR	50 ohm reference	Ratio		2:1	

NOTE: Test data supplied at 25°C;
leakage at 1X and 2X output power.

OUTLINE DRAWING

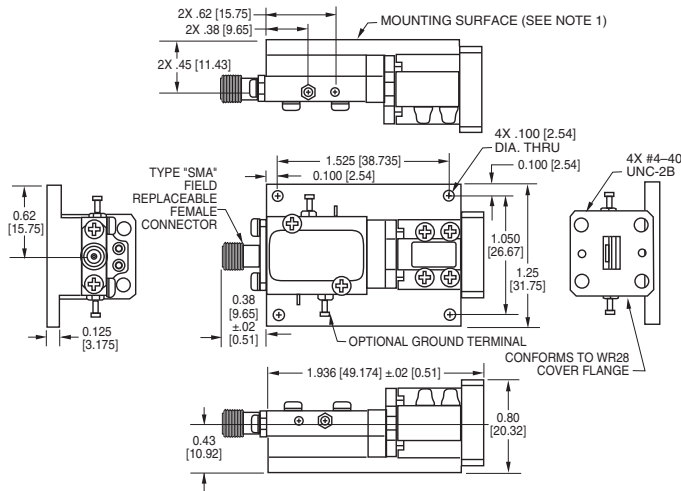

- NOTES: 1. Unit's mounting surface shall be attached to a heatsink capable of dissipating the devices power consumption without exceeding the operating temperature limits.
2. All dimensions shown in brackets [] are in millimeters.

MAXIMUM RATINGS

Specification temperature..... +25°C
Operating temperature -40 to +65°C
Storage temperature..... -65 to +95°C

ADD SUFFIX TO
MODEL NO.
S

OPTION
Single positive supply

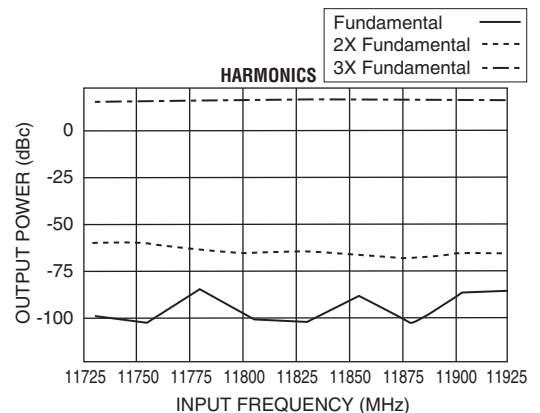

ACTIVE 3X FREQUENCY MULTIPLIER (CONT.)

MODEL: SYS3X3637

FEATURES

- High fundamental rejection..... -60 dBc
- Output power..... +15 dBm
- Packaging Hermetically sealed

ELECTRICAL SPECIFICATIONS

INPUT PARAMETERS	CONDITION	UNITS	MIN.	TYP.	MAX.
RF frequency range		GHz	12.2		12.5
RF VSWR	50 ohm reference	Ratio		2.1:1	
RF power range		dBm		+13	
V+ bias voltage	@ 200 mA max.	VDC	9		15
V- bias voltage	@ 20 mA max.	VDC	-9		-15
TRANSFER CHARACTERISTICS	CONDITION	UNITS	MIN.	TYP.	MAX.
Output power		dBm	+12	+15	
Fundamental leakage	Input	dBc		-60	-50
Second-harmonic leakage	Input	dBc		-70	
Fourth-harmonic leakage	Input	dBc		-55	
OUTPUT PARAMETERS	CONDITION	UNITS	MIN.	TYP.	MAX.
RF frequency range		GHz	36.6		37.65
RF VSWR	50 ohm reference	Ratio		2.1:1	

NOTE: Test data supplied at 25°C; fundamental rejection, output power and second-harmonic leakage.

MAXIMUM RATINGS

Specification temperature..... +25°C
 Operating temperature -40 to +65°C
 Storage temperature..... -65 to +95°C

OUTLINE DRAWING

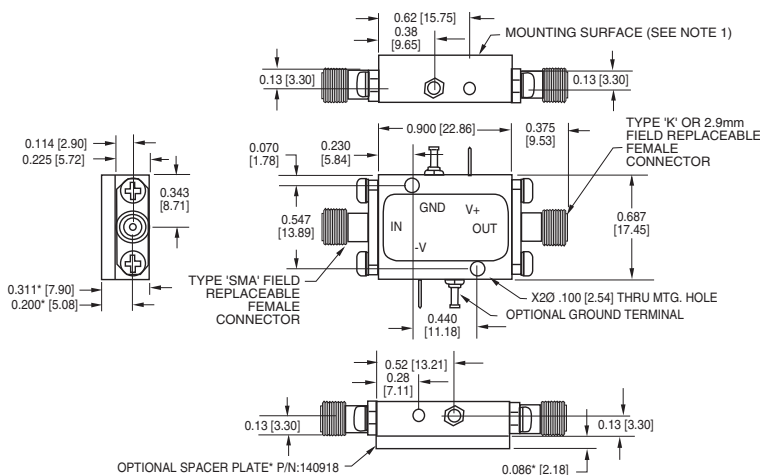

- NOTES: 1. Unit's mounting surface shall be attached to a heatsink capable of dissipating the devices power consumption without exceeding the operating temperature limits.
 2. All dimensions shown in brackets [] are in millimeters.

ADD SUFFIX TO MODEL NO.

WG
S

OPTIONS

WR28 output waveguide
Single positive supply

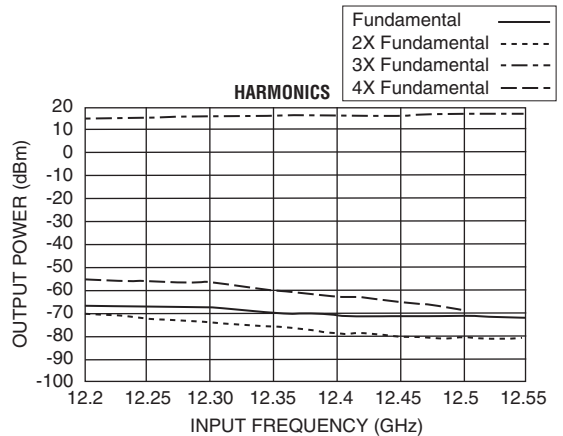

ACTIVE 3X FREQUENCY MULTIPLIER (CONT.)

MODEL: SYS3X3738

FEATURES

- High fundamental rejection..... -70 dBc
- Output power..... +16 dBm
- Packaging Hermetically sealed

ELECTRICAL SPECIFICATIONS

INPUT PARAMETERS	CONDITION	UNITS	MIN.	TYP.	MAX.
RF frequency range		GHz	12.5		12.9
RF VSWR	50 ohm reference	Ratio		2.1:1	
RF power range		dBm		+13	
V+ bias voltage	@ 200 mA max.	VDC	9		16
V- bias voltage	@ 20 mA max.	VDC	-9		-16
TRANSFER CHARACTERISTICS	CONDITION	UNITS	MIN.	TYP.	MAX.
Output power		dBm	+12	+16	
Fundamental leakage	Input	dBc		-70	-50
Second-harmonic leakage	Input	dBc		-75	
OUTPUT PARAMETERS	CONDITION	UNITS	MIN.	TYP.	MAX.
RF frequency range		GHz	37		38
RF VSWR	50 ohm reference	Ratio		2.1:1	

NOTE: Test data supplied at 25°C; fundamental rejection, output power and second-harmonic leakage.

OUTLINE DRAWING

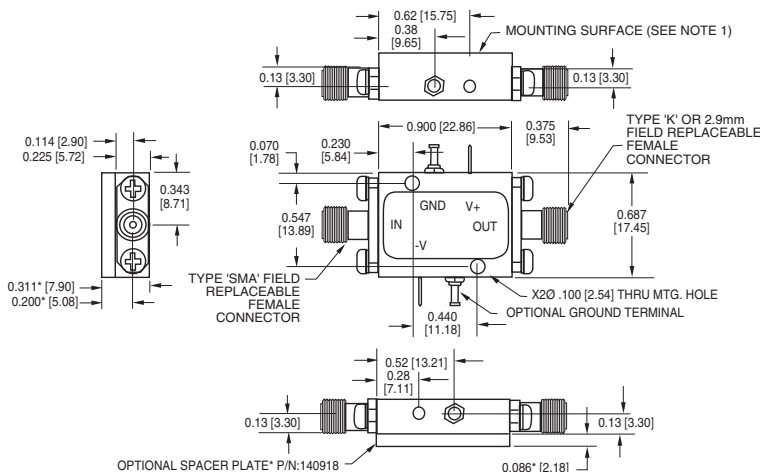

- NOTES: 1. Unit's mounting surface shall be attached to a heatsink capable of dissipating the devices power consumption without exceeding the operating temperature limits.
 2. All dimensions shown in brackets [] are in millimeters.

MAXIMUM RATINGS

Specification temperature..... +25°C
 Operating temperature -40 to +65°C
 Storage temperature..... -65 to +95°C

ADD SUFFIX TO MODEL NO.

WG (WR28)
 S

OPTIONS

WR28 output waveguide
 Single positive supply

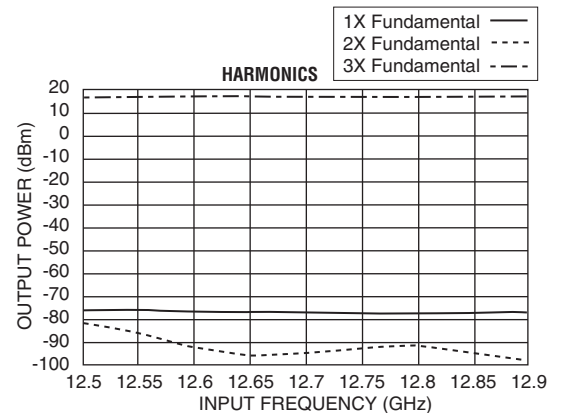

ACTIVE 3X FREQUENCY MULTIPLIER (CONT.)

MODEL: SYS3X3842

FEATURES

- High fundamental rejection..... -70 dBc
- Output power..... +16 dBm
- Packaging Hermetically sealed

ELECTRICAL SPECIFICATIONS

INPUT PARAMETERS	CONDITION	UNITS	MIN.	TYP.	MAX.
RF frequency range		GHz	12.6		14
RF VSWR	50 ohm reference	Ratio		2.5:1	
RF power range		dBm	+12		
V+ bias voltage	@ 200 mA max.	VDC	9		16
V- bias voltage	@ 15 mA max.	VDC	-9		-16
TRANSFER CHARACTERISTICS	CONDITION	UNITS	MIN.	TYP.	MAX.
Output power		dBm	+15	+16	
Fundamental leakage	Input	dBc		-70	-60
Second-harmonic leakage	Input	dBc		-70	-60
OUTPUT PARAMETERS	CONDITION	UNITS	MIN.	TYP.	MAX.
RF frequency range		GHz	38		42
RF VSWR	50 ohm reference	Ratio		2.5:1	

NOTE: Test data supplied at 25°C; fundamental rejection and output power.

OUTLINE DRAWING

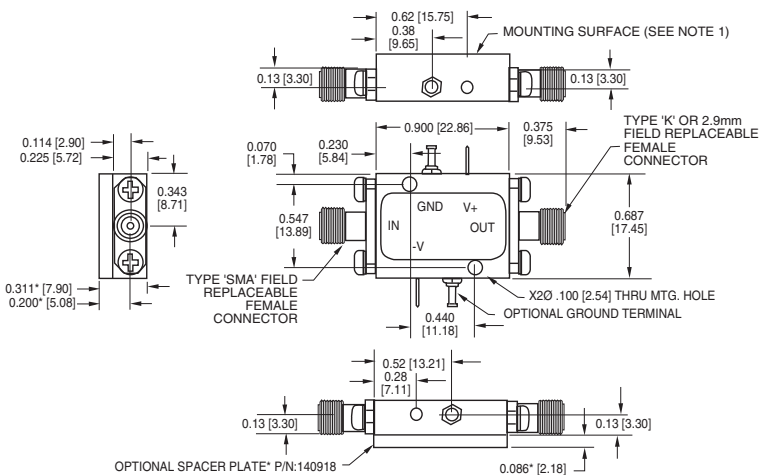

- NOTES: 1. Unit's mounting surface shall be attached to a heatsink capable of dissipating the devices power consumption without exceeding the operating temperature limits.
 2. All dimensions shown in brackets [] are in millimeters.

MAXIMUM RATINGS

Specification temperature..... +25°C
 Operating temperature -40 to +65°C
 Storage temperature..... -65 to +95°C

ADD SUFFIX TO MODEL NO.

WG
S

OPTIONS

WR28 waveguide adaptor
 Single positive supply

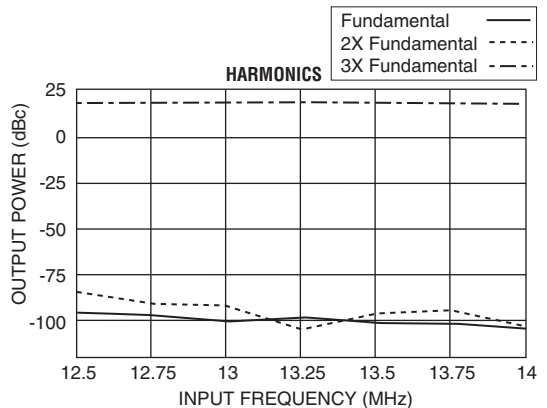

ACTIVE 3X FREQUENCY MULTIPLIER (CONT.)

MODEL: SYS3X1442

FEATURES

- High fundamental rejection..... -80 dBc
- Output power..... +16 dBm
- Packaging Hermetically sealed

ELECTRICAL SPECIFICATIONS

INPUT PARAMETERS	CONDITION	UNITS	MIN.	TYP.	MAX.
RF frequency range		GHz		14	
RF VSWR	50 ohm reference	Ratio		2.5:1	
RF power range		dBm		+12	
V+ bias voltage	@ 180 mA max.	VDC	9		16
V- bias voltage	@ 15 mA max.	VDC	-9		-16
TRANSFER CHARACTERISTICS	CONDITION	UNITS	MIN.	TYP.	MAX.
Output power		dBm	+14	+16	
Fundamental leakage	Input	dBc		-80	-60
Second-harmonic leakage	Input	dBc		-80	-60
OUTPUT PARAMETERS	CONDITION	UNITS	MIN.	TYP.	MAX.
RF frequency range		GHz		42	
RF VSWR	50 ohm reference	Ratio		2.75:1	

NOTE: Test data supplied at 25°C; fundamental rejection, output power and second-harmonic leakage.

OUTLINE DRAWING

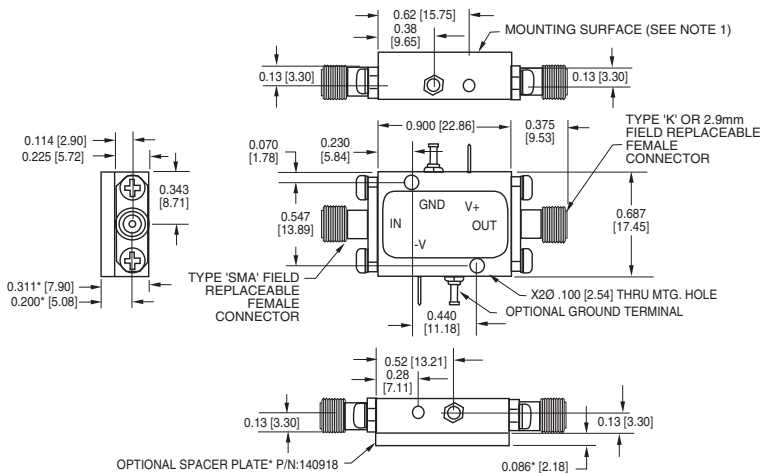

- NOTES: 1. Unit's mounting surface shall be attached to a heatsink capable of dissipating the devices power consumption without exceeding the operating temperature limits.
 2. All dimensions shown in brackets [] are in millimeters.

MAXIMUM RATINGS

Specification temperature..... +25°C
 Operating temperature -40 to +65°C
 Storage temperature..... -65 to +95°C

ADD SUFFIX TO MODEL NO.

WG (WR22)
 S
 VH

OPTIONS

WR22 output waveguide
 Single positive supply
 Very high fundamental rejection (80 dBc)

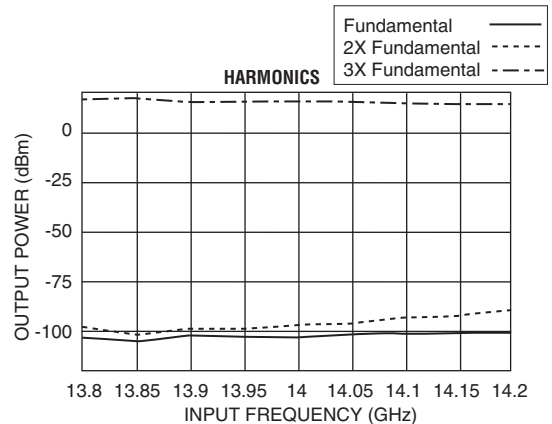

ACTIVE 4X FREQUENCY MULTIPLIER

MODEL: SYS4X1146

FEATURES

- High fundamental rejection..... -60 dBc
- Output power..... +16 dBm
- Packaging Hermetically sealed

ELECTRICAL SPECIFICATIONS

INPUT PARAMETERS	CONDITION	UNITS	MIN.	TYP.	MAX.
RF frequency range		GHz	10.25		11.5
RF VSWR	50 ohm reference	Ratio		2.5:1	
RF power range		dBm		+12	
V+ bias voltage	@ 180 mA max.	VDC	9		16
V- bias voltage	@ 15 mA max.	VDC	-9		-16
TRANSFER CHARACTERISTICS	CONDITION	UNITS	MIN.	TYP.	MAX.
Output power		dBm	+13	+16	
Fundamental leakage	Input	dBc		-60	
Second-harmonic leakage	Input	dBc			
Third-harmonic leakage	Input	dBc		-45	
OUTPUT PARAMETERS	CONDITION	UNITS	MIN.	TYP.	MAX.
RF frequency range		GHz	41		46
RF VSWR	50 ohm reference	Ratio		2.75:1	

NOTE: Test data supplied at 25°C;
fundamental rejection and output power.

MAXIMUM RATINGS

Specification temperature..... +25°C
Operating temperature -40 to +65°C
Storage temperature..... -65 to +95°C

OUTLINE DRAWING

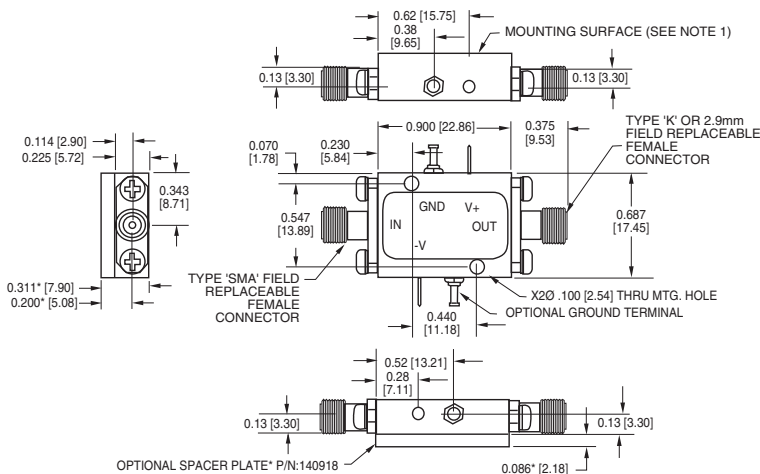

- NOTES: 1. Unit's mounting surface shall be attached to a heatsink capable of dissipating the devices power consumption without exceeding the operating temperature limits.
2. All dimensions shown in brackets [] are in millimeters.

ACTIVE 5X FREQUENCY MULTIPLIER

MODEL: SYS5J100100

FEATURES

- High fundamental rejection..... -70 dBc
- Output power..... +10 dBm
- Packaging Hermetically sealed

ELECTRICAL SPECIFICATIONS

INPUT PARAMETERS	CONDITION	UNITS	MIN.	TYP.	MAX.
RF frequency range		GHz		2	
RF VSWR	50 ohm reference	Ratio		2.5:1	
RF power range		dBm	+10		
V+ bias voltage	@ 250 mA typ.	VDC	+15		
TRANSFER CHARACTERISTICS	CONDITION	UNITS	MIN.	TYP.	MAX.
Output power		dBm	+10		
Fundamental leakage	Input	dBc		-70	-50
Harmonic leakage	Input	dBc		-70	-50
Spurious	980–1020 MHz	dBc		-80	-60
OUTPUT PARAMETERS	CONDITION	UNITS	MIN.	TYP.	MAX.
RF frequency range		GHz		10	
RF VSWR	50 ohm reference	Ratio		2:1	

NOTE: Test data supplied at 25°C;
fundamental and harmonic leakage and output power.

MAXIMUM RATINGS

Specification temperature..... +25°C
Operating temperature 0 to +40°C
Storage temperature..... -65 to +125°C

OUTLINE DRAWING

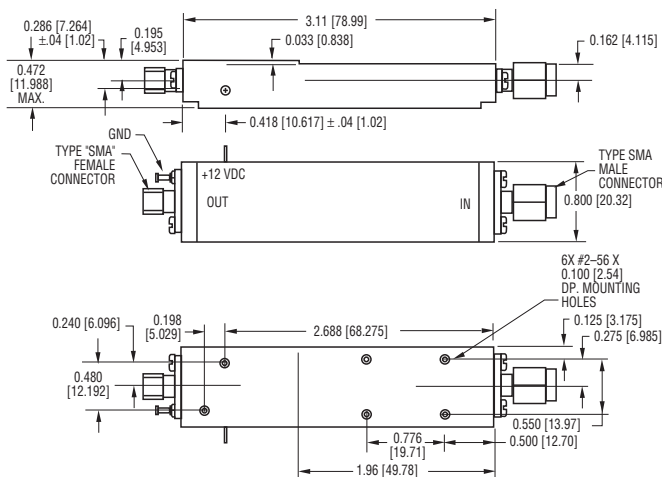

- NOTES: 1. Unit's mounting surface shall be attached to a heatsink capable of dissipating the devices power consumption without exceeding the operating temperature limits.
2. All dimensions shown in brackets [] are in millimeters.

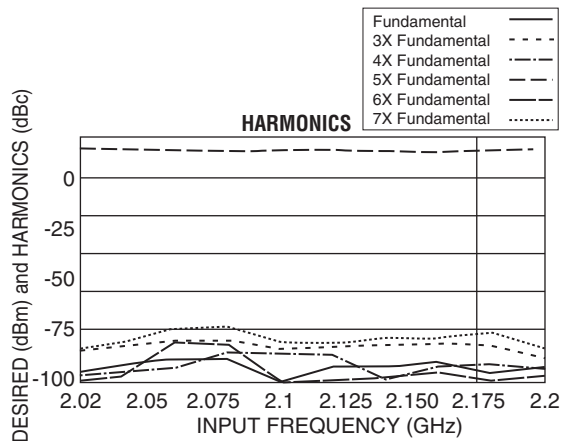

0.15 TO 3 GHz, (X20) MULTIPLIER SUBSYSTEM

MODEL: SYS20M028032

FEATURES

- Input/output frequency 0.15/3 GHz
- Input/output BW 10 percent
- Spurious (octave BW)..... -55 dBc
- Power output +5 dBm
- Noise output -55 dBm/MHz

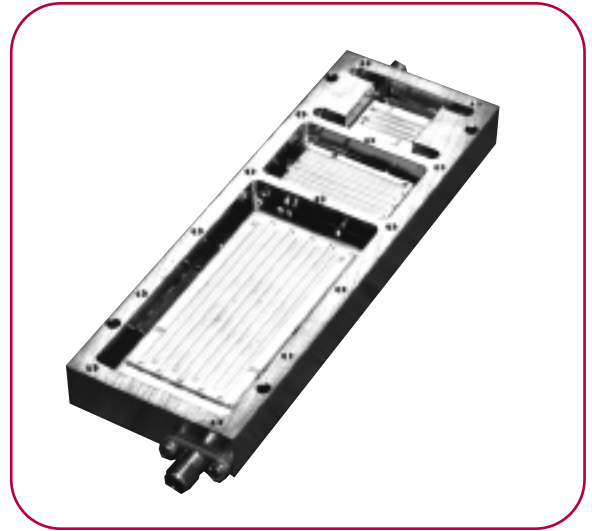

This integrated 3 stage, (X20) active multiplier subsystem is suitable for receiver LO generation using a reference VHF stabilized or voltage-tuned input source. Industry standard size amplifier and multiplier modules are used internally to make the unit easily modified for custom frequencies. These microstrip multiplier modules (“FEM” and “FOM” series) are also available as individual “drop-in” components. Intermediate outputs at X5 and X10 are available as an option as well.

ELECTRICAL SPECIFICATIONS

INPUT PARAMETERS	CONDITION	UNITS	MIN.	TYP.	MAX.
RF frequency range		MHz	142	150	158
RF power range		dBm	+10		+13
RF VSWR		Ratio		1.5:1	
DC power	@ +15 volts	mA		170	
TRANSFER CHARACTERISTICS	CONDITION	UNITS	MIN.	TYP.	MAX.
Conversion loss (X20)	150 MHz	dB		-5	-10
Adjacent harmonic suppression (X19)	150 MHz	dBc	-50	-55	
	150 MHz	dBc	-50	-55	
Second harmonic of output					
RF suppression (3 GHz reference)	150 MHz	dBc	-50	-55	
Input to output power sensitivity					
Input power change divided by output power change	@ +5 output	Ratio		10	
Spurious nonharmonic suppression	3 GHz	dBc		-55	
Output power, temperature dependence	@ +25°C	dB/Deg.		0.02	
OUTPUT PARAMETERS	CONDITION	UNITS	MIN.	TYP.	MAX.
RF frequency range	X20	GHz	2.85		3.15
RF VSWR		Ratio		1.7:1	2:1
RF power		dBm	+3	+5	
Noise power (not including source)		dBm/MHz		55	

SYS20M028032 TYPICAL TEST DATA

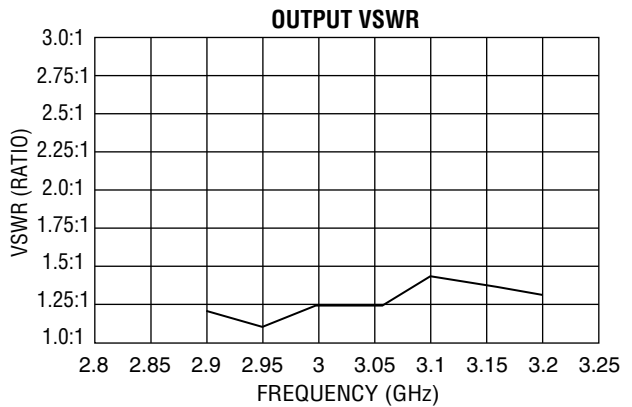
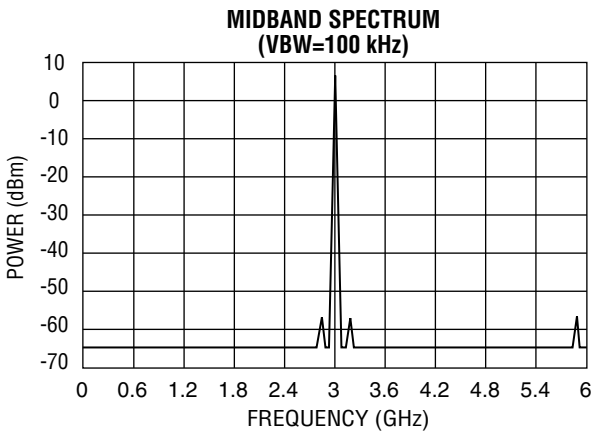
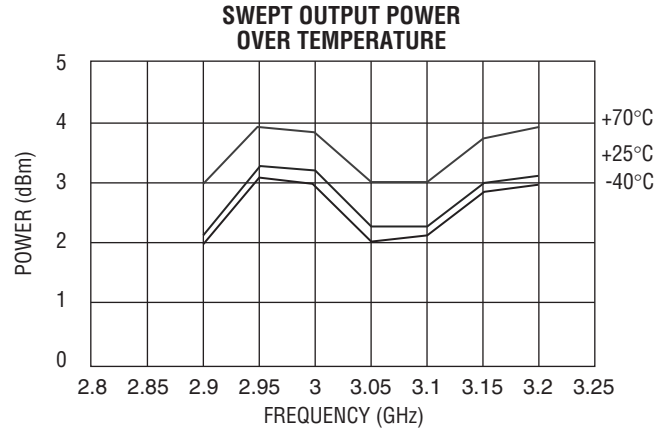
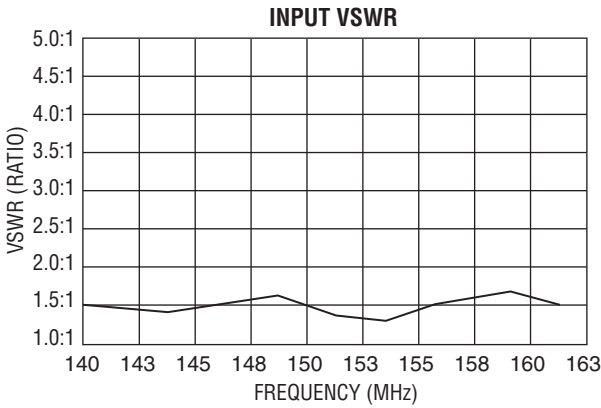

MAXIMUM RATINGS

Specification temperature..... +25°C
 Operating temperature -54 to +85°C
 Storage temperature -65 to +125°C

OUTLINE DRAWING

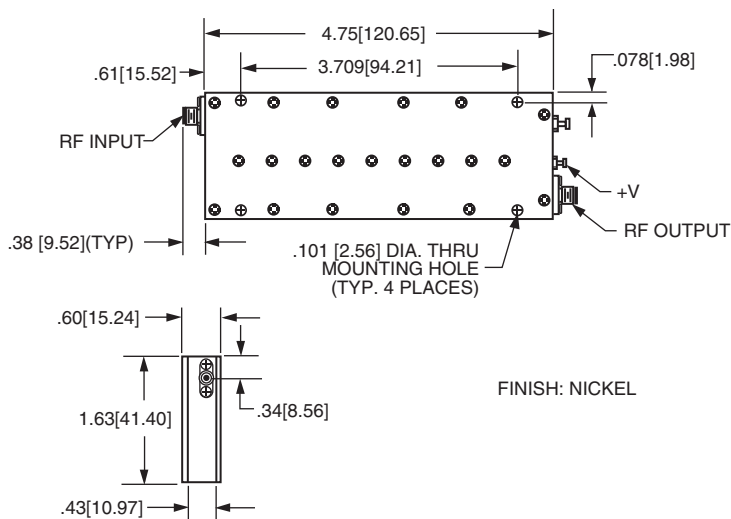

BLOCK DIAGRAM

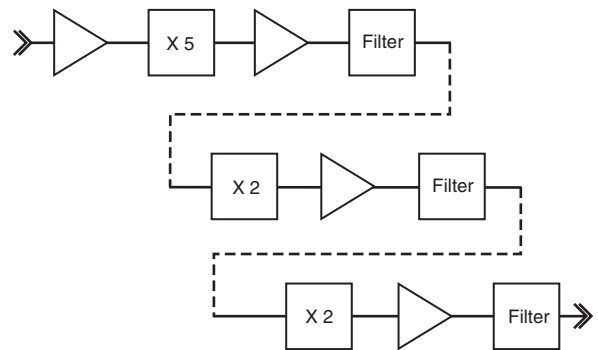

NOTE: All dimensions shown in brackets [] are in millimeters.

2 TO 18 GHz BIPOLAR/SRD/MESFET COMB GENERATOR

MODEL: EOM0218HW4

FEATURES

- RF output..... 2 to 18 GHz
- RF input 0.5 to 1.5 GHz
- High multiplication ratios
- Integrated input power amplifier
- Packaging..... Hermetically sealed



This unit is suitable for high-frequency LO generation using a lower frequency phase stable reference. The output spectrum is easily filtered, due to the large comb spacing (high input frequency and multiplication orders). In addition, an input low noise power amplifier is provided to allow seamless integration with a +10 dBm input source.

ELECTRICAL SPECIFICATIONS

INPUT PARAMETERS	CONDITION	UNITS	MIN.	TYP.	MAX.
RF frequency range		GHz	0.5		1.5
RF power range		dBm	+7	+13	
RF VSWR		Ratio	2:1		
TRANSFER CHARACTERISTICS	CONDITION	UNITS	MIN.	TYP.	MAX.
Conversion loss (X2)	1.5 GHz input	dB		17	20
(X4)		dB		18	21
(X9)		dB		24	27
(X12)		dB		33	36
OUTPUT PARAMETERS	CONDITION	UNITS	MIN.	TYP.	MAX.
RF frequency range		GHz	2		18
RF VSWR		Ratio	2:1		

EOM0218HW4 TYPICAL TEST DATA

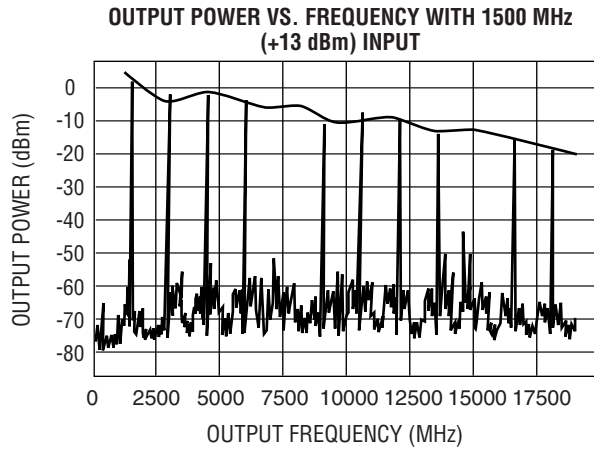

($P_{IN} = 13 \text{ dBm}$)
 ($F_{IN} = 1500 \text{ MHz}$)

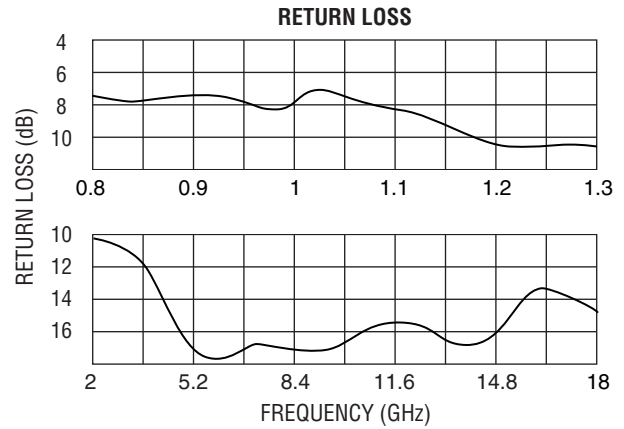

MAXIMUM RATINGS

Specification temperature..... +25°C
 Operating temperature -54 to +85°C
 Storage temperature -65 to +125°C

OUTLINE DRAWING

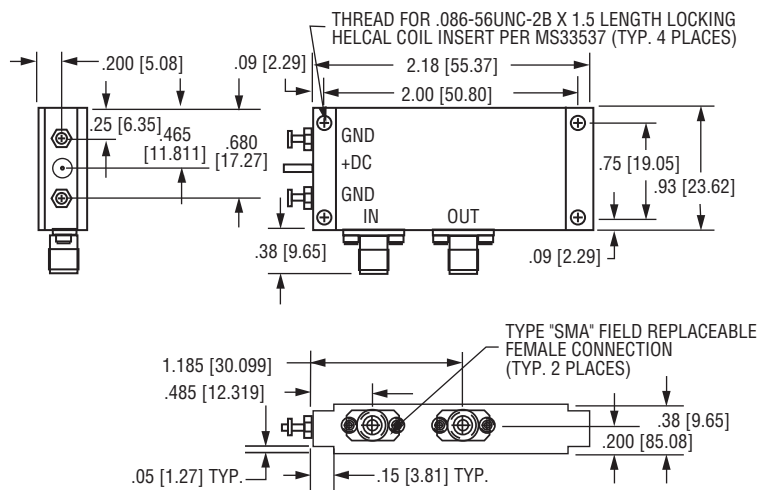

BLOCK DIAGRAM

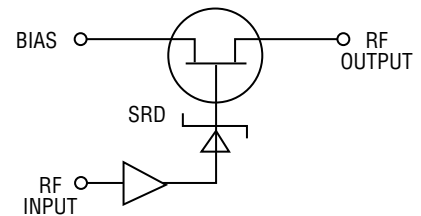

NOTE: All dimensions shown in brackets [] are in millimeters.

ACTIVE MULTIPLIER ASSEMBLIES

MAX4M050055-14P 5 TO 5.5 GHz, MID OUTPUT LEVEL ELECTRICAL SPECIFICATIONS

Input frequency	1.25 – 1.375 GHz minimum
Input power	+10 dBm minimum
Input VSWR	2:1 typical
Output frequency	5 – 5.5 GHz minimum
Output power	+14 dBm minimum
Output power flatness (at +25°C)	±1.5 dB maximum
Output spurious rejection	-60 dBc typical
Output harmonic rejection	-15 dBc typical
Rejection of input harmonics	-50 dBc typical
Output VSWR	2:1 typical
DC power	+15 VDC, 250 mA

SWEPT OUTPUT POWER

(with +10 dBm input)

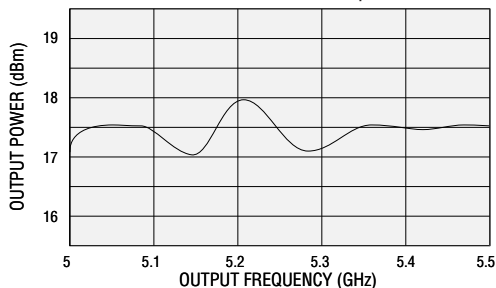

X 4 ACTIVE MULTIPLIER ASSEMBLIES

OPTIONS

- Input Power +5 to +20 dBm

FUNCTIONAL BLOCK DIAGRAM For units below 26 GHz

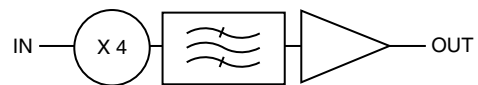

MAX4M062071 6.2 TO 7.1 GHz, MID OUTPUT LEVEL ELECTRICAL SPECIFICATIONS

Input frequency	1.55 – 1.78 GHz minimum
Input power	+10 dBm typical
Input VSWR	2:1 typical
Output frequency	6.2 – 7.1 GHz minimum
Output power	+10 dBm minimum
Output power flatness (at +25°C)	±2 dB maximum
Output spurious rejection	-65 dBc typical
Output harmonic rejection	-15 dBc typical
Rejection of input harmonics	-65 dBc typical
Output VSWR	1.5:1 typical
DC power	+15 VDC, 250 mA

SWEPT OUTPUT POWER

(with +10 dBm input)

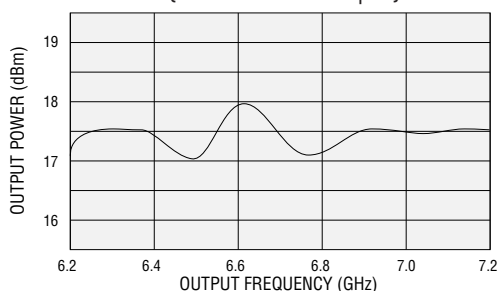

MAX4M400480 40 TO 48 GHz, MID OUTPUT LEVEL ELECTRICAL SPECIFICATIONS

Input frequency	10 – 12 GHz minimum
Input power	+10 dBm minimum
Output frequency	40 – 48 GHz minimum
Output power	+8 dBm minimum
Output power flatness (at +25°C)	±2 dB maximum
Output spurious rejection	-60 dBc typical
Rejection of input harmonics	-18 dBc typical
DC power	+15 VDC, 200 mA

SWEPT OUTPUT POWER

(with +10 dBm input)

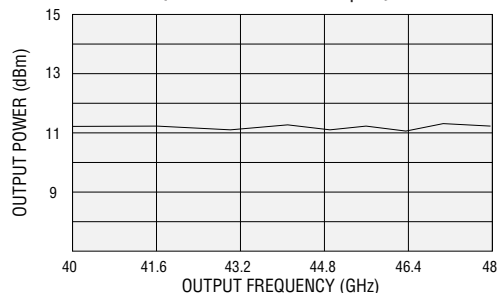

ACTIVE MULTIPLIER ASSEMBLIES (CONT.)

MAX4M127134 12.71 TO 13.28 GHz, MID OUTPUT LEVEL ELECTRICAL SPECIFICATIONS

Input frequency	3.1775 – 3.32 GHz minimum
Input power	+12 dBm typical
Input VSWR	2.5:1 typical
Output frequency	12.71 – 13.28 GHz minimum
Output power	+13 dBm typical
Output power flatness (at +25°C)	±1 dB maximum
Output spurious rejection	-65 dBc typical
Output harmonic rejection	-15 dBc typical
Rejection of input harmonics	-65 dBc typical
Output VSWR	1.5:1 typical
DC power	+5 VDC, 110 mA*

* -2.5 V required.

SWEPT OUTPUT POWER

(with +12 dBm input)

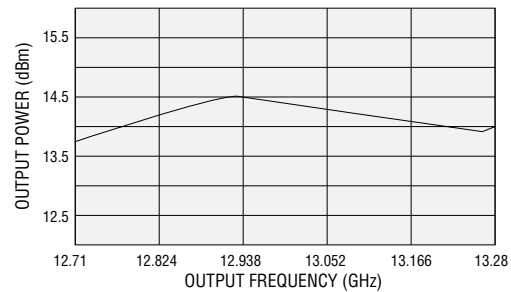

PASSIVE MULTIPLIERS - OUTLINE DRAWINGS

GENERAL NOTES

- All dimensions shown in brackets [] are in millimeters.
Tolerance as follows:
.xx = ± 0.01 [.xx = ± 0.25]
.xxx = ± 0.005 [.xxx = ± 0.13]
- Optional SMA, K or V type male. SMA type only, on multipliers below 26 GHz.

MX2A

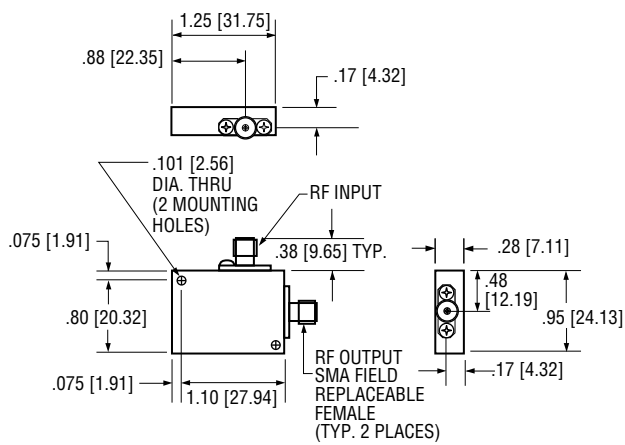

MX2B

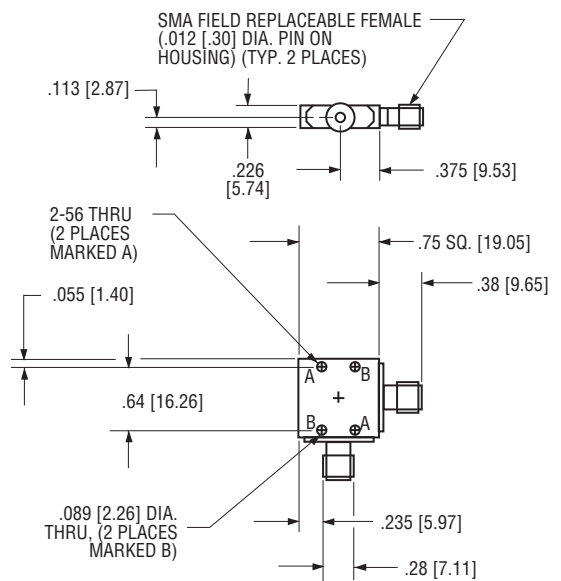

PASSIVE MULTIPLIERS - OUTLINE DRAWINGS (CONT.)

MX2C

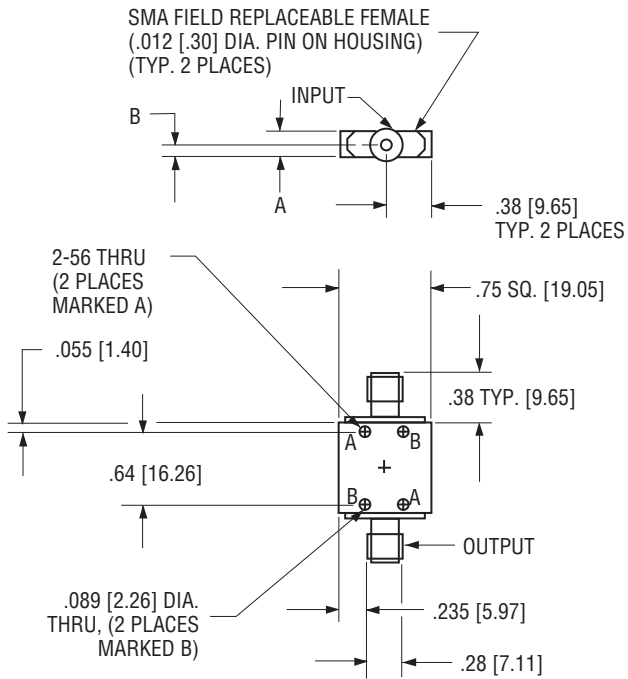

OUTLINE
DASH NO.

DIM A

DIM B

-1

.226 [5.74]

.121 [3.07]

MX2D

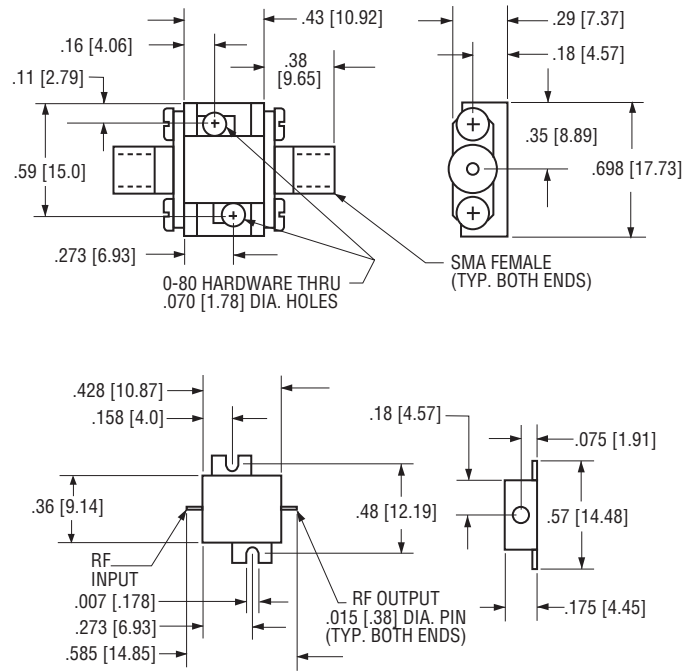

NOTE: Doubler may be readily used as is, or as a drop-in by removing the SMA connectors and mounting hardware as shown.

MX2E

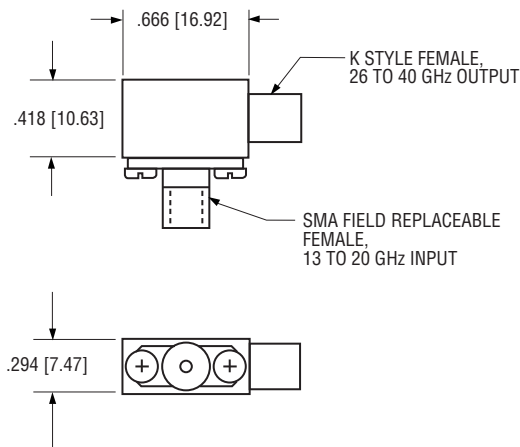

MXF

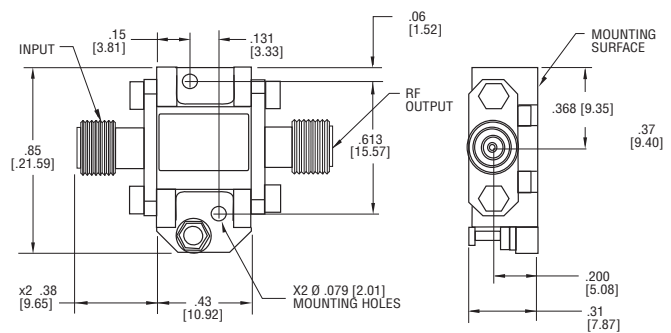

NOTE: Optional waveguide output available, please contact MITEQ.

ACTIVE MULTIPLIERS - OUTLINE DRAWINGS

GENERAL NOTES

- All dimensions shown in brackets [] are in millimeters.
Tolerance as follows:
.xx = ± 0.01 [.xx = ± 0.25]
.xxx = ± 0.005 [.xxx = ± 0.13]
- Optional SMA, K or V type male. SMA type only, on multipliers below 26 GHz.

MAX2A

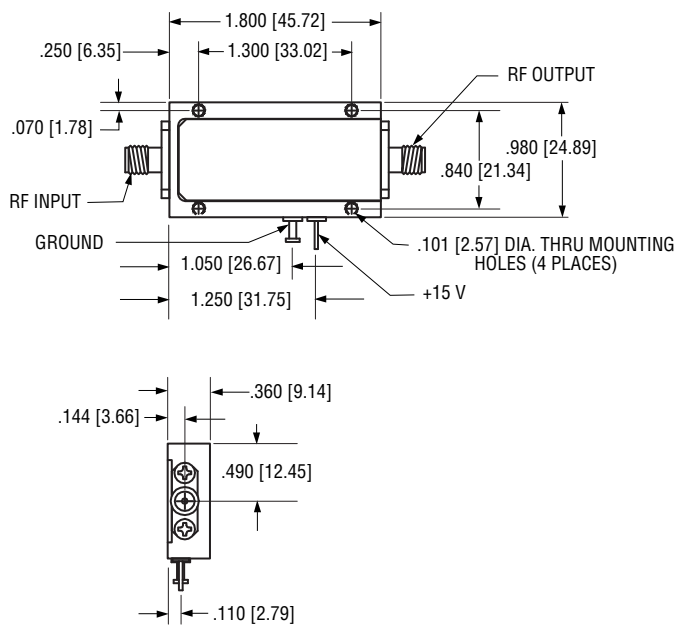

MAX2B

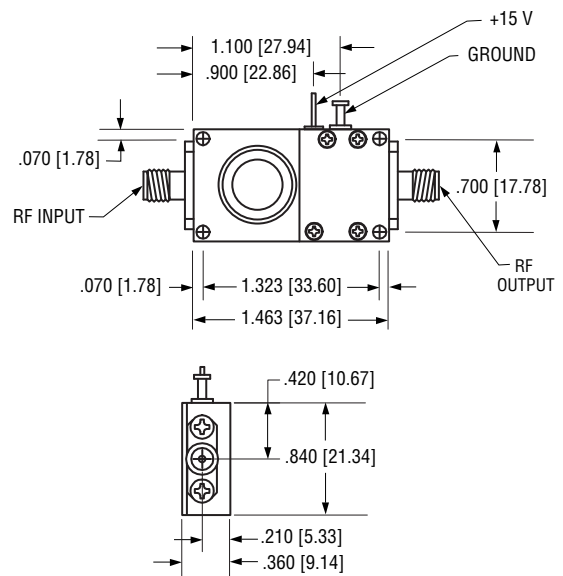

MAX2A2

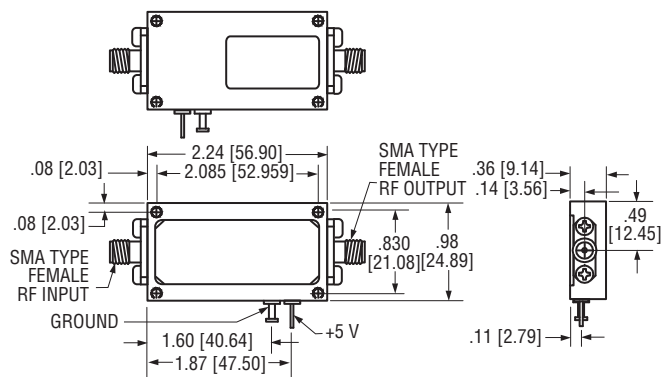

ACTIVE MULTIPLIERS - OUTLINE DRAWINGS (CONT.)

MAX2C

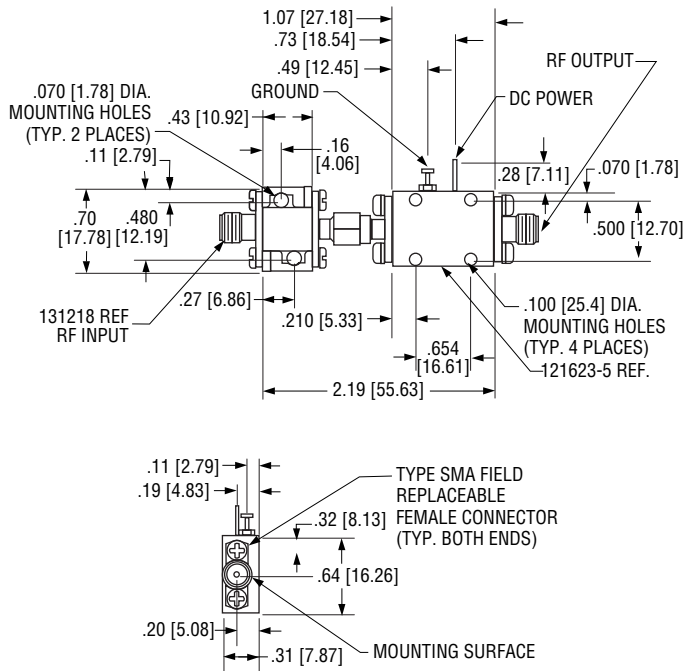

MAX2C2

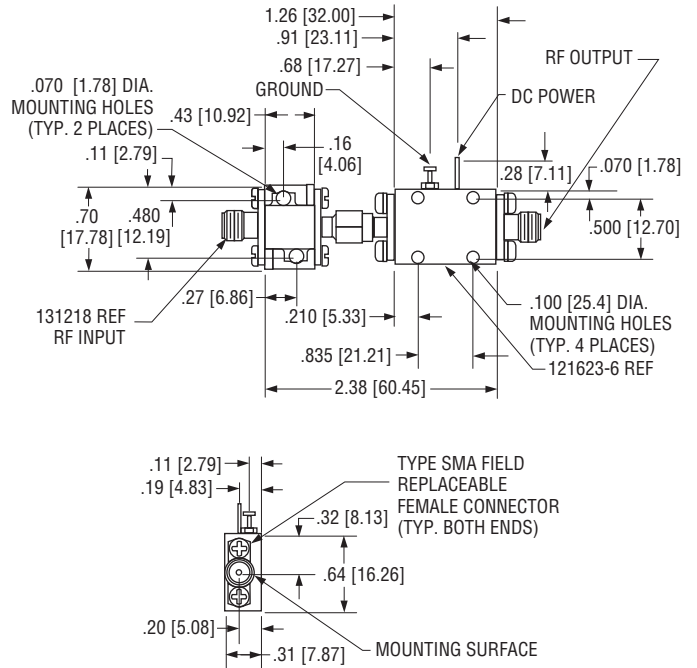

MAX2D

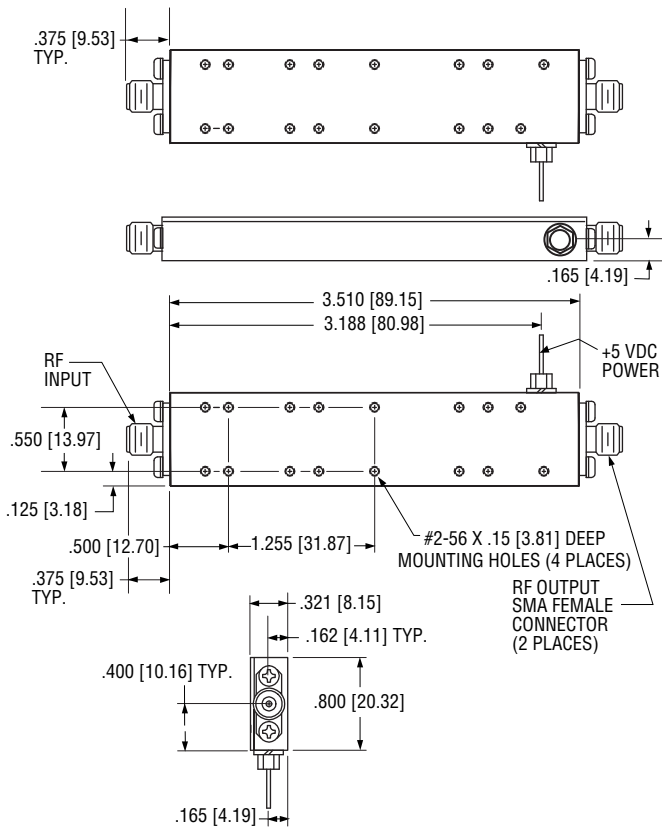

MAX2E

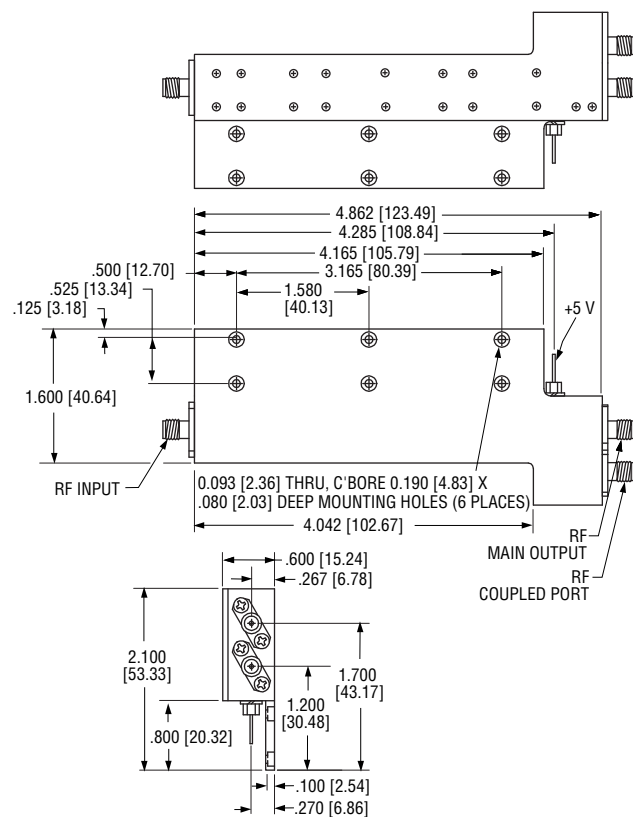

ACTIVE MULTIPLIERS – OUTLINE DRAWINGS (CONT.)

MAX2G

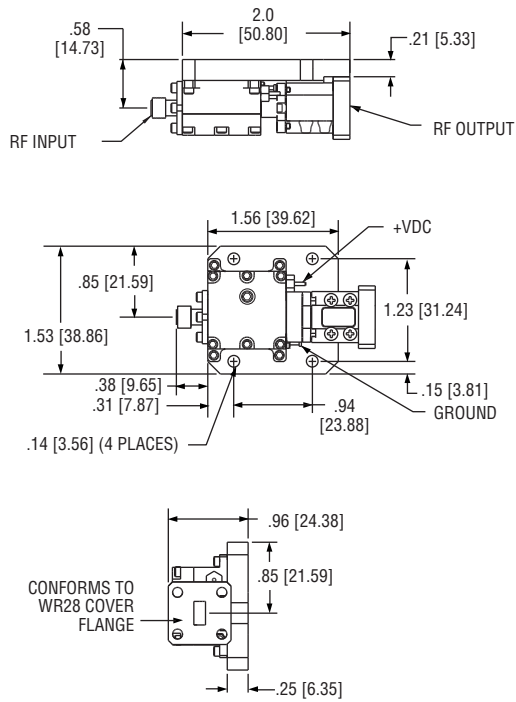

MAX2H

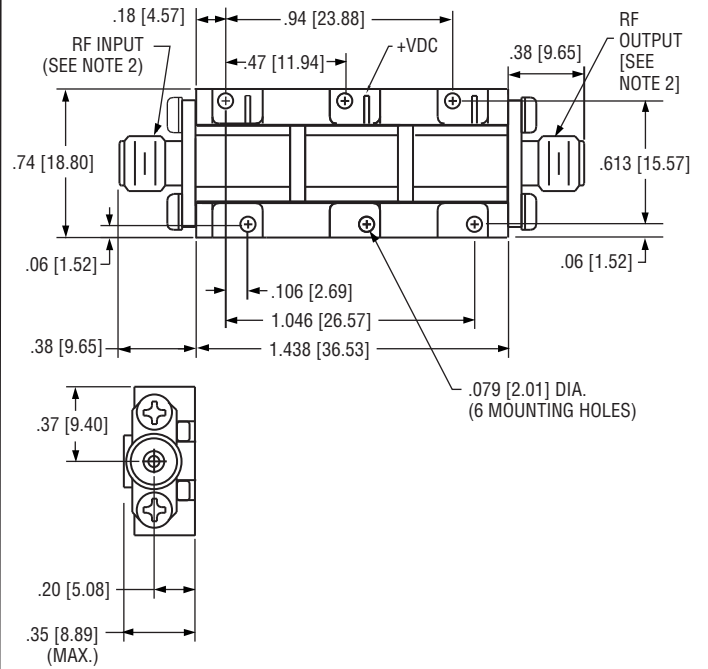

MAX2J

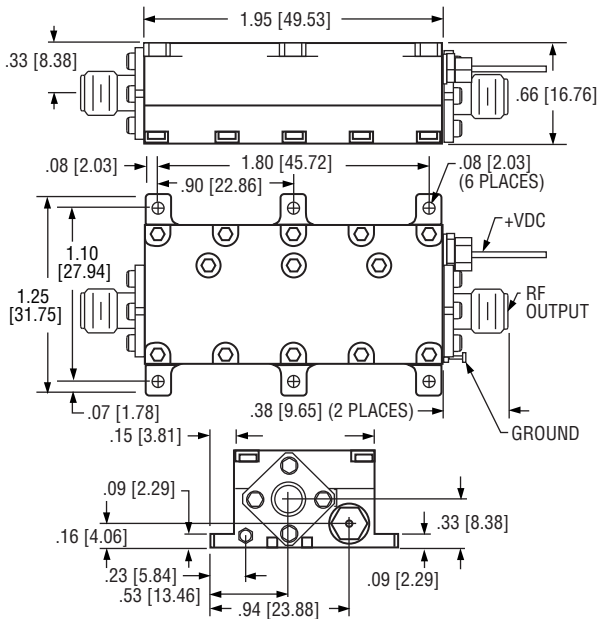

MAX2K

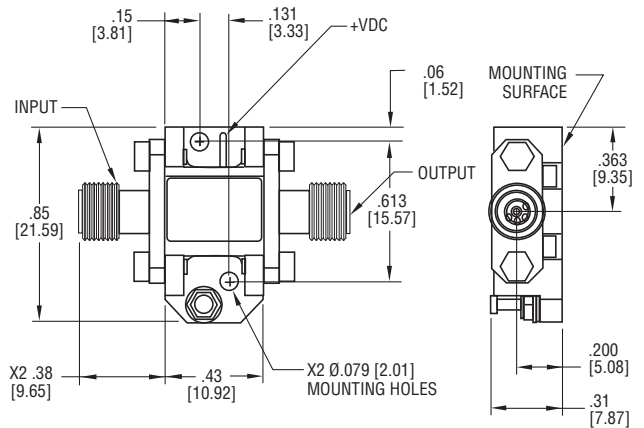

NOTE: Optional waveguide output available, please contact MITEQ.

ACTIVE MULTIPLIERS - OUTLINE DRAWINGS (CONT.)

MAX2L

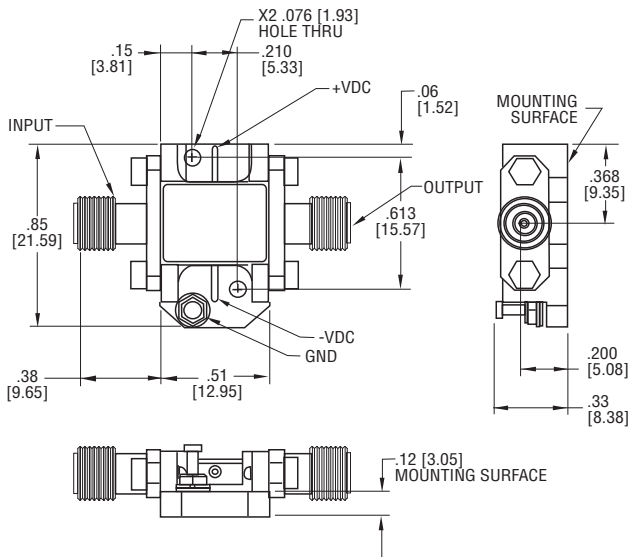

NOTE: Optional waveguide output available, please contact MITEQ.

MAX2M

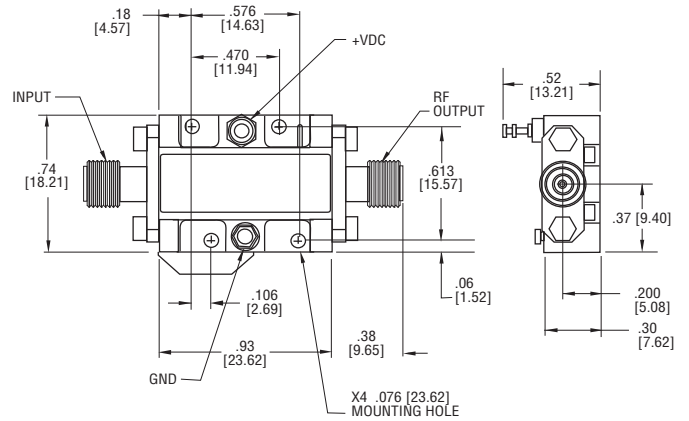

MAX2N

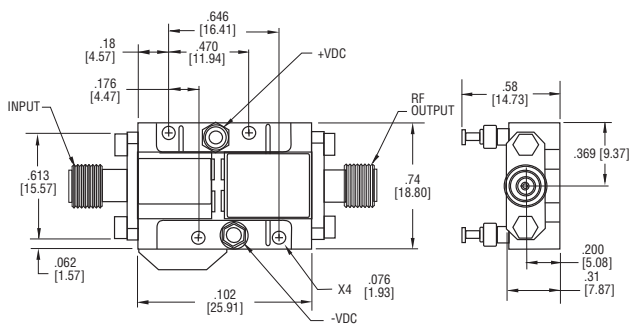

MAX3A

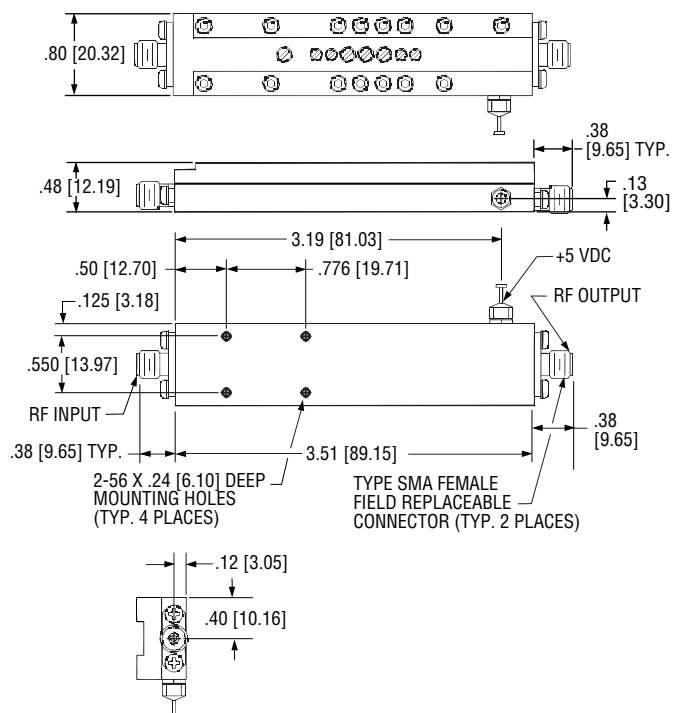

ACTIVE MULTIPLIERS - OUTLINE DRAWINGS (CONT.)

MAX4A

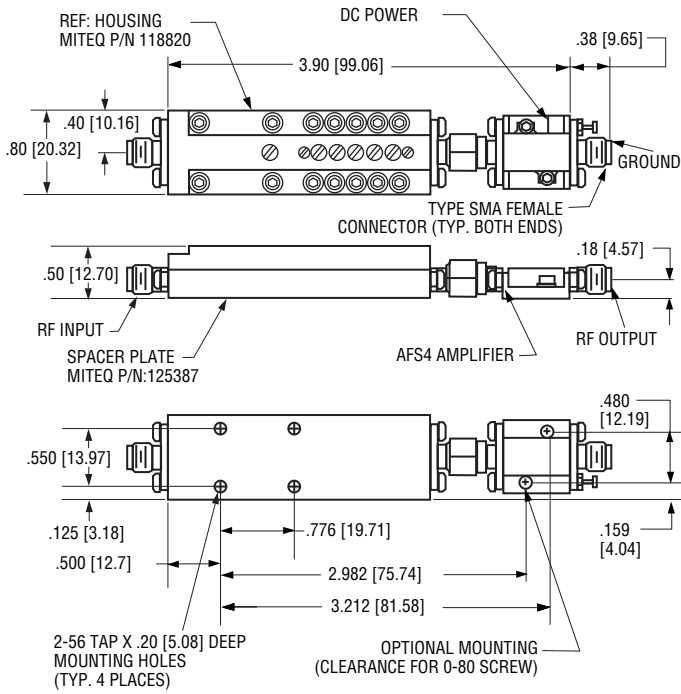

MAX4B

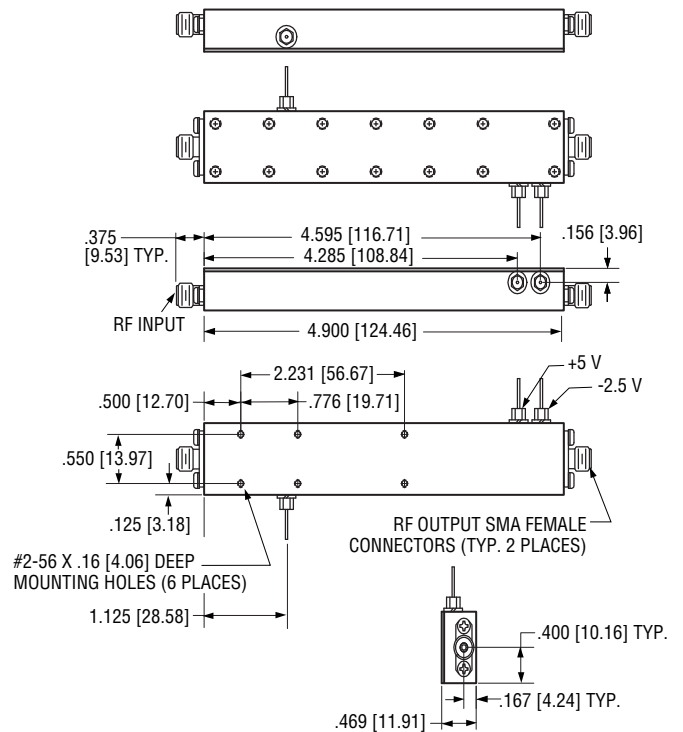

MAX4C

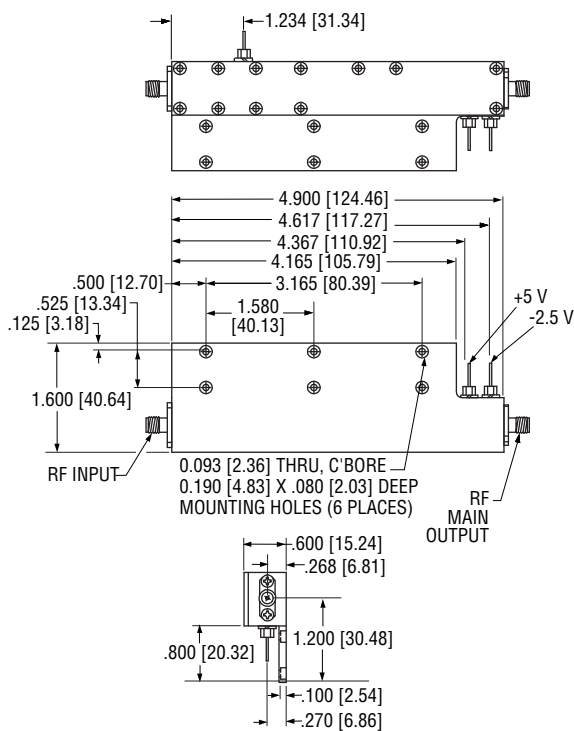

MAX4D

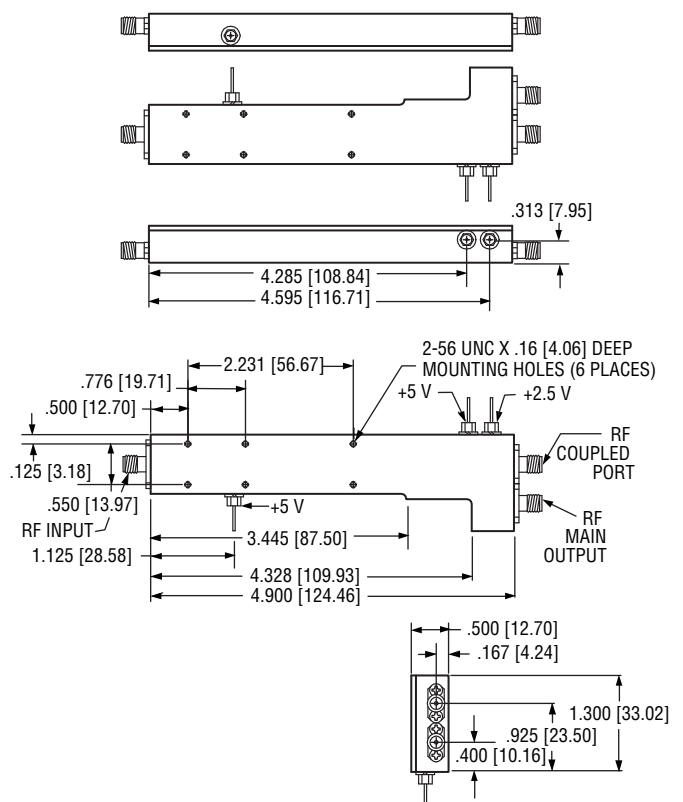

ACTIVE MULTIPLIERS - OUTLINE DRAWINGS (CONT.)

MAX4E

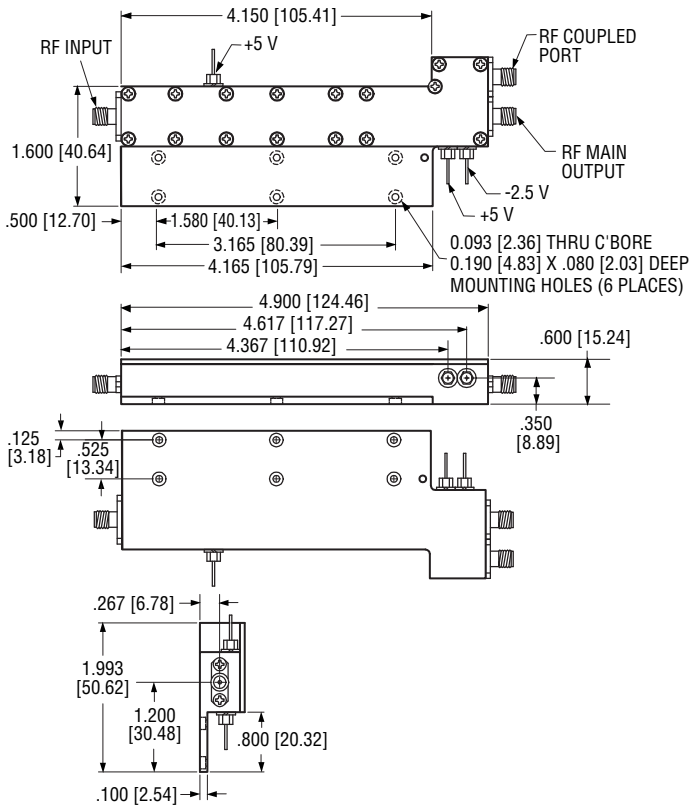

120373

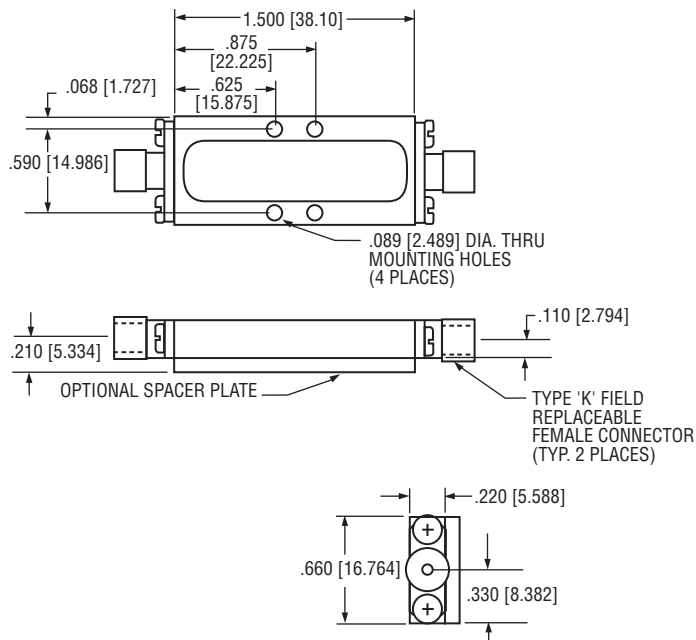

MAX5A

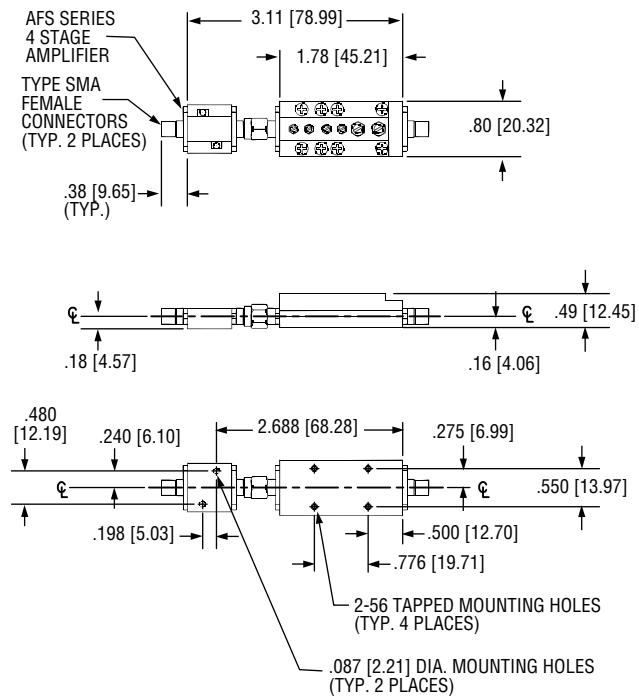

149228

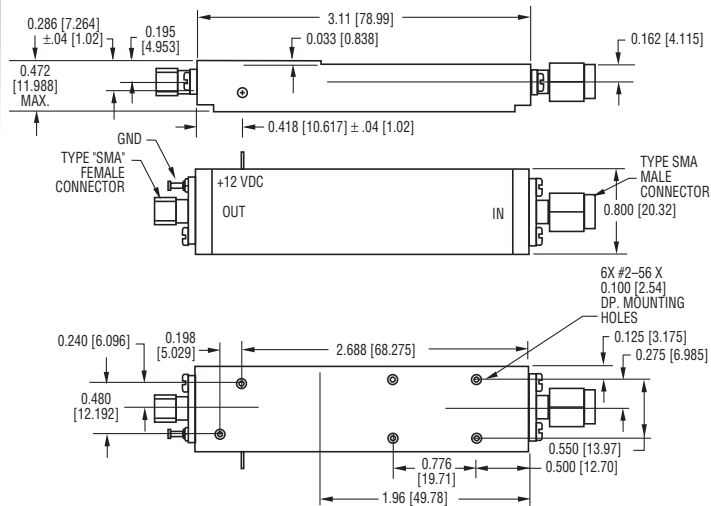

ACTIVE MULTIPLIERS - OUTLINE DRAWINGS (CONT.)

157345

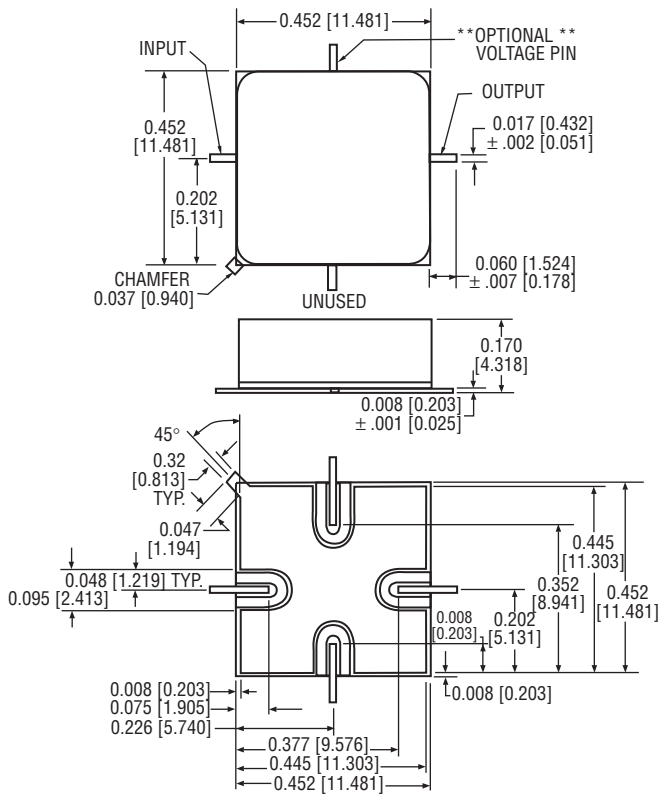

157637

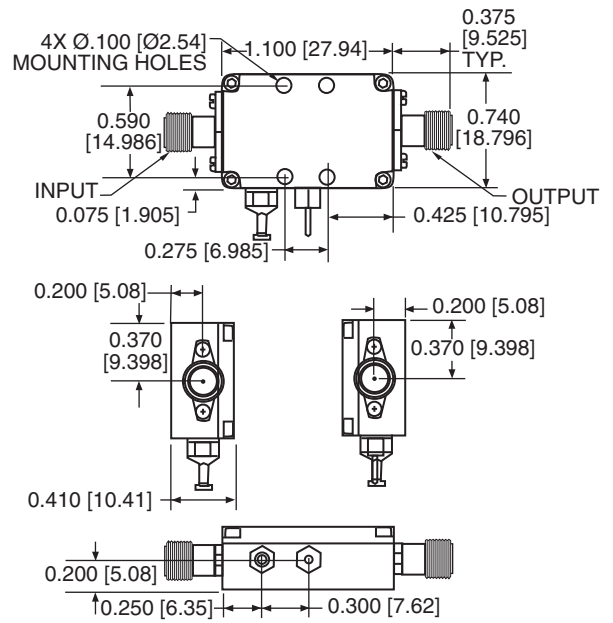

160057

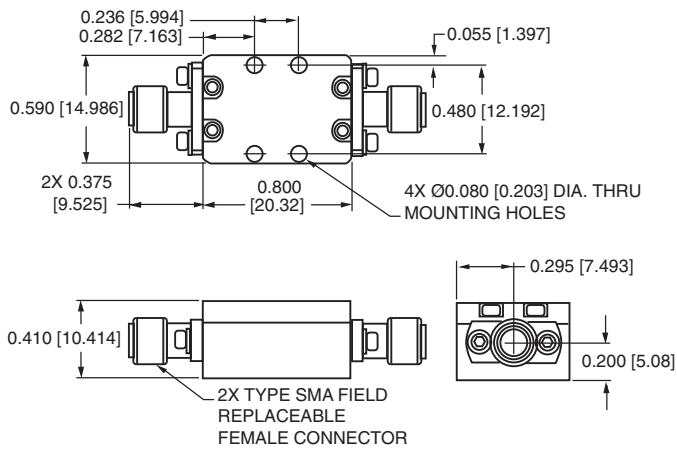

160212

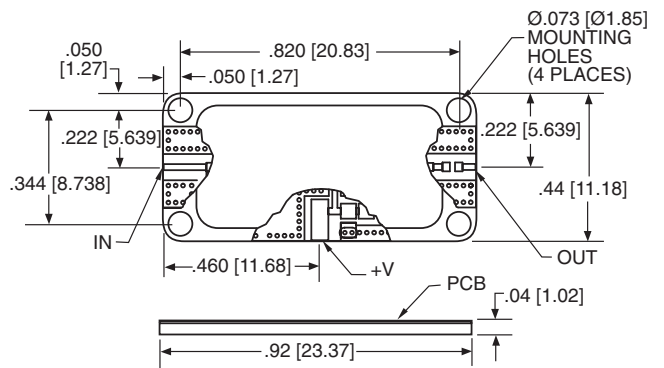

ACTIVE MULTIPLIERS - OUTLINE DRAWINGS (CONT.)

160833

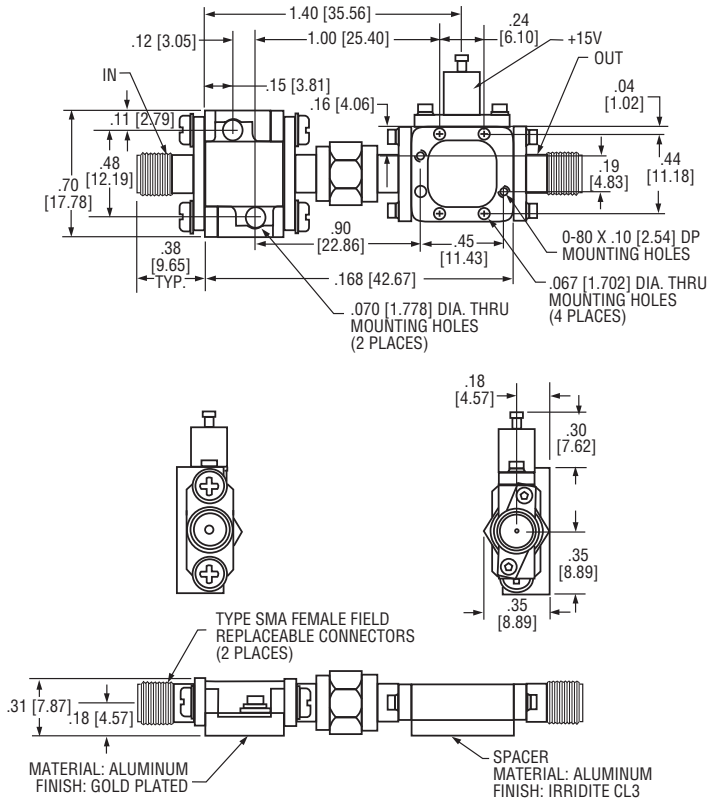

161565

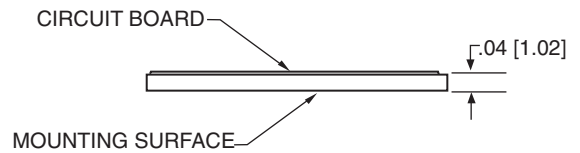
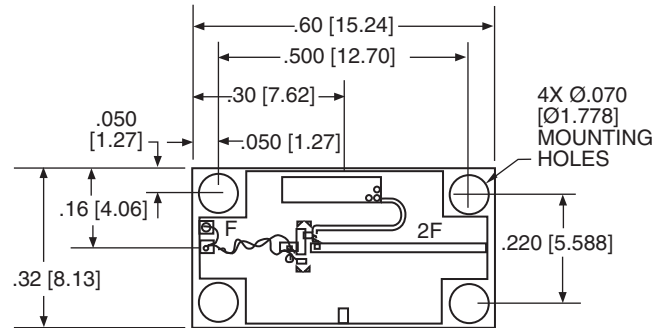

161566

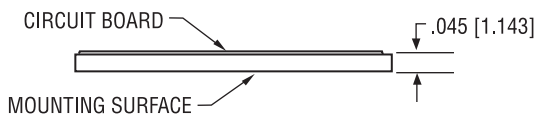
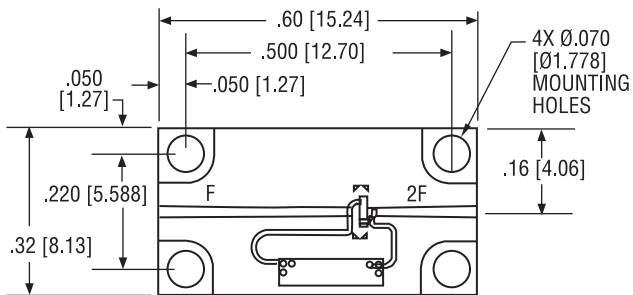

162011

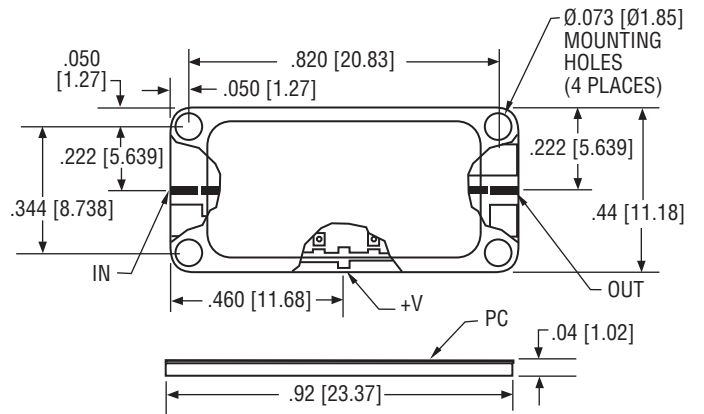

ACTIVE MULTIPLIERS - OUTLINE DRAWINGS (CONT.)

163124

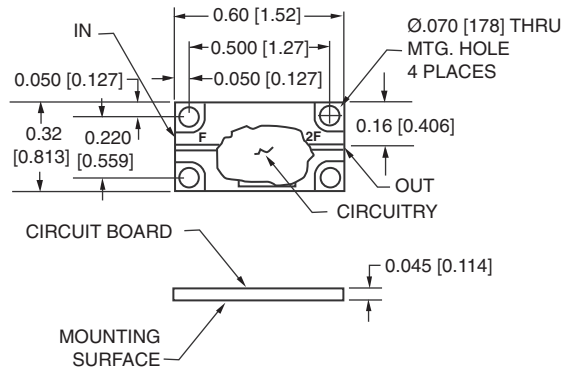

163640

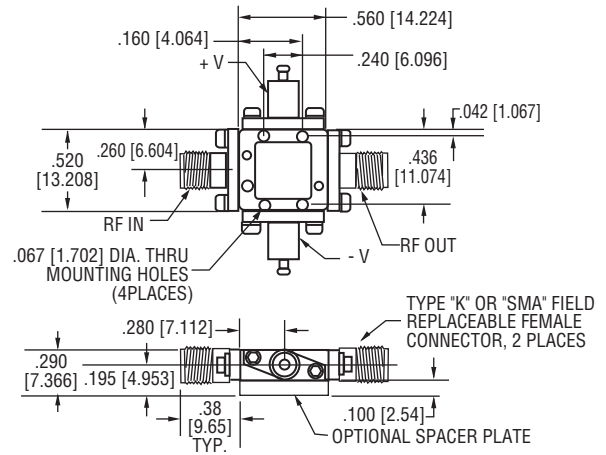

NOTES:

1. Unit's mounting surface shall be attached to a heatsink capable of dissipating the devices power consumption without exceeding the operating temperature limits.
2. Refer to the actual device specification sheet for bias requirements. Negative bias input voltage (v-) may not be included on certain models.
3. Unless noted on the specification sheet, when negative bias is required, do not power the unit with positive bias for more than one second without the negative bias being applied.



Questions and Answers about...

FREQUENCY MULTIPLIERS

Q1: What do I need a frequency multiplier for?

A1: In general, a frequency multiplier translates an input frequency range to an output one, the output one being a multiple of the input. This is useful when an output signal is really needed higher than an available input source can supply. It could cost quite a lot to buy a source at higher frequencies. A better cost approach would be to use a less costly one, and just multiply the signal.

Q2: What specifications are important for a multiplier, and which ones should be given the most consideration?

A2: On page 380, some general rules and typical values are presented. Some important insights can be found by considering the way or system in which the multiplier will be used. It could be useful to examine the desired system specifications, in particular spurious rejection.

Q3: I need a custom multiplier, not shown in the catalog, what should be done next?

A3: Try to locate a somewhat similar product and identify the differences. Contact MITEQ for additional technical support.

Q4: I have a military and/or space multiplier requirement, and I cannot find any indication that MITEQ has produced such products. Is this a problem?

A4: MITEQ regularly gets such multiplier requirements. They are reviewed, and as such these custom multipliers are specific to a unique situation, and are not shown in our catalog.

Q5: I need a multiplier system, which includes non-multiplier type structures. Can MITEQ manufacture these type of systems and what sort of quantities, can MITEQ handle?

A5: A considerable amount of MITEQ's multiplier business includes small quantity custom products. Depending on future order potential and how much your budget can allow, all sorts of possibilities exist. Some of MITEQ's largest multiplier orders fit in this category.

Q6: What system precautions are important when specifying multiplier component specifications?

A6: One or more multipliers are often employed to upconvert a lower frequency stable reference oscillator into the system microwave operating frequency. Since active gain and filter stages are often necessary, one must insure that all multiplier output harmonics of the input reference frequency are adequately suppressed and the output power to noise floor ratio is compatible with the system phase noise specification. Since one or more gain stages of an active multiplier are saturated, AM noise is not usually a consideration.

Q7: What types of frequency multiplier circuits are available?**A7:** In order of increasing complexity:

- Single or single antiparallel pair Schottky diodes
- Single-, double- or triple-balanced Schottky diodes with baluns
- Active amplifiers and/or MMICS
- SRD (step-recovery diode) circuits
- Varactor diodes, resistive loaded
- Varactor diodes, regenerative

Q8: What precaution is necessary when specifying a multiplier to be followed by an active (and saturated) gain stage?

A8: If the amplifier is high gain with large bandwidth and saturates at +10 dBm, then the highest level multiplier output will produce +10 dBm output. However, if the fifth harmonic is desired from the multiplier but the third is more efficient by 6 dB, then the 5X output will be suppressed by the gain difference. This can be avoided by filtering the third harmonic or utilizing a multiplier with tuned baluns (MITEQ type FEM, FOM).

Q9: Can ordinary double- or triple-balanced mixers be used as multipliers?

A9: Yes, particularly as doublers, when the RF and LO are the same input frequency and the SUM (2RF) is extracted from the highest frequency port of the mixer. The total input power should be sufficient to turn on the diodes. The MITEQ 4 to 40 GHz triple-balanced mixer is available with an internal power splitter to direct the input energy to the LO and IF port (2 to 20 GHz) and recover the 4 to 40 GHz output at the RF port.

Q10: When is it wise to use a Schottky diode multiplier and when is an SRD or varactor type more suitable?

A10: Schottky diode multipliers are lowest cost and require the least input power (+10 dBm). Output noise is at room temperature (KTBW). The resulting current waveforms, however, have a high duty cycle (i.e., square wave = 50%) and therefore, higher multiplier harmonics above the fifth decay quickly. Step-recovery diodes have impulsive waveforms with comb-like output spectrums. The input circuit is more complex requiring a compromise between bandwidth and efficient coupling to the low diode series resistance. The required input power is a function of the SRD capacitance and quickly rises with frequency (+20 dBm typical at 1 GHz). The hyper abrupt varactor diode (indistinguishable at high frequencies from the SRD) yields the highest output powers and efficiency, provided that unwanted sidebands are reactively terminated. MITEQ has successfully made efficient frequency doublers and prescalers (halvers) at 10 and 20 GHz.